

Part Number: PTS21-52085

NOTE: Part number of this accessory may not be the same as the part number shown.

Light Guide Kit Contents

Item #	Quantity Reqd.	Description
1	1	Controller Board, 4 color programmed w/ Bracket
2	1	RGB, LED Engine wire harness
3	2	14mm Light Rod, 8" Length
4	1	Push button switch, momentary Type
5	1	RGB Cup holder wire harness
6	1	Power harness with fuse
7	1	Installation hardware kit
8	1	Installation instructions

Hardware Kit Contents

Item #	Quantity Reqd.	Description
1	2	Foam pad with adhesive (38.1 x 38.1 x 4.75mm)
2	4	1/8" Rivets
3	4	1/8" Rivet washers
4	4	Catamounts
5	12	Wire ties (177.8mm)
6	1	Cup Lens Kit
7	1	Push button switch mounting hardware
8	1	"Illumination" switch bezel
9	1	Switch installation tool
10	2	T-taps

Additional Items Required For Installation

Item #	Quantity Reqd.	Description

Conflicts

None

Recommended Tools

Personal & Vehicle Protection	Notes
Safety Glasses	
Safety Gloves	Optional
Vehicle Protection	Blankets, Part Boxes, Masking Tape
Special Tools	Notes
Switch installation tool	In hardware kit
0-50 in/lbs Torque Wrench	For Battery Terminals
Paper drill templates	See Appendix 1
Drill templates	PPO ONLY. IADS (xD-08-034)
Installation Tools	Notes
Nylon Panel Removal Tool	
Ratchet	
Socket	10 mm

Wire Cutters	
Phillips screwdriver	
Drill motor	
1/2" Drill bit	Uni-bit or step drill rec.
5/16" Drill bit	
1/8" Drill bit	
Drill stop	
Center punch	
Deburring tool	
Non-scratch wiping cloth	
Scissors	
Pliers	
Rivet Gun	
Socket extension	6 inch

Special Chemicals	Notes
All Purpose Cleaner	VDC approved, mild water based, solvent free all purpose cleaner.





General Applicability

2008 SCION - xD

Recommended Sequence of Application

Item #	Accessory
1	Navigation system
2	V5 Security – RS3200 +
3	V4 RES
4	Illuminated Door Sills
5	Audio
6	Satellite Radio
7	Interior Light Kit

Legend

	STOP: Damage to the vehicle may occur. Do not proceed until process has been complied with.
	OPERATOR SAFETY: Use caution to avoid risk of injury.
	CAUTION: A process that must be carefully observed in order to reduce the risk of damage to the accessory/vehicle and to ensure a quality installation.
	TOOLS & EQUIPMENT: Used in Figures calls out the specific tools and equipment recommended for this process.

Care must be taken when installing this accessory to ensure damage does not occur to the vehicle. The installation of this accessory should follow approved guidelines to ensure a quality installation.

These guidelines can be found in the "Accessory Installation Practices" document.

This document covers such items as:-

- Vehicle Protection (use of covers and blankets, cleaning chemicals, etc.).
- Safety (eye protection, rechecking torque procedure, etc.).
- Vehicle Disassembly/Reassembly (panel removal, part storage, etc.).
- Electrical Component Disassembly/Reassembly (battery disconnection, connector removal, etc.).

Please see your Toyota dealer for a copy of this document.

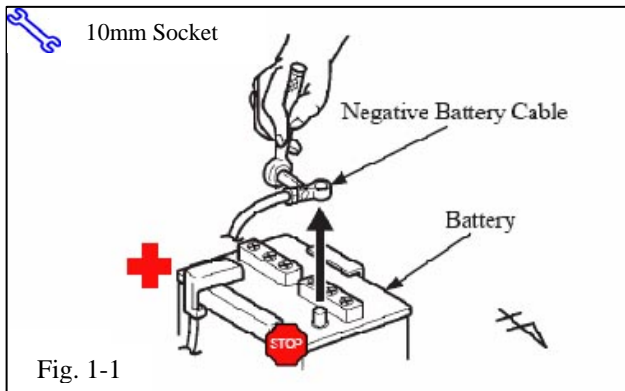

1. Vehicle Disassembly

(a) Remove the negative battery cable. (Fig. 1-1)



(1) Do not touch the positive terminal with any tool when removing cable.

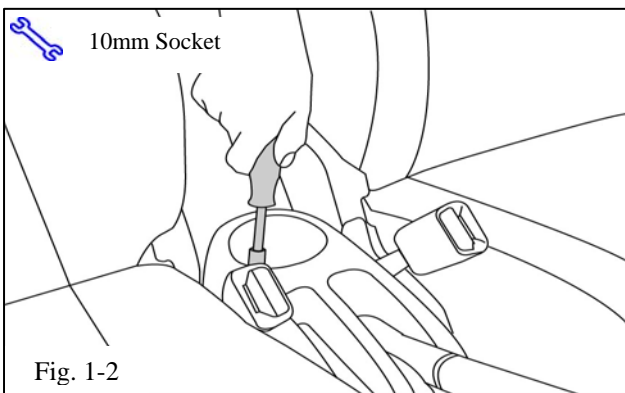

(b) Use a 10mm socket to remove the bolt in the rear console cup holder. (Fig. 1-2)

(c) Remove shift knob.

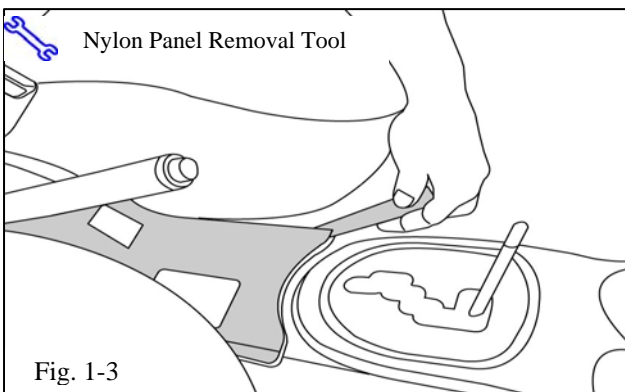

(d) Use panel safe tool to remove switch panel assembly. (Fig. 1-3)

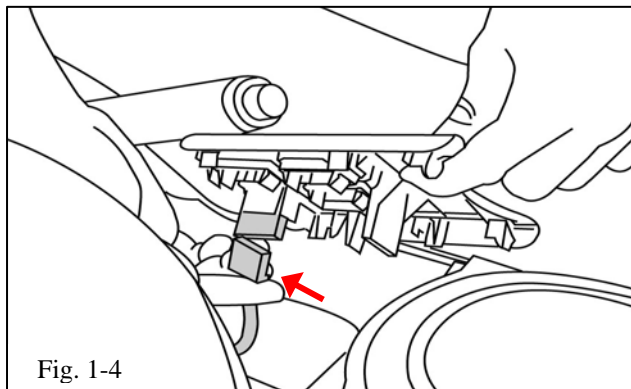

(e) Disconnect any connectors connected to the switch panel. (Fig. 1-4)

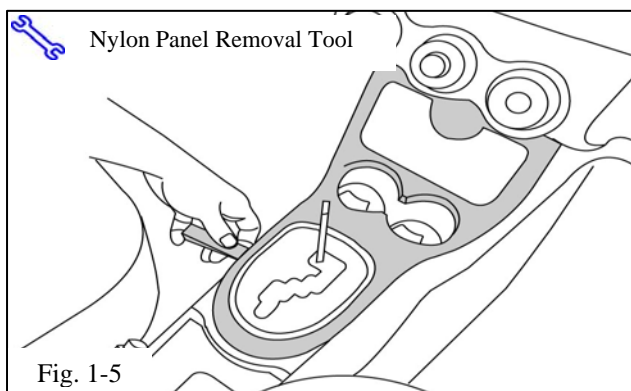

(f) Use panel safe tool and remove console trim piece. (Fig. 1-5)

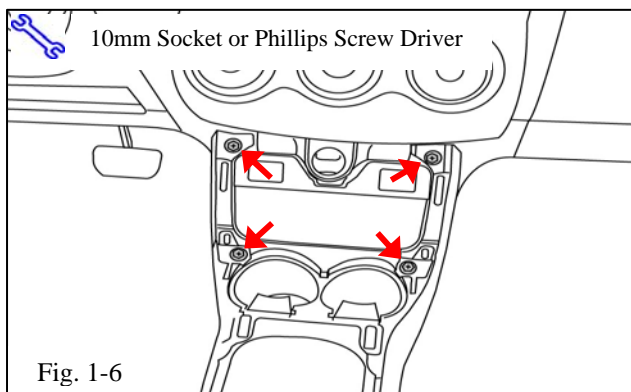

(g) Use a 10mm socket or Phillips screw driver and remove the four mounting bolts. (Fig. 1-6)

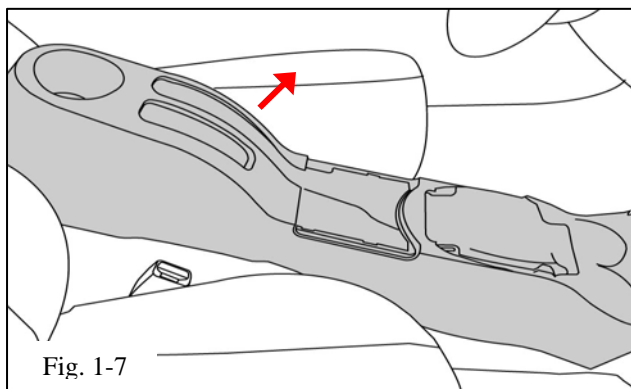

(h) Remove the console from interior of vehicle. (Fig. 1-7)

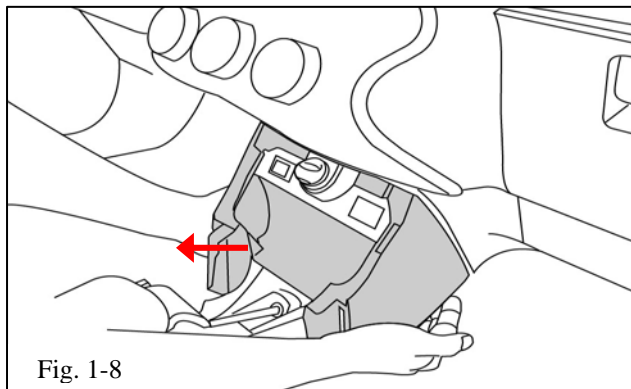

(i) Remove the front console piece. (Fig 1-8)

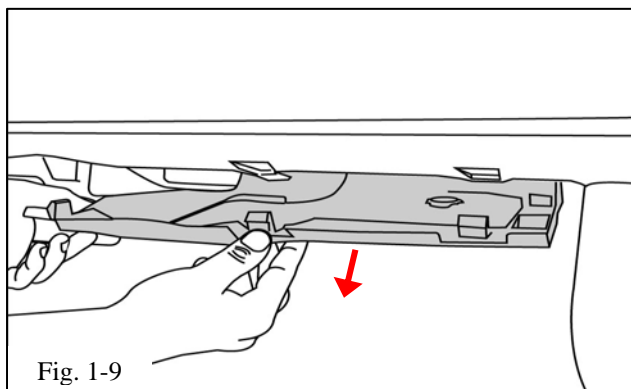

(j) Remove the passenger side lower under cover located below the glove box. (Fig. 1-9)

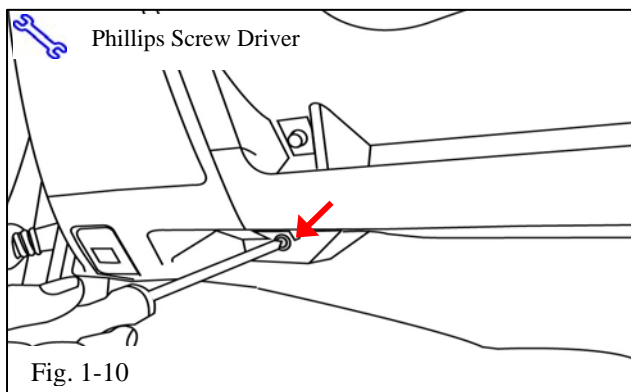

(k) Use a Phillips screw driver to remove the two mounting screws that secure the driver side lower under cover. (Fig. 1-10)

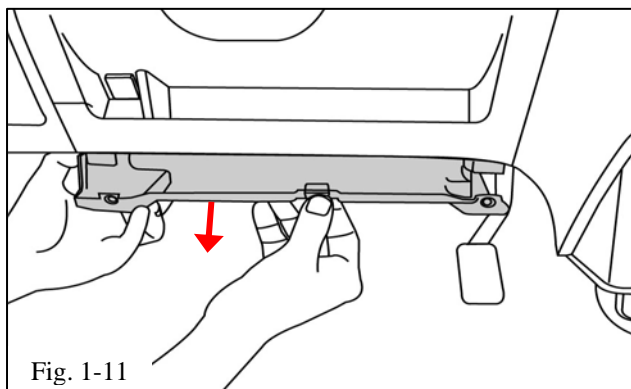

(l) Remove the driver side lower under cover. (Fig. 1-11)

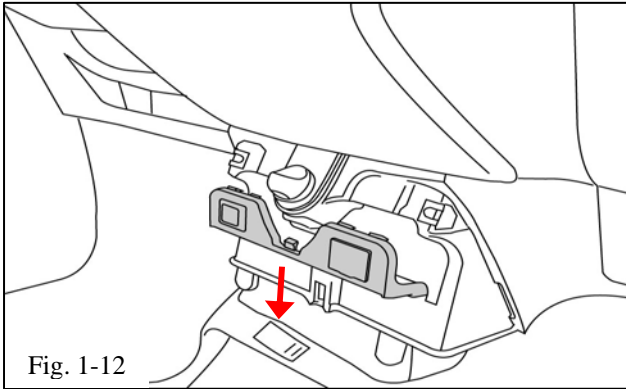

- (m) Lower the “Aux” and “Ipod” panel assembly. (Fig. 1-12)

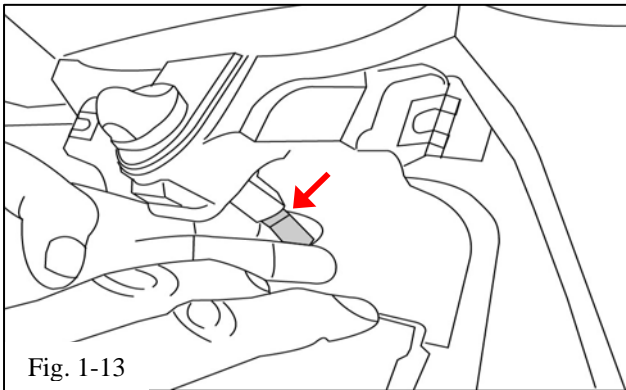

- (n) Disconnect the power outlet connector at the rear of power outlet socket. (Fig. 1-13)

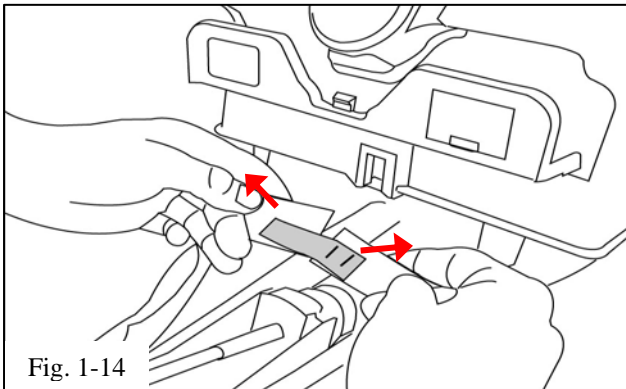

- (o) Separate the Velcro strap holding the carpet pieces together. (Fig. 1-14)

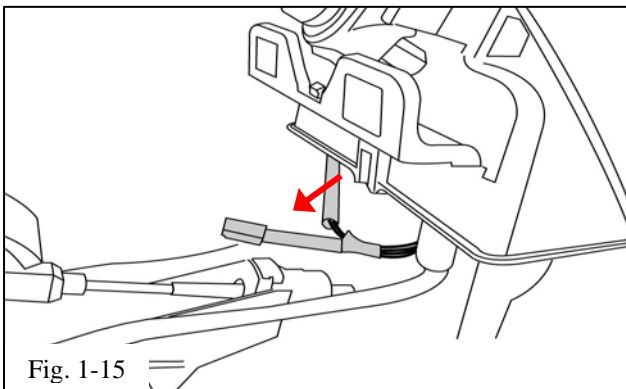

- (p) Bring the power outlet harness in front of the lower center console. (Fig. 1-15)

FOR DIO ONLY:

- (q) Cut out paper drill templates.

- (1) Check the two inch reference on the paper templates located at the end of the installation instructions for the correct scale.

- (2) Using scissors, cut out the paper templates.

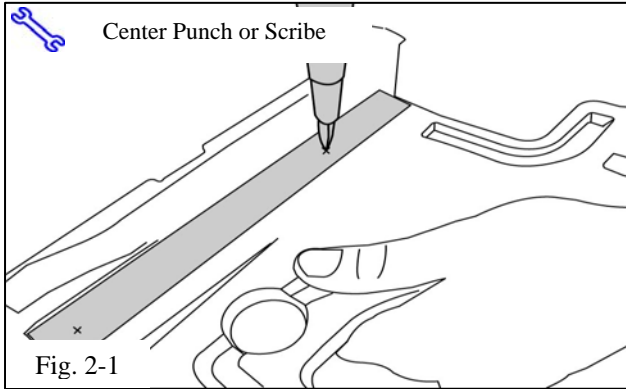

2. Installation of the Driver's Side Light Rod.

- (a) Align the Driver's side template to the bottom side of the driver side under cover.
 - (1) Punch or scribe a mark for the mounting holes to be drilled.
 - (2) Do not use the template to drill the holes. (Fig. 2-1)

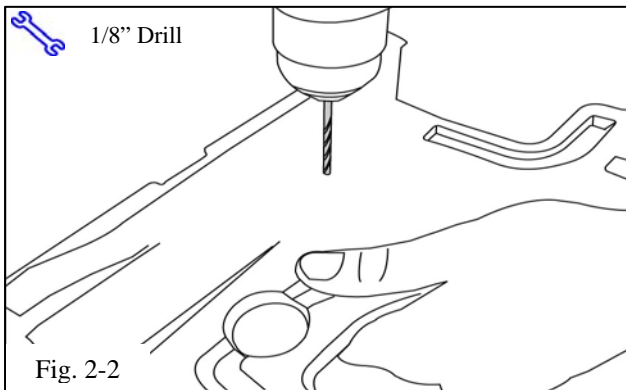

- (b) Drill the mounting holes using a 1/8" drill bit. Deburr holes. (Fig. 2-2)

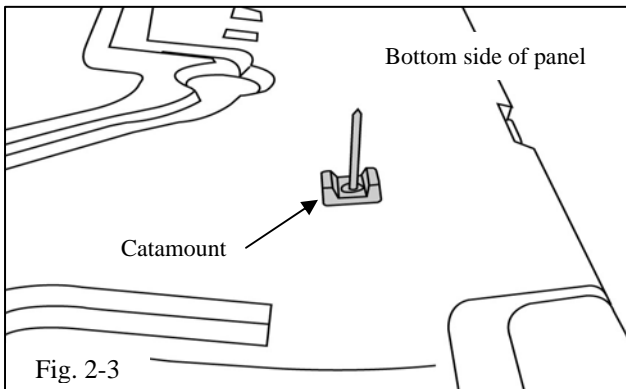

- (c) Insert rivets into catamounts and place into the holes drilled on the bottom side of the under cover. (Fig. 2-3)

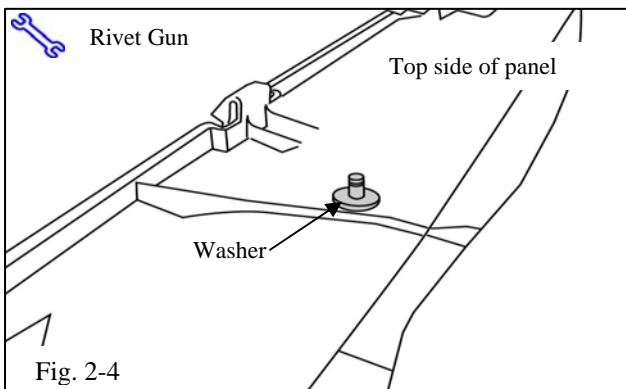

- (d) Install a rivet washer onto each of the rivets on the top side of the under cover and install the rivets using a rivet gun. (Fig. 2-4)

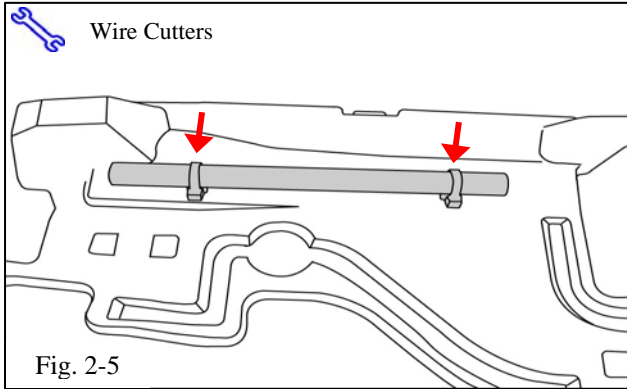

(e) Install the light guide onto the cover using two 7" wire ties. (Fig. 2-5)



(1) Reflector end of the light guide should be toward the outside of vehicle.



(2) Light guide should be oriented with white reflector at the top.

(3) Trim excess wire tie.

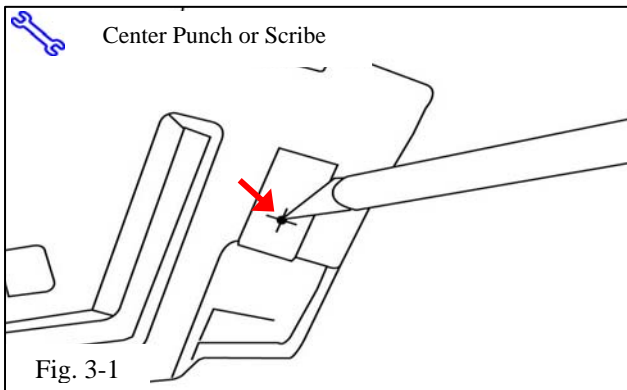

3. Installation of the Passenger Side Light Rod.

(a) Remove the felt cover from the backside of passenger under cover.

(b) Use template to mark the bottom side of the under cover using a punch or scribe as shown. (Fig. 3-1) (Fig. 3-2)

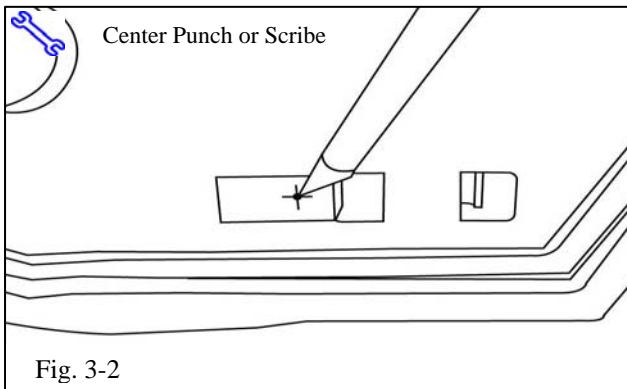

(c) Use a 1/8" drill bit and drill the holes for the mounting of the rivets. (Fig. 3-3)

(d) Insert rivets into catamount and place into the holes drilled on the bottom side of the cover.

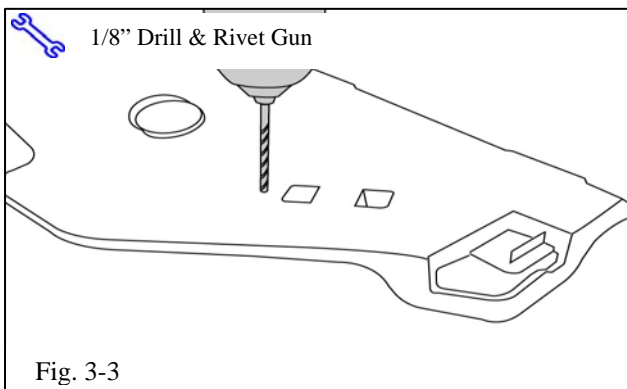

(e) Install rivet washers onto rivets on the top side of the cover and install using a rivet gun.

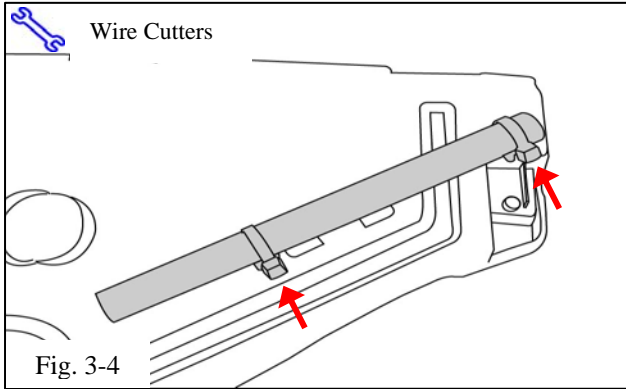

(f) Install the light guide onto the cover using two 7" wire ties. (Fig. 3-4)



(1) Reflector end of the light guide should be toward the outside of vehicle.



(2) Light guide should be oriented with white reflector at the top.

(3) Trim excess wire tie.

(g) Reinstall Felt Cover.

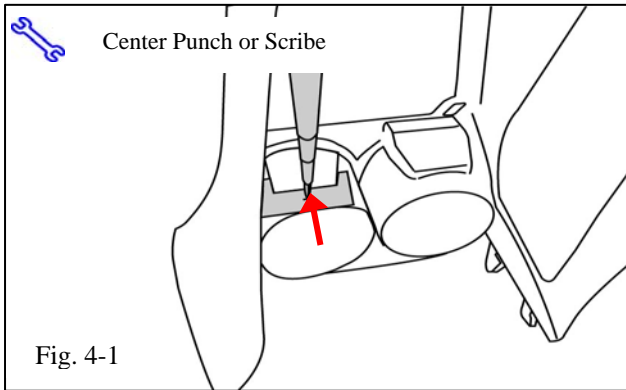

4. Installation of the Cup holder harness to center console.

(a) Align cup holder template. Mark the hole for each cup holder location using a punch or scribe. (Fig. 4-1)

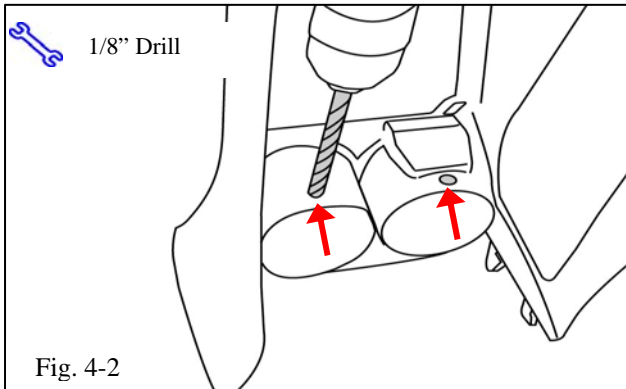

(b) Drill pilot holes with a 1/8" drill bit. Drill final holes with a 5/16" drill bit. Deburr Holes. (Fig. 4-2)

(c) Remove tape liner from the threads of the cup holder lenses. From inside the cup holder, insert lenses into previously drilled holes. Press firmly to ensure the lenses are fully seated.

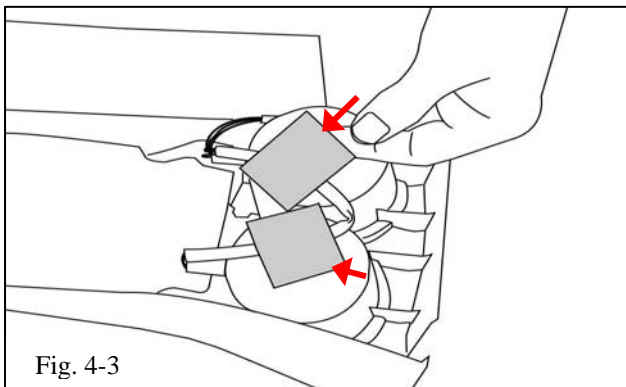

(d) From the back of console install the lock washers then the LED's onto the lenses.



(1) The LED housing with only 4 wires attached to it (the short harness) is installed to the driver side cup holder.

(2) Clean the bottom of the cup holder surfaces and secure the wires with 2 foam pads as shown. (Fig. 4-3)

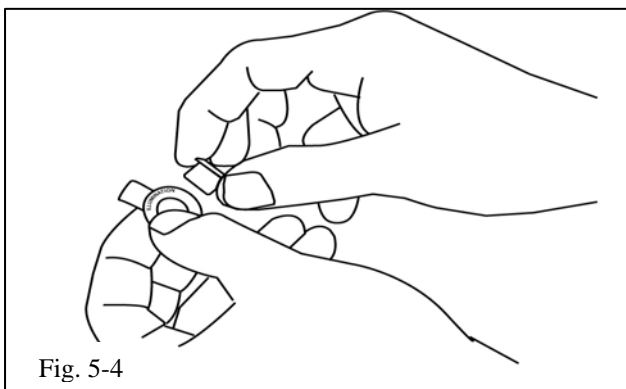
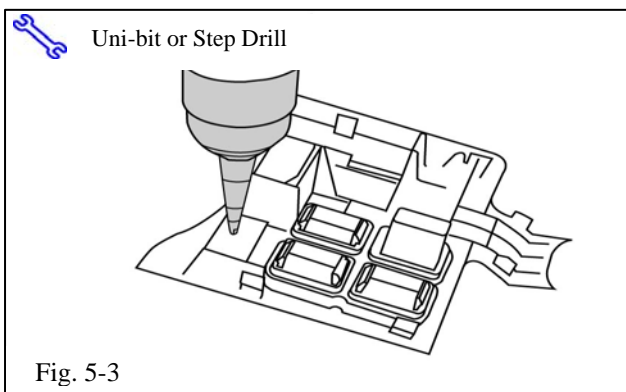
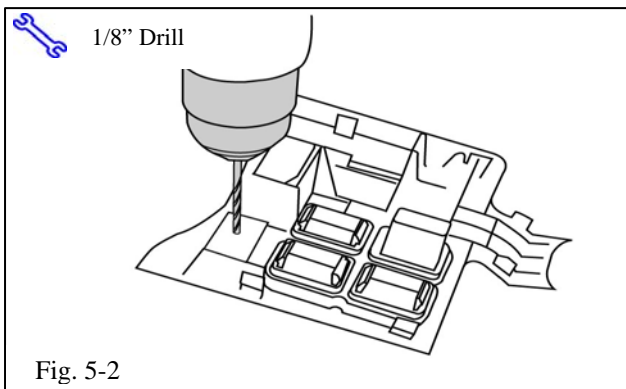
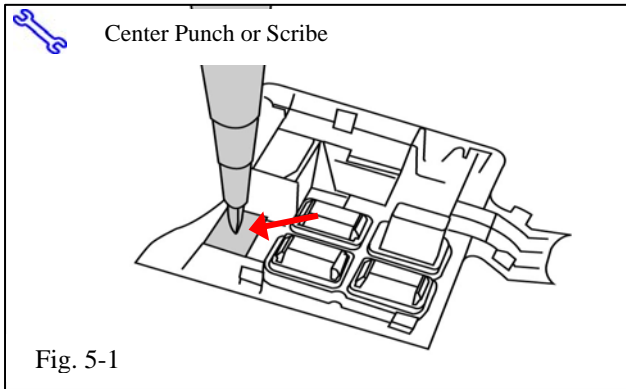

5. Installation of Switch and Harness.

(a) Use the switch template and mark the switch hole location in the switch cover using a punch or a scribe. (Fig. 5-1)

(b) Drill a pilot hole with a 1/8" drill bit. (Fig. 5-2)

(c) Using a 1/2" drill bit (Uni-bit or step bit is highly recommended) drill the switch hole. (Deburr the hole.) (Fig. 5-3)

NOTE: 1/2" hole can be drilled from the front side to reduce the need for deburring.

(d) Use VDC approved cleaner to clean switch cover surface.

(e) Insert the switch bezel into the round illumination plate. Using the Pull tab, remove the tape liner from the back of the illumination plate. Avoid contact with the adhesive surface. Install the bezel and the illumination plate onto the switch cover. (Fig. 5-4)

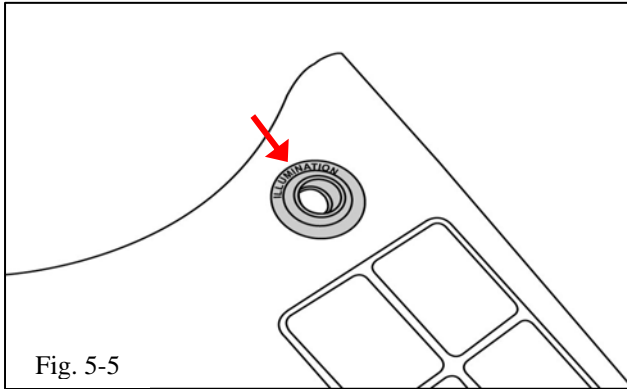

(f) Be sure the illumination plate is in proper alignment and not tilted either to the left or right (Fig. 5-5).

(1) Once aligned, press down firmly to adhere tape.

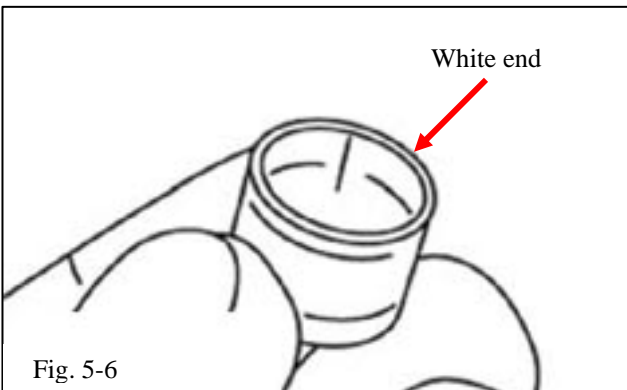

(g) Place switch spacer over switch bezel with the white end of spacer against switch panel. (Fig. 5-6)

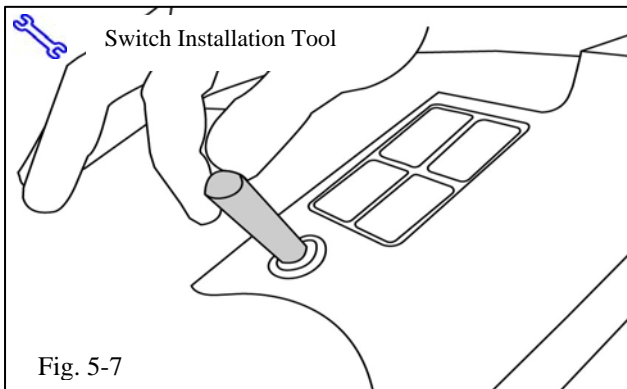

(h) Insert switch into bezel and use switch tool to tighten bezel to switch. (Fig. 5-7)

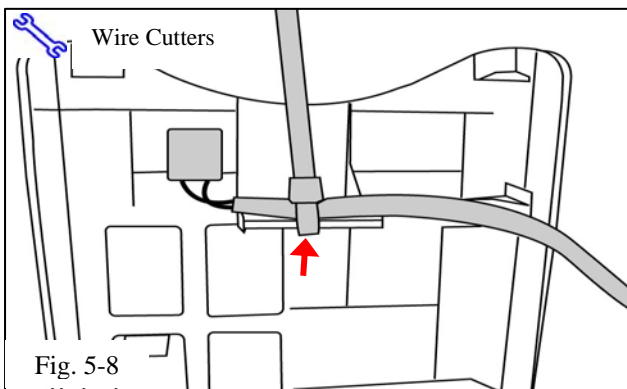

(i) Align leads as shown. Secure leads with a 7" wire tie. Trim excess wire tie. (Fig. 5-8)

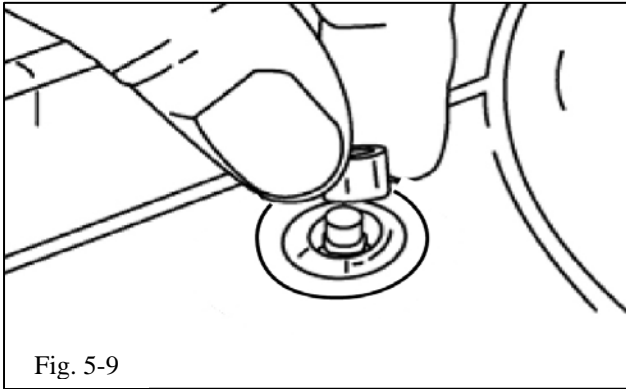

- (j) Install the button onto the switch by inserting it into the bezel and pressing to engage. (Fig. 5-9)

6. Installation of Controller Board.

- (a) Review wire harness connections. (Fig. 6-1)



- (1) Some wire harnesses are identified with a yellow connector, band, or label.



- (2) Some connectors on the controller board are identified with yellow marking or yellow connector.

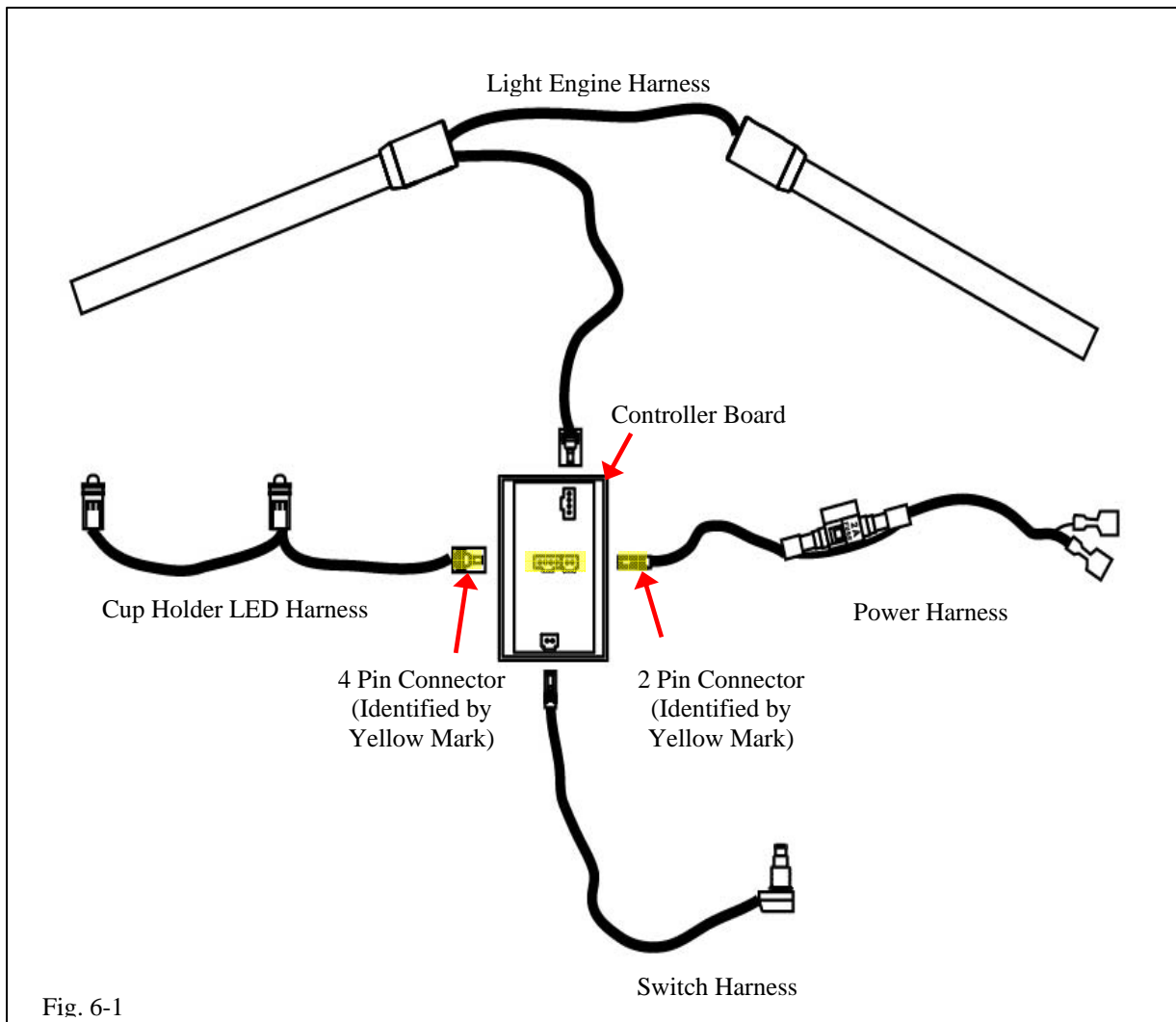

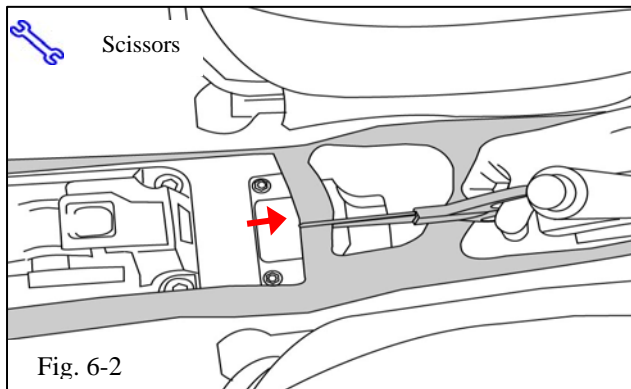

- (b) Cut carpet as shown and fold strips to side. (Fig. 6-2)

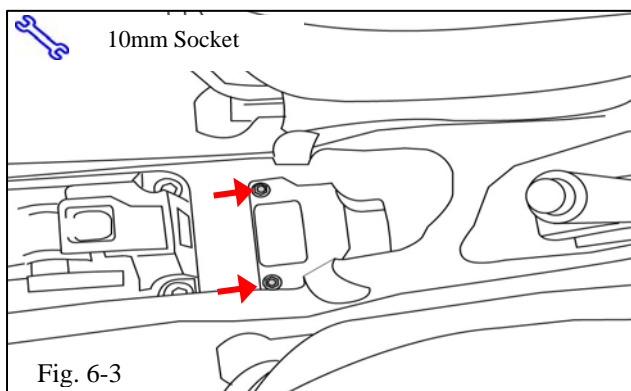

- (c) Remove the M6 nuts that secure the cover. (Fig. 6-3)

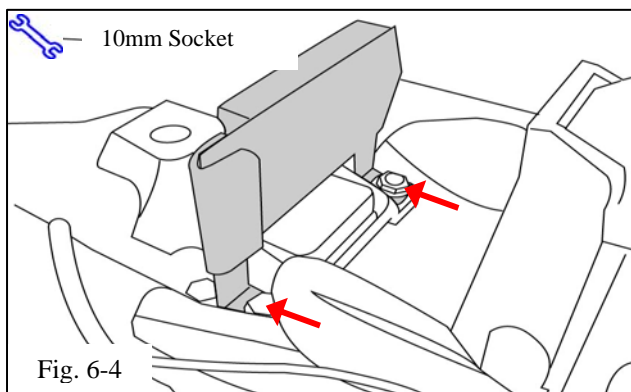

- (d) Install the controller board and bracket over the two mounting studs and secure bracket with the two M6 nuts. Torque to 9.0 N-m (80 lbf-in). (Fig. 6-4)

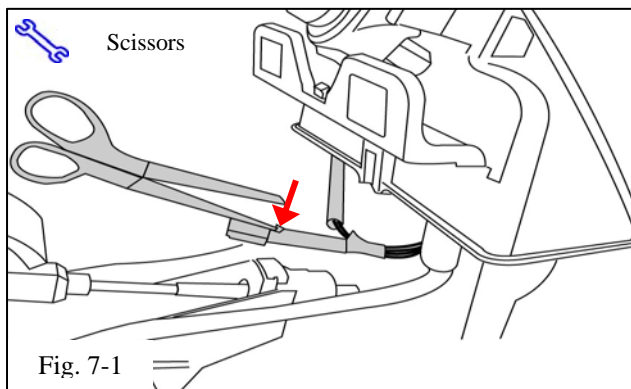

7. Installation of Power Harness.

- (a) Use a pair of scissors and cut the covering behind the power outlet connector. (Fig. 7-1)

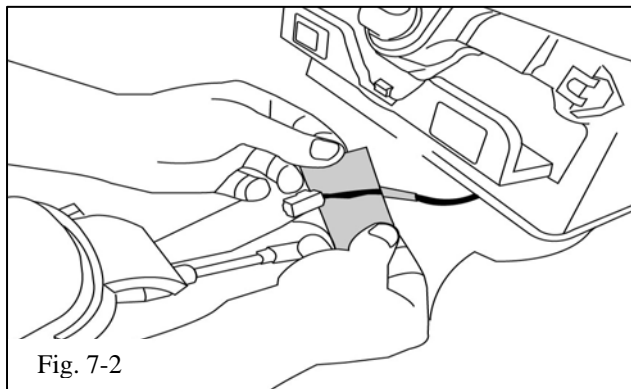

- (b) Separate the covering to expose the wire to the power outlet connector. (Fig. 7-2)

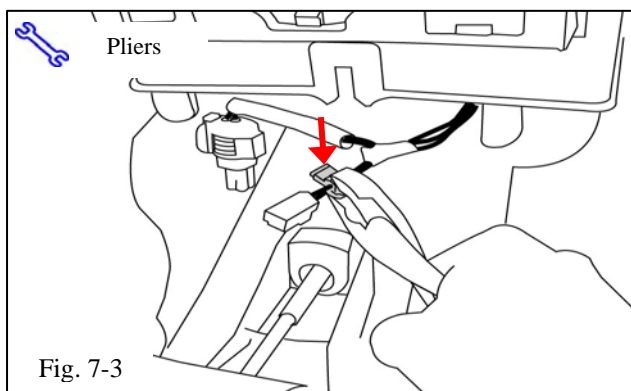

- (c) Install a T-Tap to each wire on the power outlet harness. (Fig. 7-3)

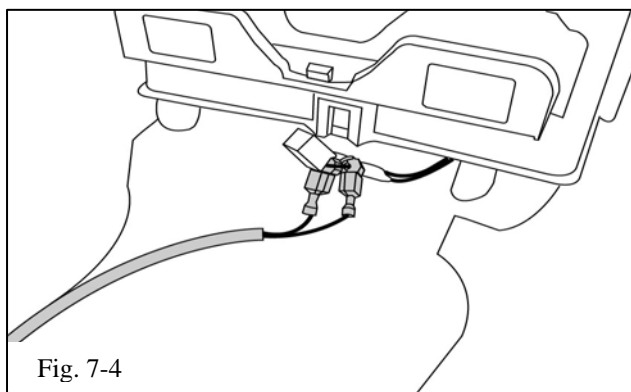

- (d) Connect the power harness with fuse to the T-Taps. (Fig. 7-4)
 - (1) Attach the white wire quick disconnect to the T-Tap attached to the grey wire.
 - (2) Attach the black wire quick disconnect to the T-Tap on the white/black wire.

- (e) Reinstall power outlet connector to power outlet socket.

- (f) Run power harness along vehicle harness on right side on vehicle center.

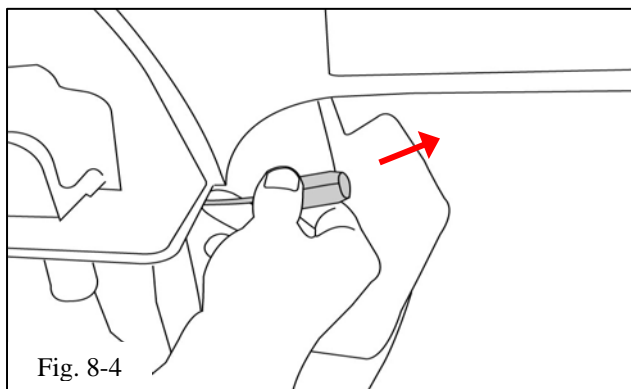
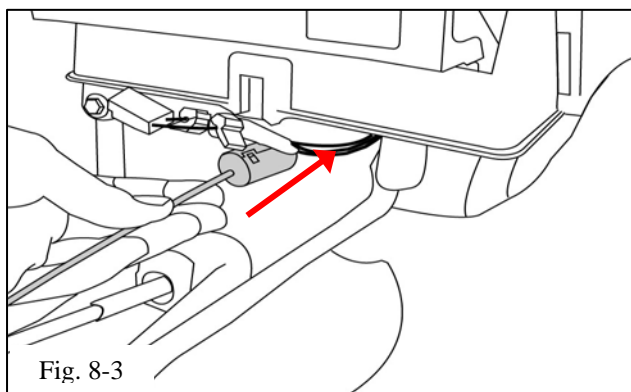
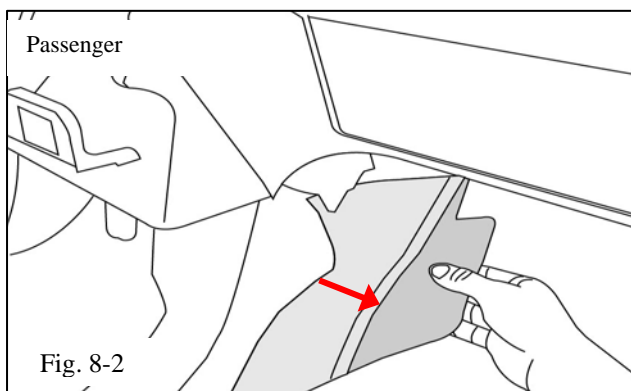
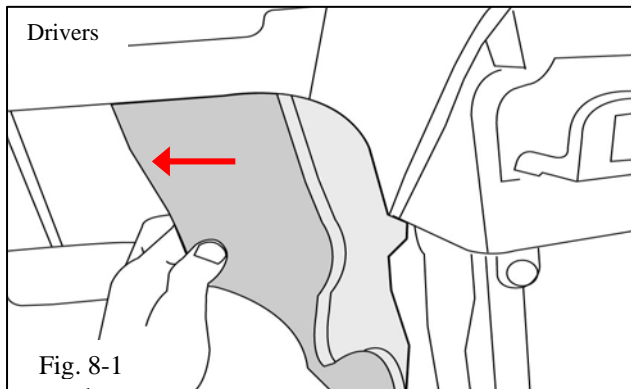

8. Installation of Light Engine Harness.

- (a) Pull back the carpeting covering the center of vehicle in the passenger and driver side footwells. (Fig. 8-1) (Fig. 8-2)

-  (b) The light engine with the single wire is routed under the center power outlet toward the passenger side footwell. (Fig. 8-3)

- (c) Passenger light engine is routed up behind the duct and toward blower motor located behind the glove box. (Fig. 8-4)

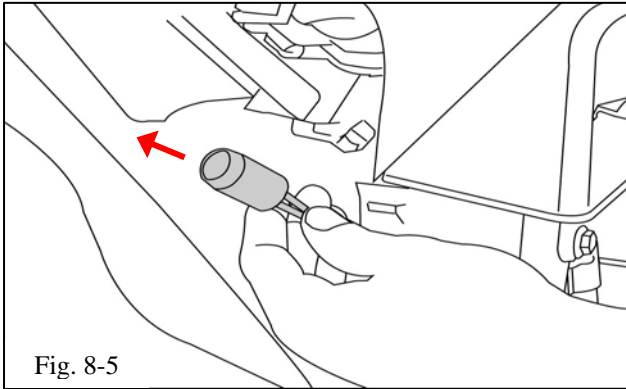

- (d) Light engine with 2 wires attached is routed under center power outlet, toward driver side footwell. (Fig. 8-5)

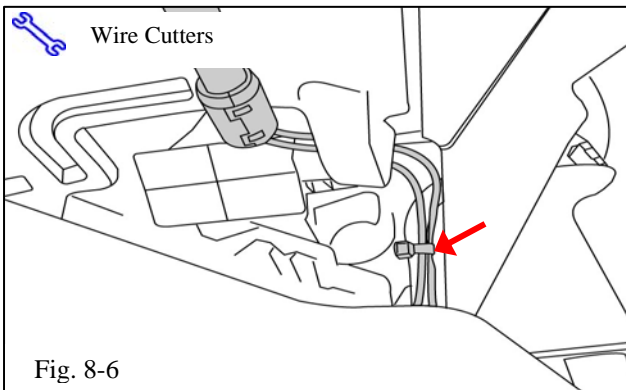

- (e) Attach light engine to driver side light rod attached to lower cover. Reinstall cover.
- (f) Route wires as shown and attach wires to vehicle harness with a 7" wire tie. (Fig. 8-6)

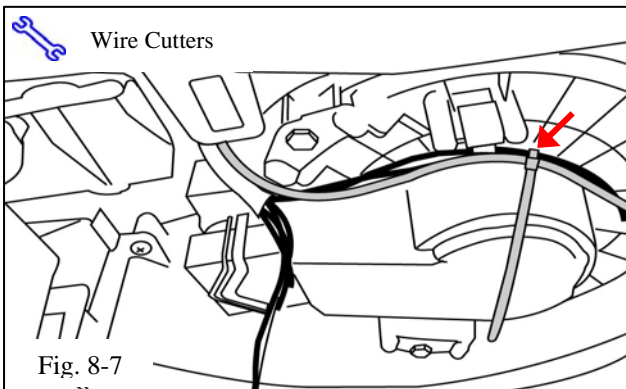

- (g) Route passenger light engine and attach wire to vehicle harness that runs to the blower motor, as shown. (Fig. 8-7)



- (1) Do not fully tighten.

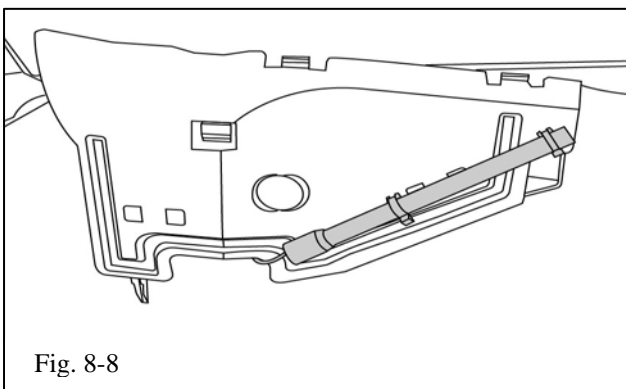

- (h) Attach the light engine to the light rod attached to passenger side lower cover. (Fig. 8-8)

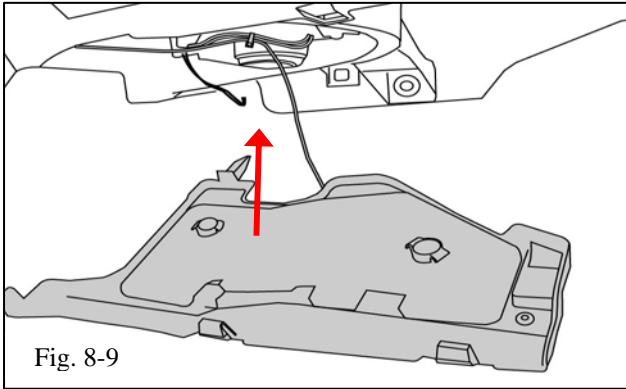

- (i) Pull back excess light engine wire until lower panel can be installed. Tighten wire tie on blower motor harness and trim excess. Install lower passenger cover. (Fig. 8-9)

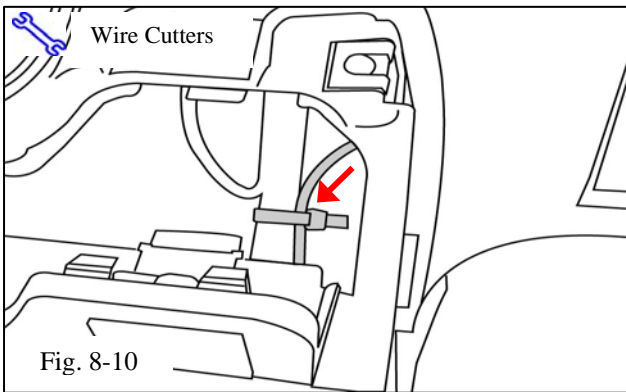

- (j) Secure light engine harness to vehicle harness behind iPod connector using a 7" wire tie. Trim excess wire tie. (Fig. 8-10)

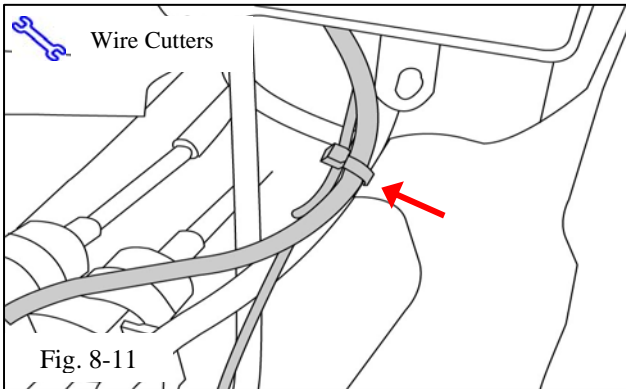

- (k) Secure the excess light engine wire that runs between the 2 light engines. Bundle the wire and secure to vehicle harness as shown, Trim excess wire tie. (Fig. 8-11)

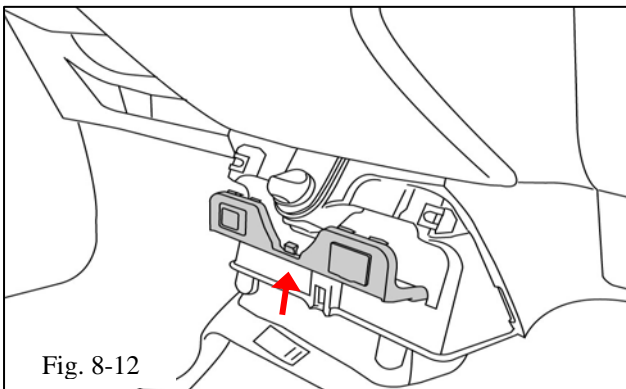

- (l) Reinstall iPod/Aux panel. (Fig. 8-12)

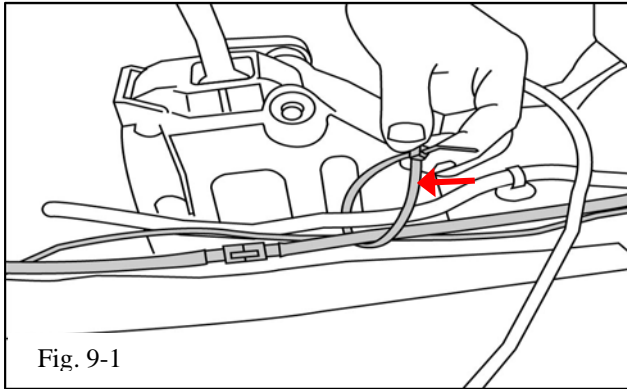

9. Installation of Center Console.

- (a) Install two 7” wire ties to vehicle harness on the right side of shifter. Leave a big loop. (Fig. 9-1)



(1) DO NOT TIGHTEN.

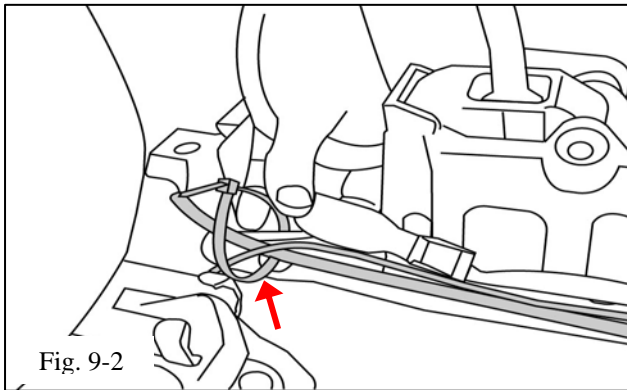

- (b) Locate the rear wire tie just before the controller board and front wire tie toward front of shifter. Run both the power harness and light engine harness through wire ties and toward the controller board. (Fig. 9-2)

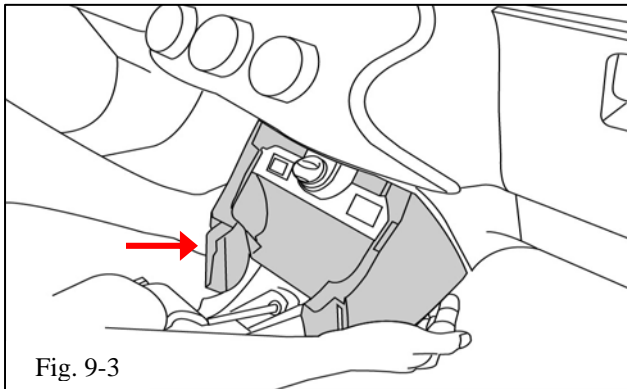

- (c) Reinstall the front console. (Fig. 9-3)

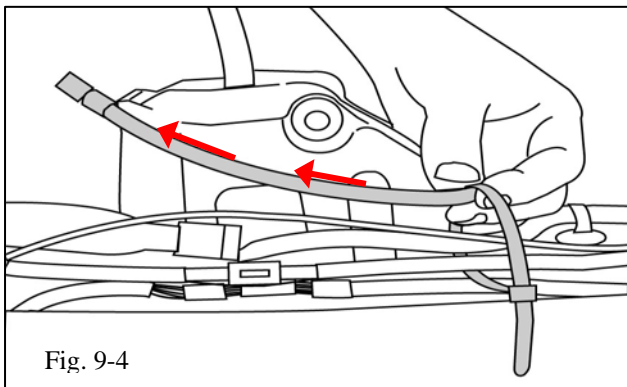

- (d) Place center console into position to be reinstalled above shifter. Run cup holder harness toward rear of console.
 - (1) Feed the harness through the previously installed 7” wire ties. (Fig. 9-4)

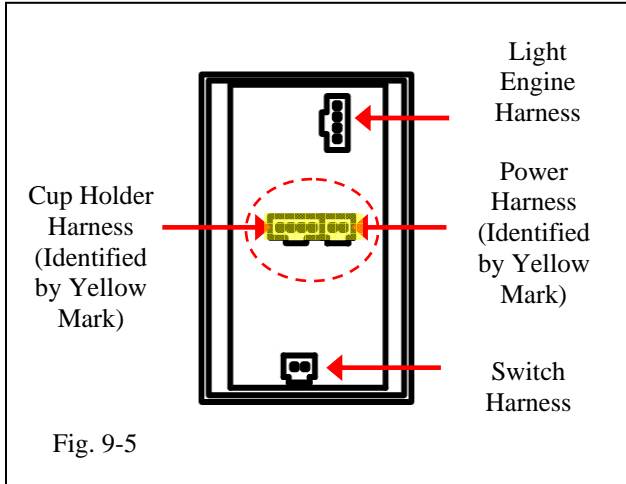

- (e) Locate control board. Review connectors on controller board. (Fig. 9-5)



CAUTION: Failure to connect wire harnesses in the correct locations may result in permanent damage to light engine assemblies.

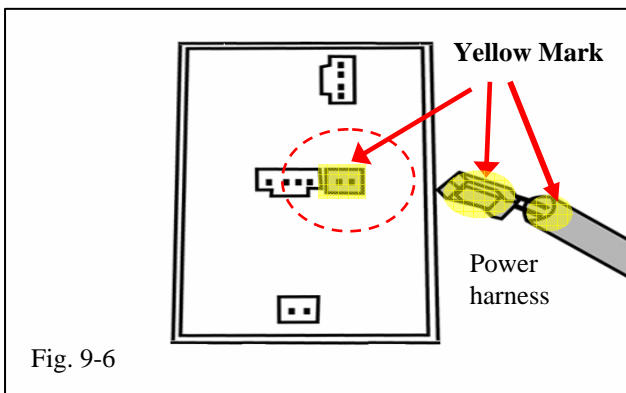

- (f) Plug in the 2 pin Power harness identified by a yellow mark to the 2 pin connector on the controller board with the yellow mark. (Fig. 9-6)

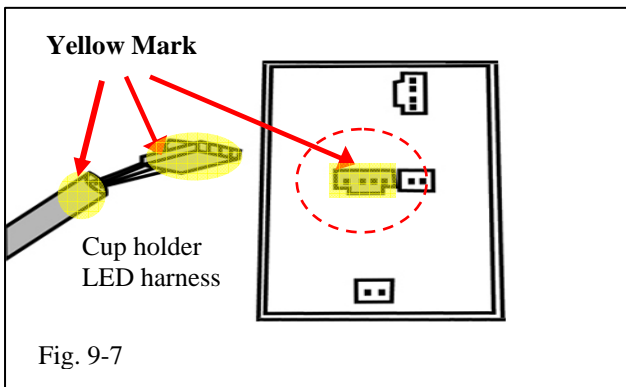

- (g) Plug in the 4 pin cup holder connector identified by a yellow mark to the 4 pin connector on the control board with the yellow mark. (Fig. 9-7)

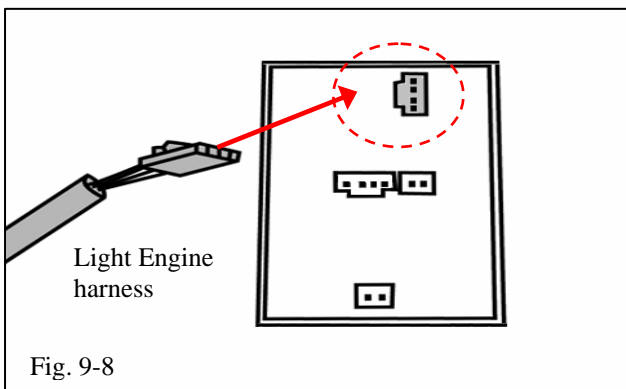

- (h) Plug in the 4 pin Light engine harness connector to the plain black 4 pin connector on the control board. (Fig. 9-8)

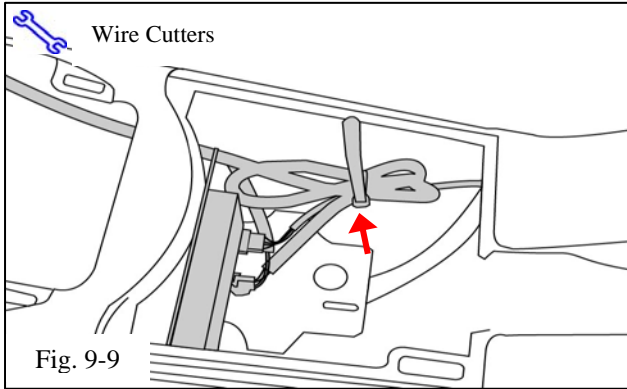

- (i) Bundle excess wire with a 7" wire tie. Trim excess wire tie. (Fig. 9-9)

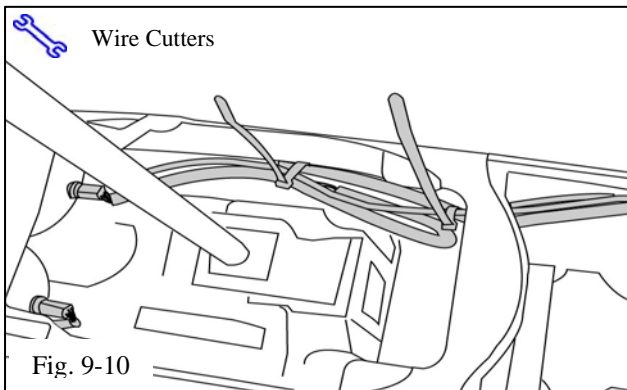

- (j) Tighten the two 7" wire ties to the right of shifter. Trim excess wire tie. (Fig. 9-10)
- (k) Install center console.

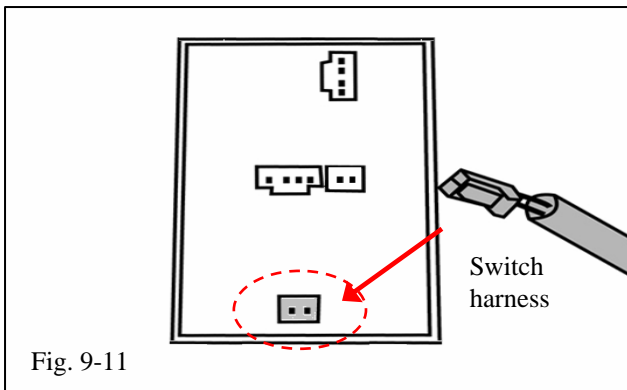

- (l) Plug in the 2 pin switch harness connector to the plain black 2 pin connector on the controller board. (Fig. 9-11)

- (m) Install switch panel.



- (1) Reconnect all disconnected connectors to the switch panel.
- (n) Attach trim pieces. Secure mounting screws and bolts.
- (o) Attach Shift knob.

10. Post installation.

- (a) Reconnect negative battery terminal and torque to 4.1 N-m (36 lbf-in).
- (b) Clean light guide using approved cleaner and non-scratch cloth.
- (c) Cycle test the system with key in ACC or ON. The cycle may start from any step below but should cycle as follows:
 - (1) System advances in color with each push of the button.
 - (2) Note: There are 4 colors (Orange, Blue, Green, Red) and an Off position.
- (d) Check interior trim panels for proper fit and alignment.

Checklist - these points **MUST** be checked to ensure a quality installation.

Check: _____

Look For: _____

Accessory Function Checks

Light Kit, Partial Operation

Light Kit, No Operation

- Full engagement of affected wire harness connector at the controller board.
- Correct installation of harness locations at the controller board.

Note: positioning the light engine harness connector in the wrong location will result in permanent damage to the light engines.

- Confirm light guide has been installed with the reflector on the end opposite the light engine.
- Vehicle key in the ACC or On Position.
- Vehicle battery connection.
- Full engagement of power harness connector at the controller board.
- Full engagement of power harness connector at the Power Outlet.
- Blown Power Outlet fuse (see vehicle owner’s manual for Amperage and location).
- Blown light kit fuse (2A mini blade)
- Full engagement of switch harness connector at the controller board.
- Full engagement of any other switches removed on switch panel.

Vehicle Function Checks

- Power Outlet Not Operational
- Traction and Vehicle Stability Control
- Security System

Power outlet should function properly.

Check for proper operation of the VSC switch.

Check for proper operation of the security system.

APPENDIX 1

