

**Part Number: PTR31-89060**

**Kit Contents**

Item #	Quantity Reqd.	Description
1	1	Front Muffler Assembly
2	1	Rear Tailpipe Assembly
3	1	Hardware Bag

**Hardware Bag Contents**

Item #	Quantity Reqd.	Description
1	1	Gasket 23000-00035
2	2	M10x1.5x35 mm long Hex Head Bolts
3	2	M10x1.5 Hex Nuts
4	4	M10 Flat Washers
5	1	Installation Instructions

**Additional Items Required For Installation**

Item #	Quantity Reqd.	Description
1		

**Conflicts**

--

**Recommended Tools**

<b>Personal &amp; Vehicle Protection</b>	<b>Notes</b>
None	
<b>Special Tools</b>	<b>Notes</b>
Exhaust Hanger Removal Tool	e.g. Snap On P/N YA3202
<b>Installation Tools</b>	<b>Notes</b>
Socket	14 mm, 16 mm, 17 mm
Wrenches	14 mm, 16 mm, 17 mm
Torque Wrench	50 lbf.ft
<b>Special Chemicals</b>	<b>Notes</b>
Lubricant	Soap and Water

**General Applicability**

2006MY V6 4Runner: PTR31-89060
--------------------------------

**Recommended Sequence of Application**

Item #	Accessory
1	

\*Mandatory

**NOTE:** Part number of this accessory may not be the same as the part number shown.

**Vehicle Service Parts** (may be required for reassembly)

Item #	Quantity Reqd.	Description
1	1	Front Flange Gasket PN: 17451-74051 – DIO ONLY
2		
3		

**Legend**



**STOP:** Damage to the vehicle may occur. Do not proceed until process has been complied with.



**OPERATOR SAFETY:** Use caution to avoid risk of injury.



**CAUTION:** A process that must be carefully observed in order to reduce the risk of damage to the accessory/vehicle and to ensure a quality installation.



**TOOLS & EQUIPMENT:** Used in Figures calls out the specific tools and equipment recommended for this process.

Care must be taken when installing this accessory to ensure damage does not occur to the vehicle. The installation of this accessory should follow approved guidelines to ensure a quality installation.

These guidelines can be found in the "Accessory Installation Practices" document.

This document covers such items as:-

- Vehicle Protection (use of covers and blankets, cleaning chemicals, etc.).
- Safety (eye protection, rechecking torque procedure, etc.).
- Vehicle Disassembly/Reassembly (panel removal, part storage, etc.).
- Electrical Component Disassembly/Reassembly (battery disconnection, connector removal, etc.).

Please see your Toyota dealer for a copy of this document.

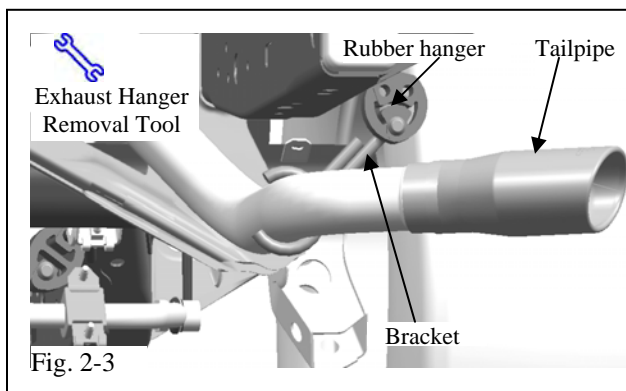
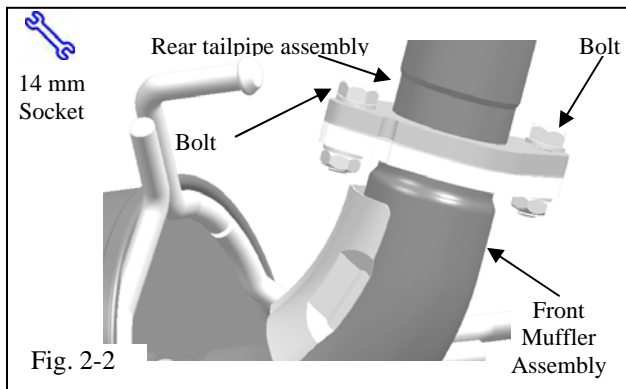
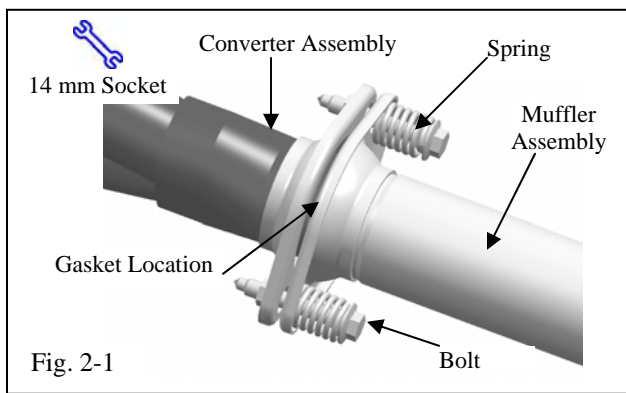

### 1. Check the Kit content.

- STOP (a) Make sure that the kit contains all the parts listed in the Kit Contents.

### 2. Remove Existing Exhaust System.

- (a) Using the 14mm socket, remove two bolts with springs from front flange located between catalytic converter and rear muffler. (Fig. 2-1)

- ! (b) Keep all original equipment (OE) bolts and springs. (Fig. 2-1)

- ! (1) Ensure that the original gasket remains on converter assembly flange

**NOTE:** For DIO, installation gasket **must** be replaced – P/N 17451-74051.

- (c) Using the 14mm socket, remove and discard two bolts from rear flange located between muffler assembly and rear tailpipe assembly. (Fig 2-2)

- (d) Pry the rear tailpipe exhaust bracket loose from the rubber hanger located near the rear bumper. (Fig. 2-3)

- (e) Remove the OE rear tailpipe assembly from the vehicle.

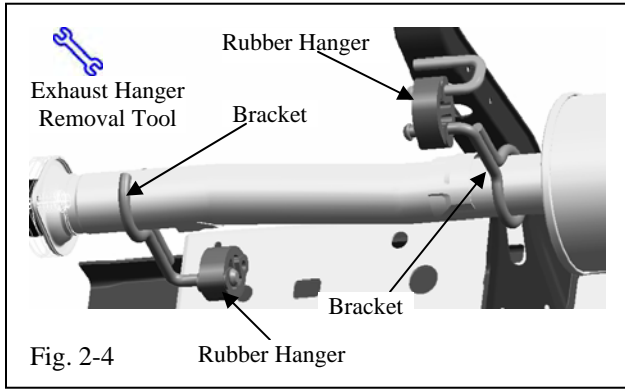

- (f) Pry the two front muffler exhaust brackets loose from the rubber hangers. (Fig. 2-4)

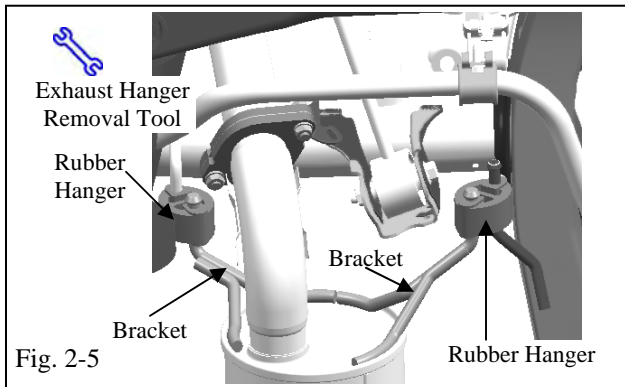

- (g) Pry the two rear muffler exhaust brackets loose from the rubber hangers. (Fig 2-5)

**NOTE:** Use of lubrication (such as “soap and water”) on the rubber exhaust hangers can facilitate removal and installation of rubber hangers.

- (h) Do not remove the five (5) original (OE) rubber hangers from the vehicle.
- (i) Remove the OE front muffler assembly from the vehicle.

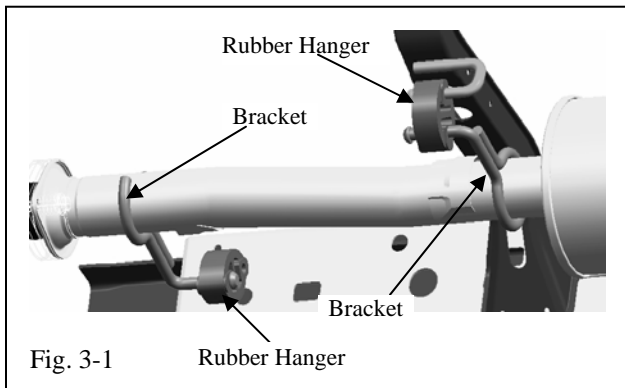

**3. Installation of TRD Exhaust System.**

- (a) Connect the two front muffler hangers of the TRD muffler assembly to OE rubber hangers. (Fig. 3-1)

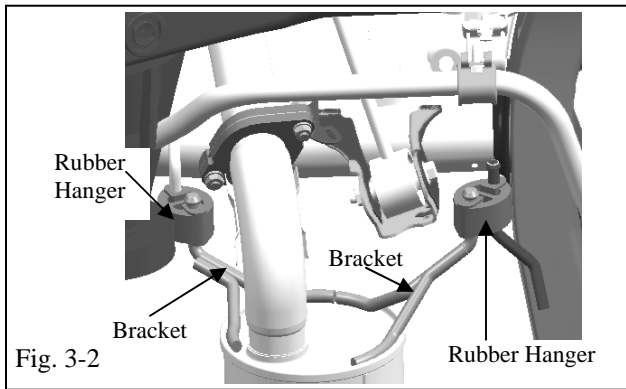

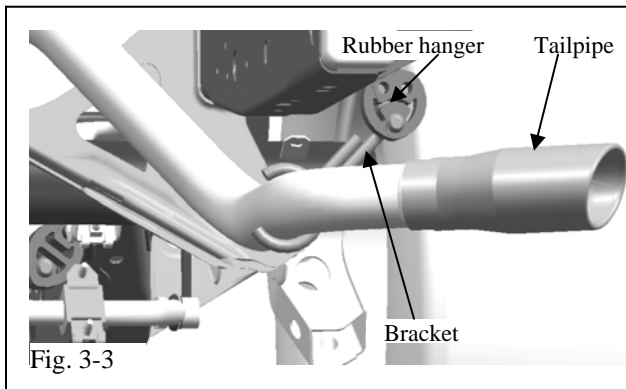

(b) Connect the two rear muffler hangers to OE rubber hangers. (Fig. 3-2)

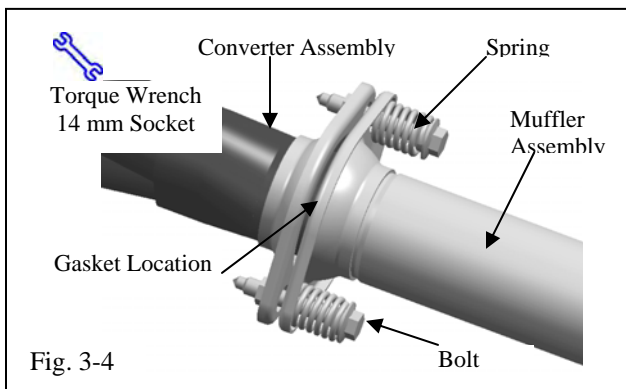

- (c) Connect TRD tailpipe hanger to OE rubber hanger. (Fig. 3-3)
- (d) Make sure TRD muffler front flange is lined up to converter assembly flange.
- (e) Make sure rear flange between front muffler assembly and rear tailpipe assembly is lined up.



-  (f) Install muffler front flange to connect to OE front converter assembly. Reinstall two (2) OE springs and bolts evenly for proper flange alignment. (Fig. 3-4)
-  (g) Tighten bolts to 32 lbf-ft (43N-m) (Fig. 3-4).

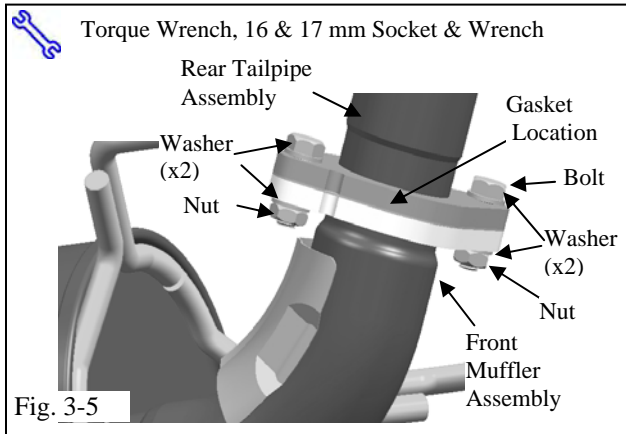

- (h) Install supplied gasket P/N 23000-00035 on the rear flange of the muffler. (Fig. 3.5)
- (i) Connect the rear tailpipe assembly to the muffler rear flange and securely fasten the flange connection, using bolts and nuts supplied in the kit. (Fig. 3-5)
  - (1) Using the 16 & 17mm socket & wrench, install two supplied washers between the bolts and the upper flange, and two washers between the nuts and the lower flange.
- (j) Tighten bolts to 25 lbf-ft (34N-m) (Fig. 3-4).

Checklist - these points **MUST** be checked to ensure a quality installation.

Check:



Look For:

Accessory Function Checks

- Correct part has been installed.
- All joints have been securely fastened.
- Hooks/hangers have been securely reattached.
- Start the vehicle.

- Verify part number on package.
- Verify joints are tightened.
- Verify hooks/hangers are securely attached.
- Verify the flange joints do not have abnormal leak sound or water leak.

Vehicle Function Checks

-   Inspection torque - muffler to converter assembly.
-   Inspection torque – tailpipe assembly to outlet flange.

- 32+/- 5 lbf-ft (43 +/- 6 N-m).
- 25+/- 5 lbf-ft (34 +/- 6 N-m).

