

Part Number: PTR11-52081

Kit Contents

Item #	Quantity Reqd.	Description
1	2	Front Springs
2	2	Rear Springs
3	1	Instruction Form

Hardware Bag Contents

Item #	Quantity Reqd.	Description
1		
2		
3		

Additional Items Required For Installation

Item #	Quantity Reqd.	Description
1	4	Nut, front shock absorber – Toyota P/N 90179-12145
2		
3		

Conflicts

None

Recommended Tools

Personal & Vehicle Protection	Notes
Jack Stand	
Fender Cover	
Special Tools	Notes
Spring Compressor	
Vehicle Lift or Floor Jack	
Installation Tools	Notes
Torque wrench	$\frac{3}{8}$ " & $\frac{1}{2}$ "
Sockets	10,14,17,22mm
17 mm deep offset box end wrench	
6 mm allen wrench	
Special Chemicals	Notes

General Applicability

SCION xD





Recommended Sequence of Application

Item #	Accessory
1	TRD Springs
2	TRD Rear Sway Bar
3	

Vehicle Service Parts (may be required for reassembly)

Item #	Quantity Reqd.	Description
1		
2		
3		

Legend

	STOP: Damage to the vehicle may occur. Do not proceed until process has been complied with.
	OPERATOR SAFETY: Use caution to avoid risk of injury.
	CAUTION: A process that must be carefully observed in order to reduce the risk of damage to the accessory/vehicle and to ensure a quality installation.
	TOOLS & EQUIPMENT: Used in Figures calls out the specific tools and equipment recommended for this process.
	REVISION MARK: This mark highlights a change in installation with respect to previous issue.

Care must be taken when installing this accessory to ensure damage does not occur to the vehicle. The installation of this accessory should follow approved guidelines to ensure a quality installation.

These guidelines can be found in the "Accessory Installation Practices" document.

This document covers such items as:-

- Vehicle Protection (use of covers and blankets, cleaning chemicals, etc.).
- Safety (eye protection, rechecking torque procedure, etc.).
- Vehicle Disassembly/Reassembly (panel removal, part storage, etc.).
- Electrical Component Disassembly/Reassembly (battery disconnection, connector removal, etc.).

Please see your Toyota dealer for a copy of this document.

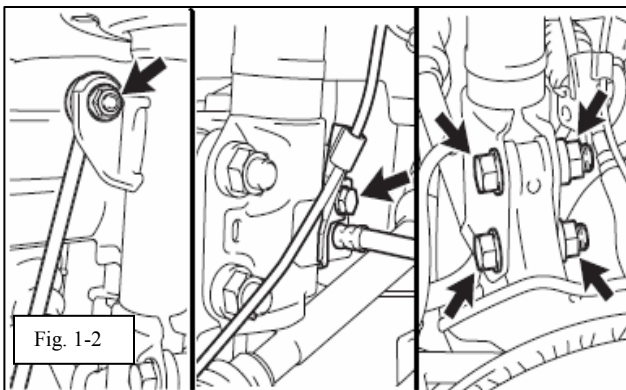
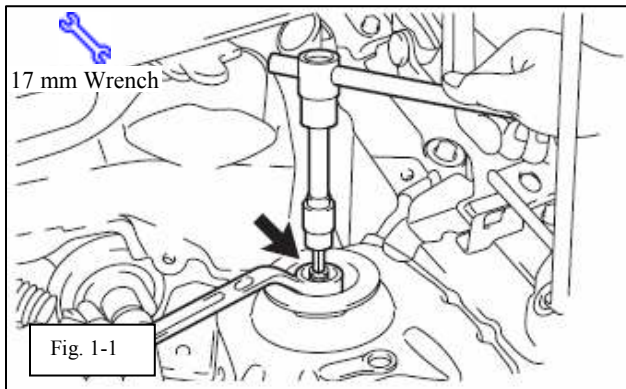

1. REMOVE FRONT STRUT ASSEMBLY

- (a) Loosen upper strut assy nut.
 - (1) Using a 6 mm allen wrench, hold the center rod in place and loosen the nut with a deep offset wrench (Fig 1-1). Do NOT remove the nut yet.
- (b) Remove front wheels.
- (c) Separate front stabilizer link from the strut assy. If the ball joint spins use an allen wrench to hold the center stud in place.
- (d) Separate front flexible hose and speed sensor wire if equipped.
- (e) Disconnect strut assy from knuckle. (Fig 1-2)
- (f) Remove strut assy.
 - (1) Supporting the weight of the strut assy remove the top nut by hand and pull the strut assy out of the wheel well.

2. STRUT DISASSEMBLY

- ✚ (a) Compress spring in spring compressor.
- (b) Remove upper nut, coil spring seat, jounce bumper, and insulator.
- (c) Remove original spring.

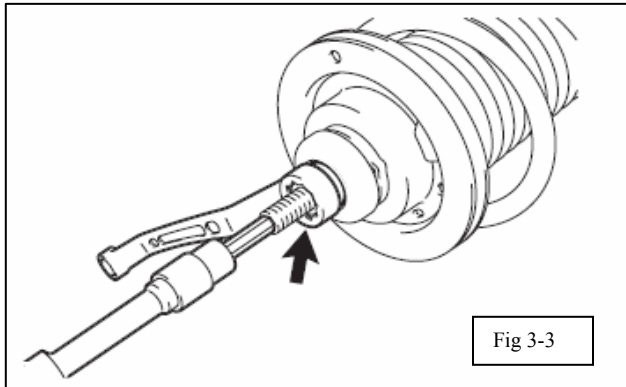
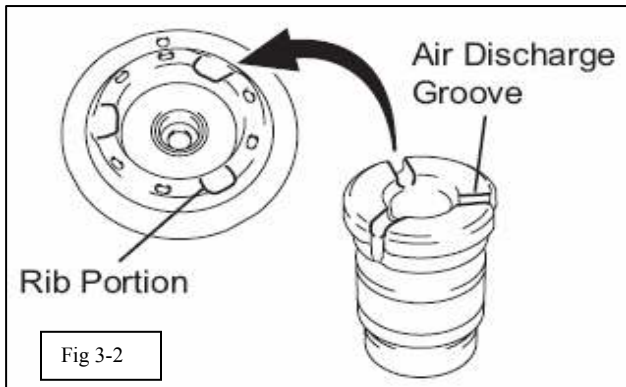
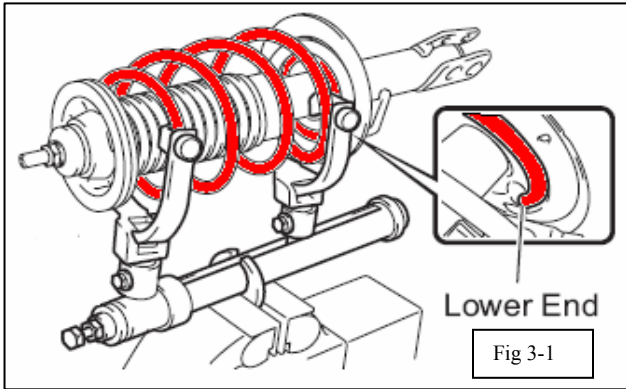

3. ASSEMBLE STRUT

- (a) Install front TRD spring.
 - (1) Take note of the OE spring orientation being pulled off the strut. The new TRD spring will have the same “open” winding at the bottom.
 - (2) Fit this “open” winding into the pocket of the shock absorber lower seat. (Fig. 3-1)
- (b) Install front coil spring insulator upper.
- (c) Install front spring jounce bumper.
 - (1) Push the spring bumper into the coil spring seat upper. (Fig. 3-2)
- (d) Install the coil spring seat upper with the strut mount bearing and spring jounce bumper onto the shock absorber.
- (e) Install new shock absorber nut (Fig 3-3)

Torque: 33N*m (340 kgf*cm, 25 ft.*lbf)

4. INSTALL FRONT STRUT ASSEMBLY

- (a) Raise strut up into wheel well and hand start upper nut. Leave assembly loose for now.
- (b) Attach strut assembly to knuckle with 2 bolts and 2 nuts.
 - (1) You have the option to push the assembly inward on vehicle while tightening the nuts to get more negative camber.

Torque: 164 N*m (1,672 kgf*cm, 121 ft.*lbf)

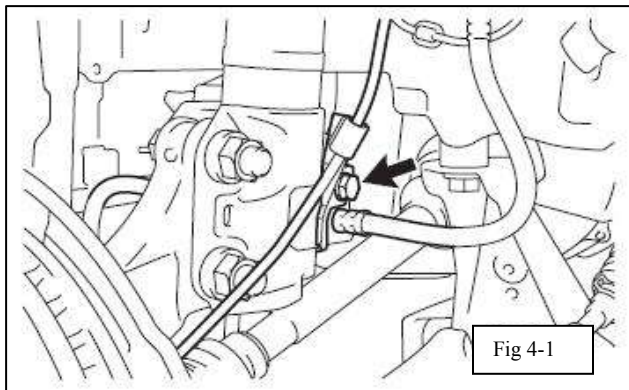

Fig 4-1

- (c) Attach front flexible brake hose and speed sensor if equipped. (Fig 4-1)
 - (1) Install the flexible hose and speed sensor without twisting them.

Torque: 29 N*m (300 kgf*cm, 22 ft.*lbf)

- (d) Attach front stabilizer link assembly.
 - (1) If the ball joint turns together with the nut, use a 6 mm allen wrench to hold the stud.

Torque: 74 N*m (755 kgf*cm, 55 ft.*lbf)

- (e) Install front wheel.

Torque: 103 N*m (1,050 kgf*cm, 76 ft.*lbf)

- (f) Now go back to the upper strut mounting nut and tighten it. (Fig. 4-2)

Torque: 55 N*m (561 kgf*cm, 41 ft.*lbf)

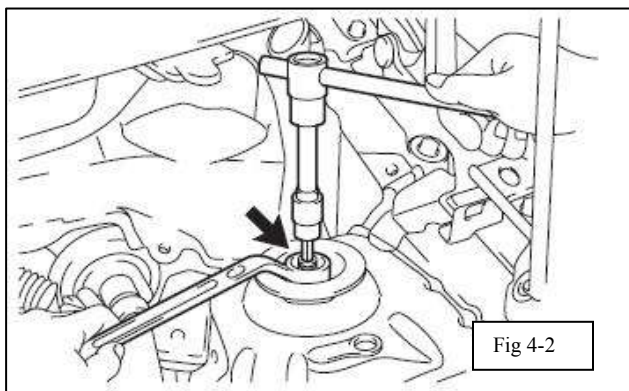

Fig 4-2

5. REPLACE REAR SPRINGS

- (a) Separate skid control sensor wire from beam axle if equipped. (Fig. 5-1)
- (b) Disconnect lower shock eye from axle beam.
 - (1) Loosen the bolt **NOT** the nut.
 - (2) Only work on one side at a time to prevent the axle beam from swinging too low and put unwanted tension on the brake lines or beam axle bushings.

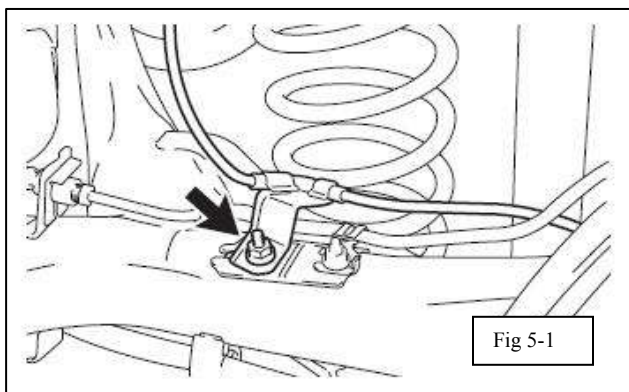

Fig 5-1



- (c) Remove original spring
- (d) Install rear spring insulators.
 - (1) Confirm lower coil spring insulator is seated properly on the beam axle.
 - (2) Install the coil spring insulator upper so that its pocket fits onto the end of the coil spring. (Fig. 5-2)

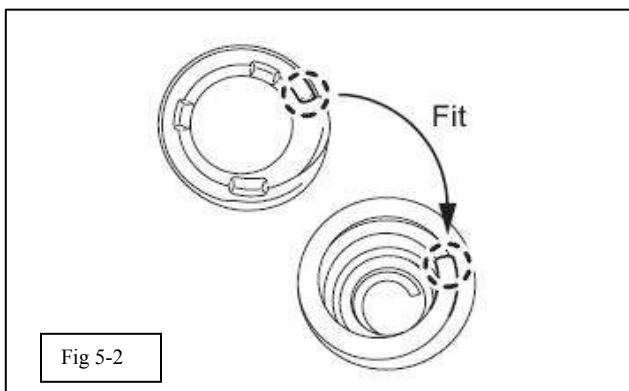

Fig 5-2

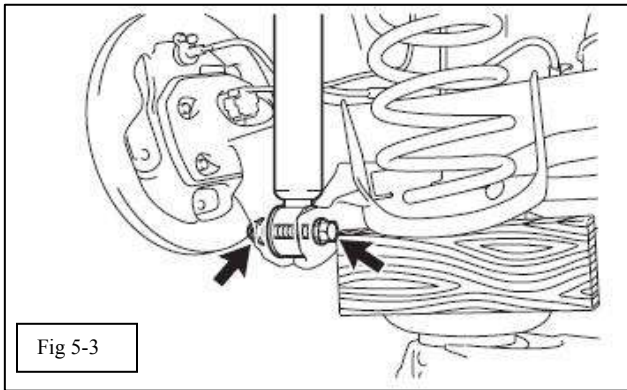

Fig 5-3

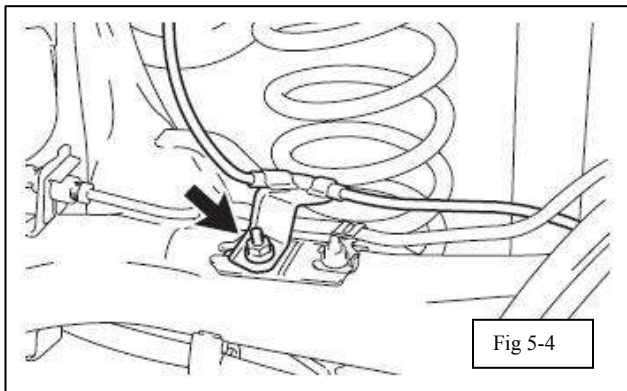

Fig 5-4

- (e) Install coil spring onto axle beam
 - (1) Position the tightly wound coils facing the top of the vehicle
 - (2) Make sure the bottom ends of the springs are indexed the same left and right. This will ensure equal ride height. The ends of the springs should be at the 3 o'clock position.

(f) Install rear shock absorber lower. (Fig 5-3)

Torque: 49 N*m (500 kgf*cm, 36 ft.*lbf)

(g) Attach skid control sensor wire if equipped. (Fig 5-4)

Torque: 5 N*m (51 kgf*cm, 44 in.*lbf)

6. Align Vehicle

- (a) Take vehicle to local Toyota/SCION dealer for proper alignment.

Front		
Toe-in	Total toe	1.4 +/- 2.0 mm (0.06 +/- 0.08 in.)
	Rack end length difference	1.5 mm (0.059 in.) or less
Camber		-0°11' +/- 45' (-0.18° +/- 0.75°)
Caster		4°51' +/- 45' (4.85° +/- 0.75°)
Rear		
Toe-in		3.4 +/- 3.0 mm (0.13 +/- 0.11 in.)
Camber		-0°57' +/- 30' (-0.95° +/- 0.5°)

Checklist - these points **MUST** be checked to ensure a quality installation.

Check:

Look For:

Accessory Function Checks

- Test drive vehicle and confirm there is no unwanted noise from the suspension
-
-

Clunks, Creaks, Rattles

Vehicle Function Checks

- Test drive vehicle and confirm there is no unwanted noise from the suspension
- Confirm vehicle alignment is within specification
-
-

Clunks, Creaks, Rattles