

Part Number: PTR11-34070-01 (FRONT)
PTR11-34070-02 (REAR)
PTR11-34070-03 (SPRING)

NOTE: Part number of this accessory may not be the same as the part number shown.

Kit Contents

Part #	Quantity Req'd.	Description
PTR11-34070-01	1	Tundra Lowering System – Front Kit: 2 front springs, 2 front shocks, 4 front bump stops w/ hardware, 2 rear bump stops, 2 pinion shims
PTR11-34070-02	1	Tundra Lowering System – Rear Kit: 1 rear sway bar w/ hardware, 2 rear shocks
PTR11-34070-03	2	Tundra Lowering System – Rear Leaf Spring

Recommended Sequence of Application

Item #	Accessory
1	Tundra Lowering System – Front Kit
2	Tundra Lowering System – Rear Leafs
3	Tundra Lowering System – Rear Kit

*Mandatory

Vehicle Service Parts (may be required for reassembly)

Item #	Quantity Req'd.	Description
1		

Additional Items Required For Installation

Item #	Quantity Req'd.	Description
1	2	Front Shock Top Nut – PN: 90177-A0007
2		

Conflicts / Notes:

- All 3 kits above must be used to ensure proper installation and functionality of the TRD Performance Lowering Kit.
- The Rear Sway Bar in this kit **CAN NOT** be installed with vehicles equipped with the following Genuine Accessory Hitches (**Refer to PANT Bulletin # 07-32**):
PT228-34073: Resin Bumper Genuine Hitch
PT228-34074: Steel Bumper Genuine Hitch

Legend



STOP: Damage to the vehicle may occur. Do not proceed until process has been complied with.



OPERATOR SAFETY: Use caution to avoid risk of injury.



CAUTION: A process that must be carefully observed in order to reduce the risk of damage to the accessory/vehicle and to ensure a quality installation.



TOOLS & EQUIPMENT: Used in Figures calls out the specific tools and equipment recommended for this process.



REVISION MARK: This mark highlights a change in installation with respect to previous issue.



SAFETY TORQUE: This mark indicates that torque is related to safety.

Recommended Tools

Personal & Vehicle Protection	Notes
Vehicle Protection	Seat/Floor Covers
Safety Glasses	
Special Tools	Notes
Installation Tools	Notes
Socket/Ratchet	16 mm - 23mm
Box Wrench	16 mm - 23mm
Torque Wrench	0- 150 lbf.ft (0 - 204 N.m)
Allen Socket	8mm
Special Chemicals	Notes
Cleaner (for clean up)	3M Prep Sol-70

General Applicability

ALL 2WD TUNDRA TRUCKS – Conflicts with “OFF ROAD” Package and all 4x4 Tundra

Care must be taken when installing this accessory to ensure damage does not occur to the vehicle. The installation of this accessory should follow approved guidelines to ensure a quality installation.

These guidelines can be found in the "Accessory Installation Practices" document.

This document covers such items as:-

- Vehicle Protection (use of covers and blankets, cleaning chemicals, etc.).
- Safety (eye protection, rechecking torque procedure, etc.).
- Vehicle Disassembly/Reassembly (panel removal, part storage, etc.).
- Electrical Component Disassembly/Reassembly (battery disconnection, connector removal, etc.).

Please see your Toyota dealer for a copy of this document.

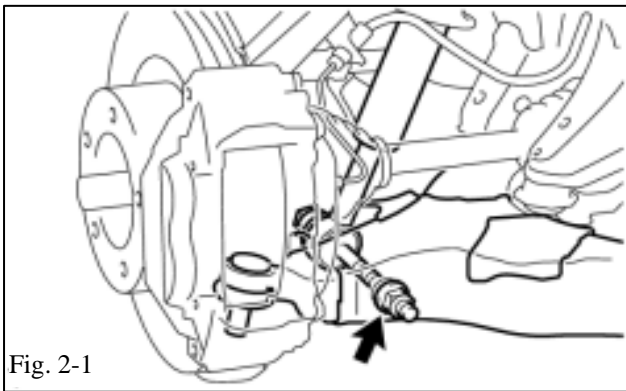

Fig. 2-1

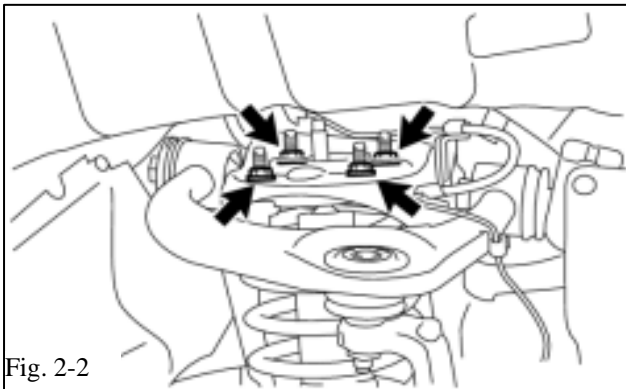

Fig. 2-2

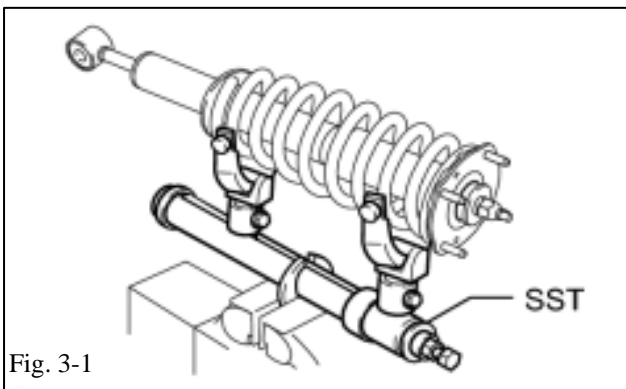

Fig. 3-1

1. Check the Kit content.

- (a) Make sure that the kit contains all the parts listed in the Kit Contents.

2. Remove OE Front Springs and Shocks

NOTE: Use the same procedures below for the RH side and LH side.

- (a) Secure vehicle on lift, and remove front wheels
- (b) Remove the nut and bolt from the shock absorber lower side. (Fig. 2-1)
 - (1) To prevent the shock absorber with coil spring from falling, leave the bolt inserted.

- (c) Remove the top 4 nuts. (Fig. 2-2)

- (d) Remove the bolt (lower side) and OE shock absorber with coil spring.

- (e) Repeat steps 2(b) – 2(d) on opposite side.

3. Disassemble OE Front Springs and Shocks

- (a) Using one of the SST's listed, compress the coil spring.(Fig. 3-1)

- (1) Approved SST: 09727-30021, 09727-00010, 09727-00021, 09727-00031

- (2) Make sure that the suspension support is free from the coil spring.

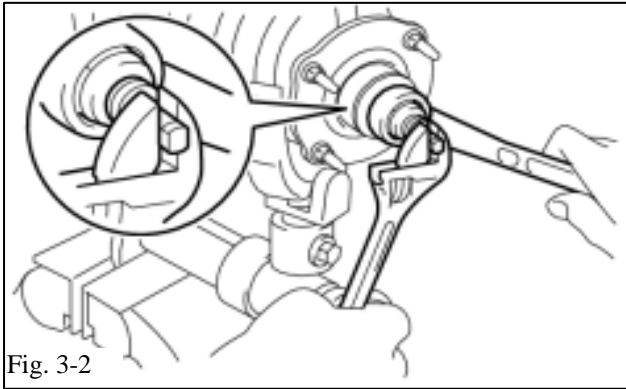

Fig. 3-2

- (3) Do not compress the coil spring more than necessary.
- (4) Do not use an impact wrench. It will damage SST.
- (5) Do not place yourself over the top of the shock absorber.

NOTE: Be careful as the coil spring may spring upward and cause an injury.

- (b) Remove the front support to front shock absorber nut and discard. (Fig. 3-2)
- (c) Remove the suspension support, 2 retainers and 2 cushions from the shock absorber rod and retain for reuse.
- (d) Discard the OE front spring and shock.
- (e) Repeat steps 3(a) – 3(d) for other OE spring/shock assembly.

4. Assemble TRD Front Springs and Shocks

- (a) Using the same spring compressor, install the TRD front coil spring. (Fig. 4-1)

- (1) Do not compress the coil spring more than necessary.
- (2) Do not use an impact wrench. It will damage SST.

- (b) Install the new TRD shock absorber and spring perch into the TRD coil spring.

- (1) Fit the lower end of the coil spring into the recess of the spring perch on the shock absorber. (Fig. 4-2)

- (c) From step 3(c), install the 2 cushions, 2 retainers and suspension support to the TRD piston rod.
- (d) Temporarily install a new top shock absorber nut (Top Nut PN: 90177-A0007)

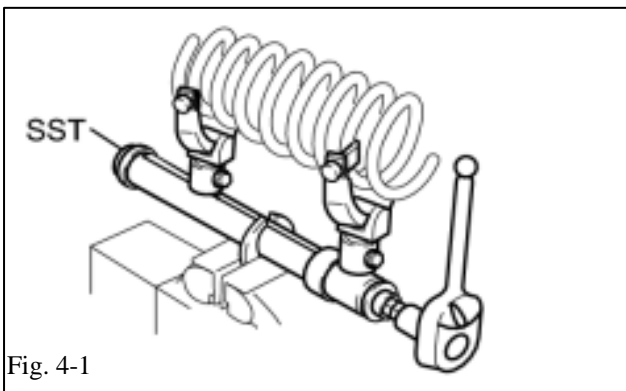

Fig. 4-1

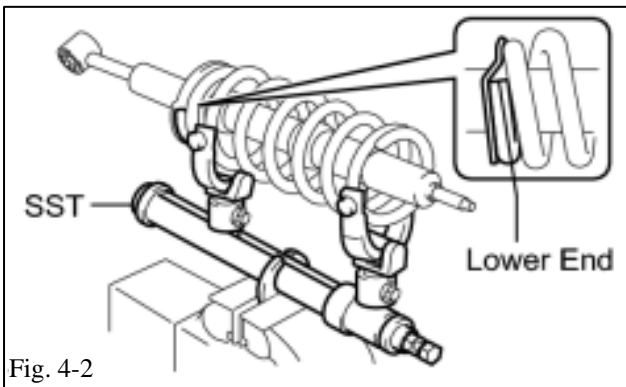
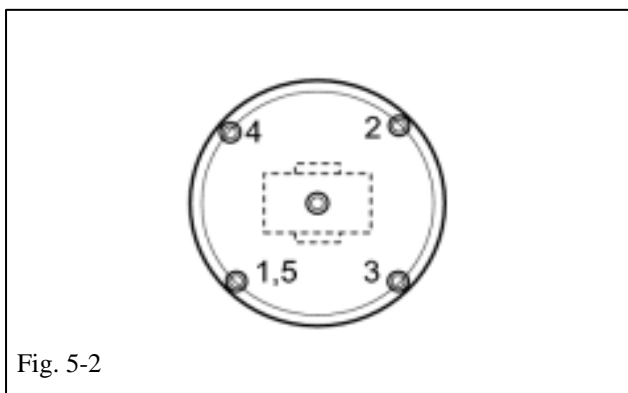
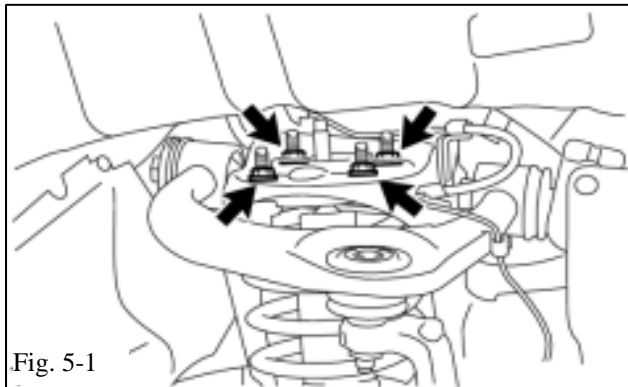
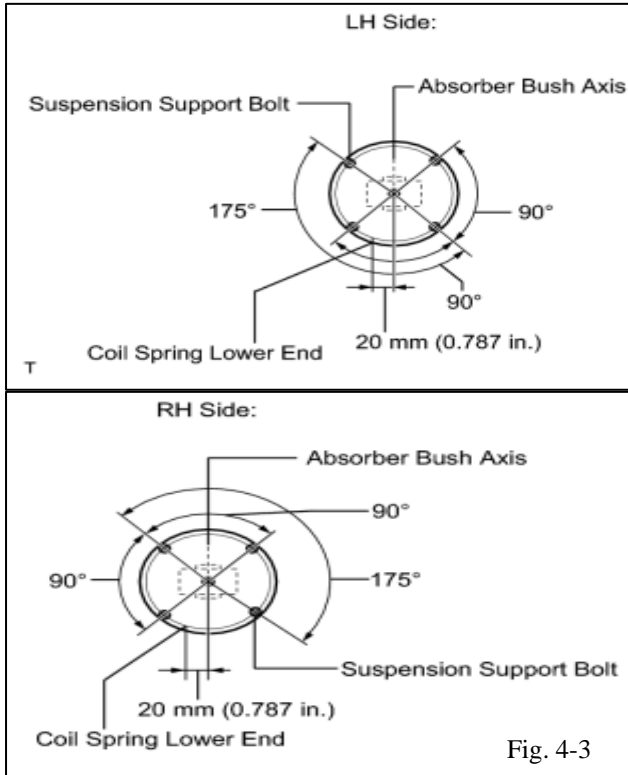

Fig. 4-2



- (e) Position the suspension support as shown. (Fig. 4-3)
- (f) Remove TRD coil spring/shock assembly from SST, while checking the position of the suspension support.
- (g) Tighten the new top nut to **25 N·m (255 kgf·cm, 18 ft·lbf)**.

(1) NOTE: Do not use an impact wrench. It will damage the shock absorber rod

- (h) Repeat steps 4(a) – 4(g) for other TRD spring/shock assembly.

5. Install TRD Front Springs and Shocks

- (a) Temporarily install the upper side of the shock absorber to the chassis frame with the 4 nuts. (Fig. 5-1)
- (b) Temporarily install the lower side of the shock absorber to the lower suspension arm with the bolt, washer and nut.
- (c) Repeat steps 5(a) – 5(b) on opposite side.
- (d) Install front wheels and securely tighten the lug nuts.
- (e) Lower the vehicle, and cycle the front suspension several times to stabilize the front suspension.
- (f) Re-raise the vehicle and remove the front wheels.
- (g) Tighten the bottom shock nut to **195 N·m (1988 kgf·cm, 144 ft·lbf)**.
- (h) Tighten the 4 upper nuts in diametrically opposite pairs to **45 N·m (459 kgf·cm, 33 ft·lbf)**. (Fig. 5-2)
- (i) Install front wheels, and torque to [Alloy-131 N·m (1336 kgf·cm, 97 ft·lbf)] OR [Steel -209 N·m (2130 kgf·cm, 154 ft·lbf)]

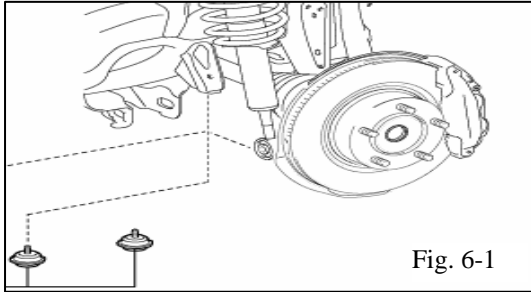

6. Install TRD Front Bump Stops

- (a) Remove and discard both OE spring bumpers (bump stops) and hardware from both lower control arms (remove 4 total).
- (b) Using the supplied front hardware kit, apply “RITE-LOC” to each of the 4 socket cap screws, and install the new TRD bump stops to both lower control arms (install 4 total) and torque to **43 N·m (442 kgf·cm, 32 ft·lbf)** (Fig. 6-1)

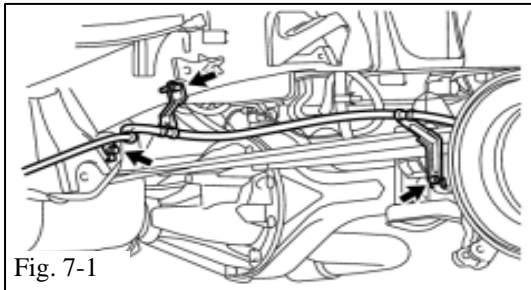

7. Removing OE Rear Leaf Springs & Shocks

- (a) Jack up and support the body on safety stands.
- (b) Lower the axle housing until the leaf spring tension is free, and keep it at this position.
- (c) Remove the spare tire
- (d) Remove both rear wheels
- (e) Disconnect the #3 parking brake cable assembly by removing the 3 bolts and disconnect the cable from the vehicle. (Fig. 7-1)
- (f) Support the rear axle housing with a jack using a wooden block to avoid damage. (Fig. 7-2)
- (g) Remove and save the OE lower shock bolt and nut, and disconnect the shock absorber lower side from the axle housing. (Fig. 7-3)
- (h) While holding the piston rod, remove and save the OE top nut, retainer, No. 1 cushion and discard OE shock absorber. (Fig. 7-4)
- (i) Remove the rear spring U-Bolt, by removing the 4 nuts, 4 washers and spring seat, then remove both U-Bolts. (Fig. 7-5)

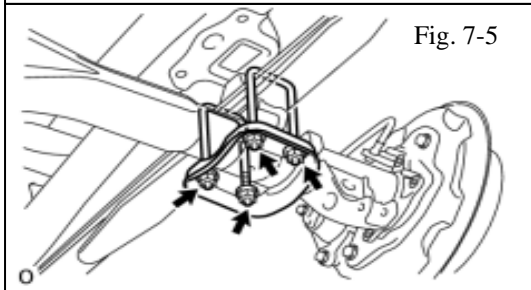
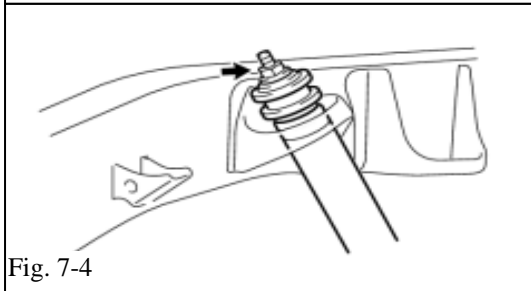
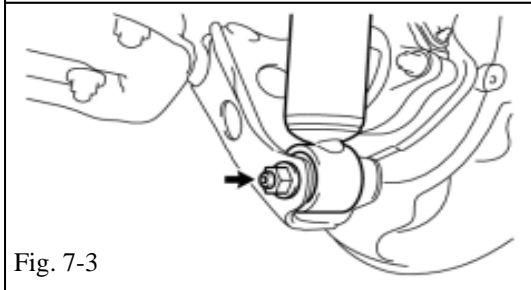
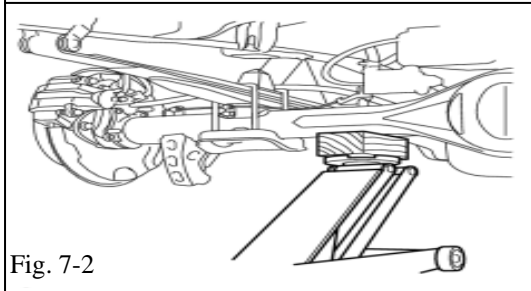

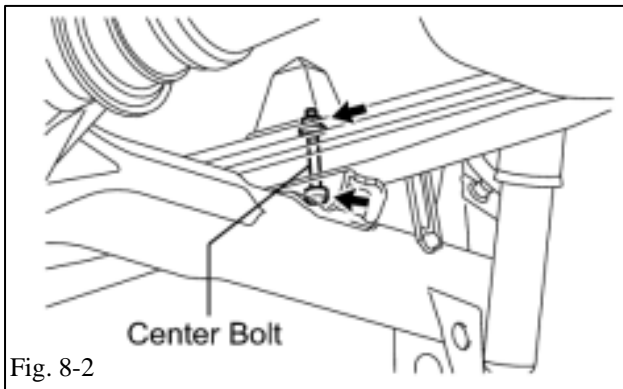
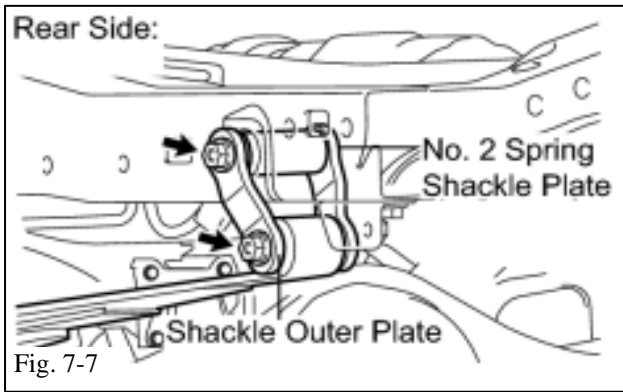
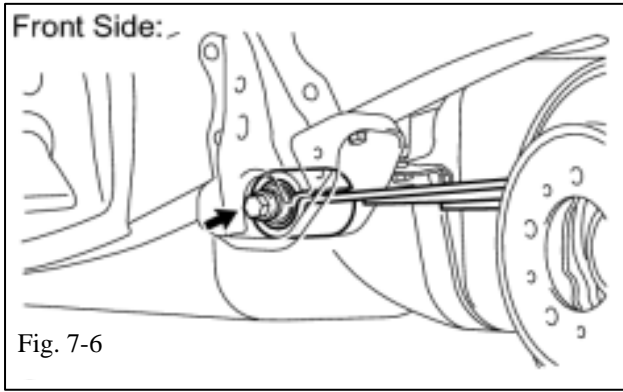

- (j) Remove and discard rear bump stop.
- (k) Remove the nut, washer and bolt from the front side of the OE leaf. (Fig. 7-6)
- (l) Remove and save the 2 nuts, 2 washers, shackle outer plate, No. 2 spring shackle plate and leaf spring from the rear side of the OE leaf. (Fig. 7-7)
- (m) Remove both shackle bushings from the frame and remove the OE rear leaf.
- (n) Repeat steps 7(g) – 7(m) on opposite side.

8. Installing TRD Rear Leaf Springs, Pinion Shims and Rear Shocks

- (a) Temporarily install the new TRD rear leaf spring with the OE No. 2 spring shackle plate, shackle outer plate, 2 washers and 2 nuts to the rear side (TRD Spring is symmetrical front/rear)(Fig. 7-7)
- (b) **FOR REGULAR-CAB ONLY:** Place the provided TRD pinion shim between the bottom of the TRD rear leaf spring and the top of the rear axle.
 - (1) Ensure that the shim is oriented with the high end of the shim pointing towards the front of the vehicle. (Fig. 8-1)
- (c) Temporarily install the new TRD rear leaf spring with the bolt, washer and nut to the front side. (Fig. 7-6)
- (d) Install the new TRD rear bump stop
 - (1) NOTE: Align the leaf spring center bolt and nut with the installation hole of the rear axle housing and TRD bump stop, so that they are not loose. (Fig. 8-2)

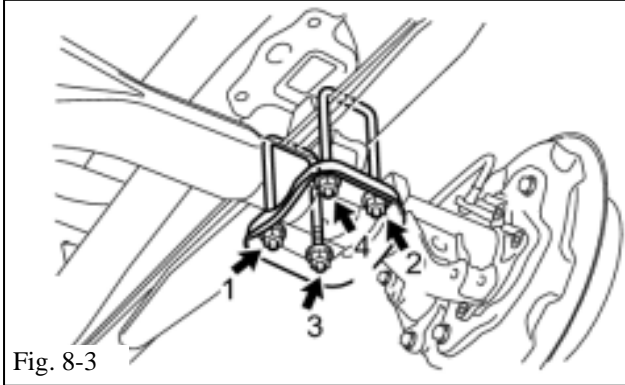

Fig. 8-3

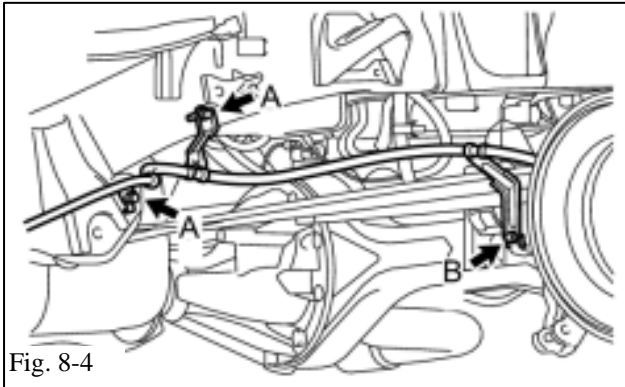
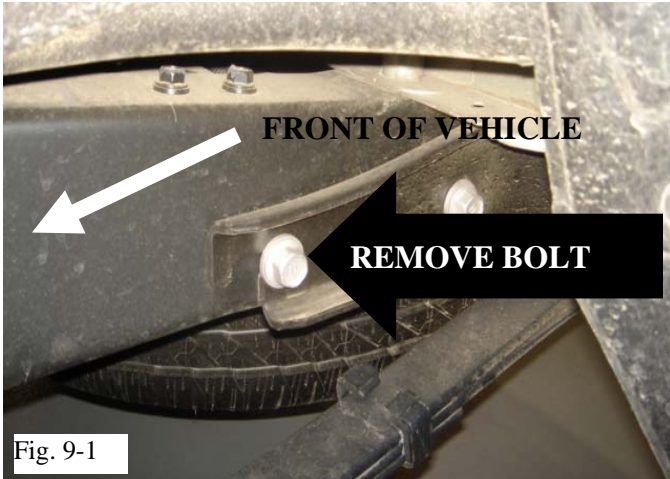

Fig. 8-4

- (e) Temporarily install the OE spring seat and 2 U bolts with the 4 washers and 4 nuts.
 - (1) Tighten the nuts in the order shown. (Fig. 8-3)
 - (2) Install the U bolts so that the lengths of the 4 ends under the spring seat are the same.
- (f) Connect the parking brake cable to the vehicle with the 3 bolts and torque to **19 N·m (194 kgf·cm, 14 ft·lbf)** (Fig. 8-4)
- (g) Install the OE top shock hardware (top cushion, retainer with the nut) onto the new TRD shock absorber and temporarily install onto vehicle. (Fig. 7-4)
- (h) Temporarily install the lower side of the new TRD shock absorber with the OE bolt and nut. (Fig. 7-3)
- (i) Repeat steps 8(a) – 8(h) on opposite side.
- (j) Install rear wheels & tighten the lug nuts.
- (k) Lower the vehicle, and cycle the rear suspension several times to stabilize the rear suspension.
- (l) Re-raise the vehicle and remove the rear wheels.
- (m) Torque the top shock nut to **28 N·m (286 kgf·cm, 21 ft·lbf)**
- (n) Torque the bottom shock nut to **90 N·m (918 kgf·cm, 66 ft·lbf)**
- (o) Torque the 3 nuts on each of the TRD rear leaf springs to **105 N·m (1071 kgf·cm, 77 ft·lbf)**
- (p) Torque the 4 nuts on each of the spring U-Bolts to **100 N·m (1020 kgf·cm, 74 ft·lbf)**
- (q) Install rear wheels, and torque to [Alloy-**131 N·m (1336 kgf·cm, 97 ft·lbf)**] OR [Steel -**209 N·m (2130 kgf·cm, 154 ft·lbf)**] .
- (r) Properly install spare tire.



9. Install TRD Rear Sway Bar Frame End Links – For Vehicles equipped with a Hitch

NOTE: BE SURE TO REFERENCE PANT BULLETIN #07-32 PRIOR TO INSTALLING THE REAR SWAY BAR, FOR HITCH CONFLICTS

(a) Using the 19mm socket, remove the forward most hitch frame bolt, and dispose. (Fig. 9-1)

 (b) Substitute previously removed frame bolt, with the M14x1.5x120 (22mm) bolt supplied in the hardware kit.

 (c) Install Frame End Link to weld nut into forward most frame rail, using the following hardware configuration: 22mm bolt, washer #1, end link, washer #2 & spacer. (Fig. 9-2)

(1) NOTE: Top of end link is the side that has the larger diameter.

(d) Repeat Steps 9(a) – 9(c) on opposite side.

10. Install TRD Rear Sway Bar Frame End Links – For Vehicles NOT equipped with a Hitch

 (a) Install Frame End Link to weld nut into forward most frame rail, using the following hardware configuration: 22mm bolt, washer #1, end link, washer #2, spacer & auxilliary washer.

(1) NOTE: Top of end link is the side that has the larger diameter.

(b) Repeat Step 10 (a) on opposite side.

11. Install TRD Rear Sway Bar onto End Links

(a) Starting on either side, mount the RSB onto both End Links using the following hardware configuration: 19mm bolt, washer #1, end link, RSB & 19mm nut - end links are mounted outboard of the RSB. (Fig. 10-1)

(1) Make sure RSB is mounted with the TRD sticker in the upright position.

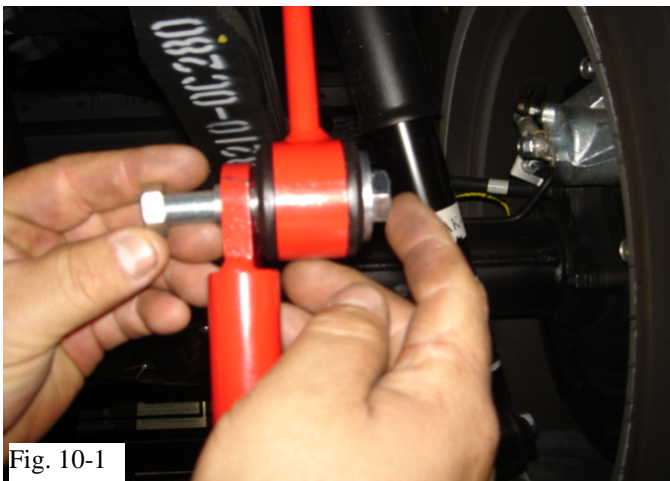

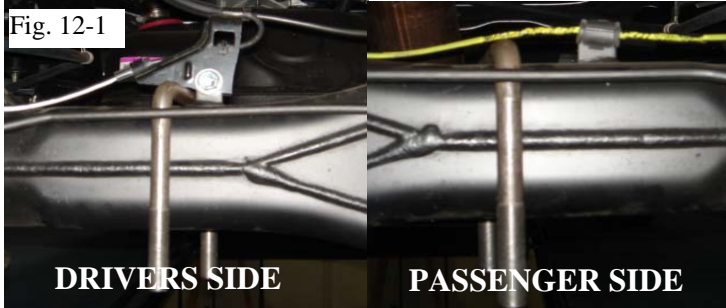

12. Install U-Bolts around Rear Axle

- (a) Starting on either side, slide both U-Bolts on top of rear axle, so that the threaded studs face down. LHS U-Bolt should be on the outside of brake bracket. RHS U-Bolt should be on the inside of brake bracket. (Fig. 12-1)

(1) NOTE: Ensure that the speed sensor wire and the brake tube do not get clamped between the u-bolt and the axle.

13. Install Bushings & Bushing Brackets

- (a) Apply the tube of the TRD supplied lube to the inside of each of the TRD bushings. Spread equally.
- (b) Slide the bushings over the TRD RSB.
- (c) Slide the bushing brackets over the bushings

14. Install RSB onto U-Bolts

- (a) Starting on either side, place the saddle brackets onto the U-Bolts, and slide the bushing brackets underneath. Secure the bushing brackets using the U-Bolt washers & nuts. (Fig 14-1)
- (b) Make sure the RSB is in a relaxed state and is centered relative to the vehicle. (Fig. 14-2)

15. Tighten all Hardware

- (a) Tighten both upper end link/frame bolts to 84 lbf.ft (+/- 12 lbf.ft)
- (b) Tighten both lower end link/RSB bolts to 48 lbf.ft (+/- 12 lbf.ft)
- (c) Alternate tightening the 4 U-Bolt/Bushing Bracket nuts from side to side, on each bracket, to a maximum of 48 lbf.ft – do not exceed.

|| 16. Install Door Jamb & Owners Manual Labels

17. Adjust 4 Wheel Alignment per Toyota Spec

