

Part Number: PTR04-35070

Kit Contents

Item #	Quantity Req'd.	Description
1	1	Lever assembly
2	1	Spacer assembly
3	1	Hardware bag
4	1	Installation instructions

Hardware Bag Contents

Item #	Quantity Req'd.	Description
1	4	8mm x 1.25 x 50mm long bolt

Additional Items Required For Installation

Item #	Quantity Req'd.	Description
1	1	FIPG #00295-01281

Conflicts

Note: None

Recommended Tools

Safety Tools	
Work gloves	
Eye protection	safety glasses
Special Tools	
Torque wrench: $\frac{3}{8}$ inch drive	25 lbs.-ft set range
Lock-ring pliers: MAC Tools P21A	or similar (optional)
Installation Tools	
12mm socket	$\frac{3}{8}$ " drive
$\frac{3}{8}$ inch drive ratchet	
3-inch extension	$\frac{3}{8}$ " drive
10mm socket	$\frac{1}{4}$ " drive
10-12 inch extension	$\frac{1}{4}$ " drive
$\frac{1}{4}$ inch drive ratchet	
Flat blade screwdriver	
Phillips screwdriver	#2
Plastic mallet	or other non-marring mallet
Gasket scraper	Snap-on CSA8B or similar
Special Chemicals	

Color Applicability/Trim Level

Accessory Color												
Vehicle/Trim Color												

General Applicability





Note: 2007- FJ Cruiser with RA-61f, 6-Spd. transmission

Recommended Sequence of Application

Item #	Accessory	
1	Spacer assembly	
2	Lever assembly	
3	Shift knob/s	

*Mandatory

Legend

	STOP: Damage to the vehicle may occur. Do not proceed until process has been complied with.
	OPERATOR SAFETY: Use caution to avoid risk of injury
	CRITICAL PROCESS: Proceed with caution to ensure a quality installation. These points will be audited on a completed vehicle installation
	GENERAL PROCESS: This highlights specific processes to ensure a quality installation. These points will be audited during the accessory installation
	TOOLS & EQUIPMENT: This calls out the specific tools and equipment required for this process

A. Check Kit Contents

1. Open box and inspect parts.

B. Vehicle Preparation

1. Cover front seats with blankets or plastic seat protectors.

C. Remove Shift Knobs

1. Remove factory shift knob by unscrewing knob counterclockwise. (Fig. C1)

2. Remove factory 4WD High-Low shift knob by unscrewing knob counterclockwise. (Fig. C2)

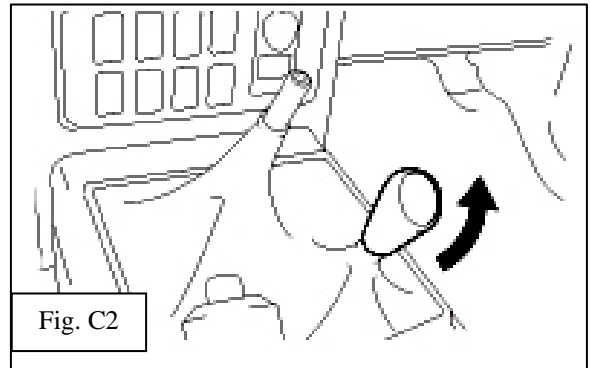
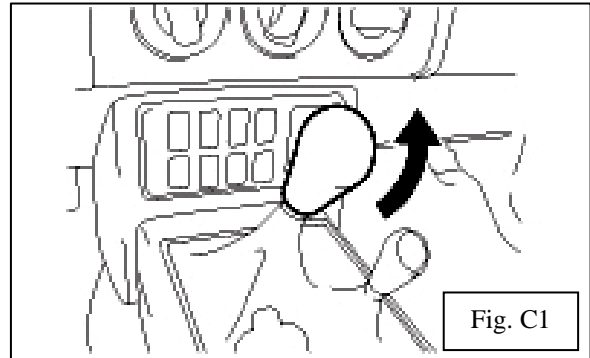

D. Remove Parking Brake Hole Cover Sub-Assy.

1. Disengage the 2 A claws and 2 B claws. (Fig D1)

2. Slide the parking brake hole cover toward the front of the vehicle, disengage the 2 C claws and remove the parking brake hole cover. (Fig. D1)

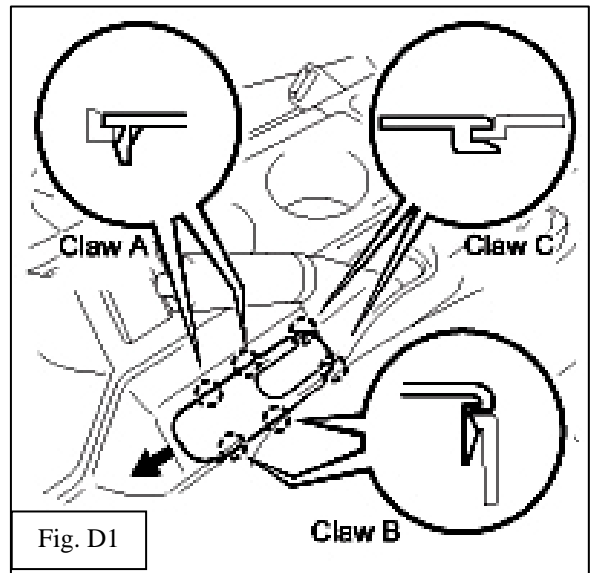

E. Remove Console Assembly

1. Remove console upper rear panel sub-assembly.
 - i. Shift the shift lever into N position.
 - ii. Disengage the 5 clips and 3 claws and remove the console upper rear panel sub-assembly. (Fig. E1)

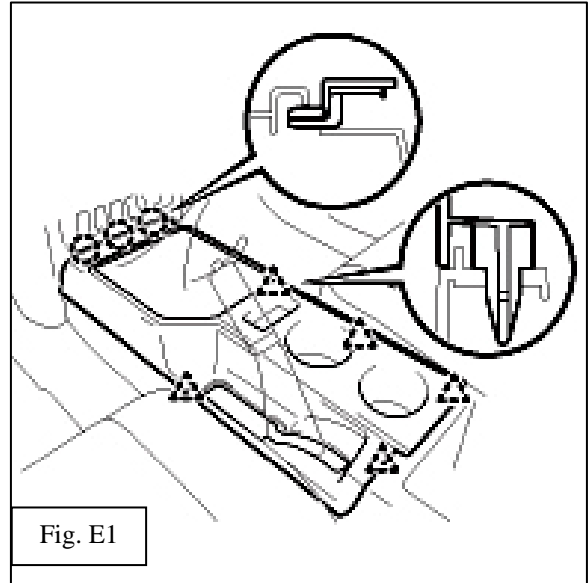

2. Remove the box bottom mat. (Fig. E2)

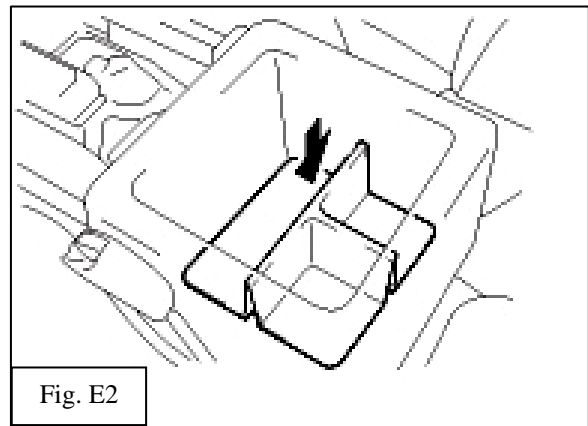

3. Remove front console box.
 - i. Remove the 4 bolts and save for re-use. (Fig E3)
 - ii. Disengage the 5 claws and remove console box. (Fig. E3)

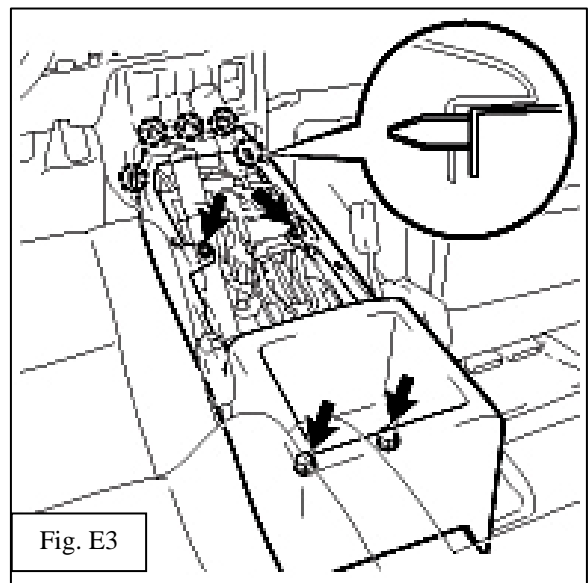

F. Remove Center Console Insulated Mat

1. Remove the insulated mat that fits around both shift levers. (Fig. F1)



Fig. F1

G. Remove Shift Lever Boot Assembly

1. Remove the rear 4 screws. (Fig. G1)
2. Remove front 2 clips by depressing the center pin down with a small screwdriver, and then lift the shift lever boot flange up to disengage the clips. Save clips and screws for re-use. (Fig. G1)

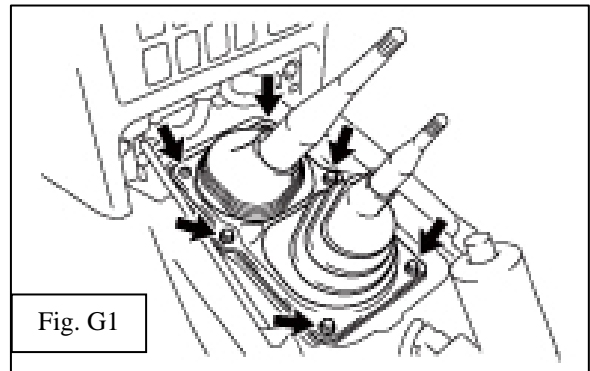

Fig. G1

H. Remove Shift Lever Assembly

1. Separate the shift lever cap boot from the shift lever retainer. (Fig H1)

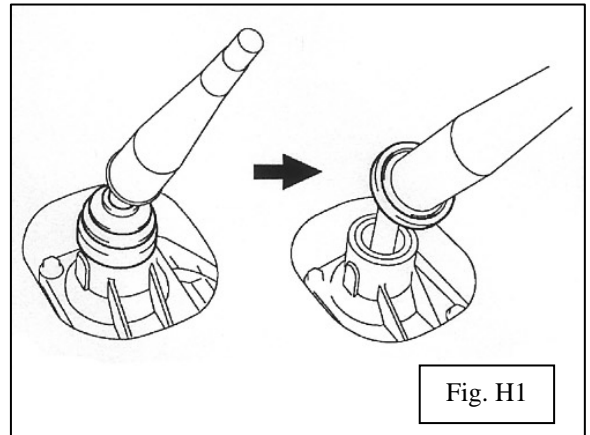

Fig. H1

- ➔ 2. Cover the shift lever cap with a cloth. Press down on the shift lever cap, and turn it counter clock-wise to remove the shift lever. (Fig. H2)

Note: MAC Tools P21A lock-ring pliers (or similar) may be used to locate on the flats of the shift lever cap to assist in turning counterclockwise. Use a flat blade screwdriver to press down on the shift lever cap while turning.

I. Remove Shift Lever Retainer

- ➔ 1. Remove the 4 bolts that secure the shift lever retainer to the transmission. (Fig. I1)

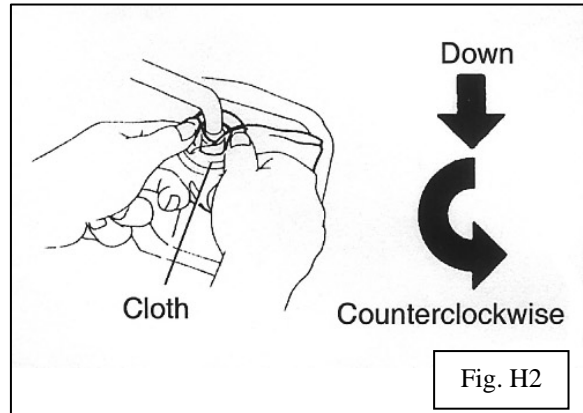

Fig. H2

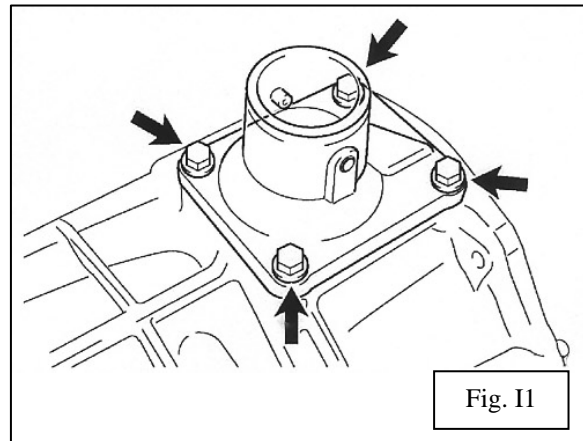

Fig. I1

- ⚠ 2. If necessary, use a plastic head hammer to tap the shift lever retainer to remove it from the transmission. (Fig I2)

Caution: Two alignment dowels are used to align shift lever retainer to transmission case. Dowels should remain in transmission case. If one or both dowels stay in shift lever retainer, then remove them and re-install in transmission case.

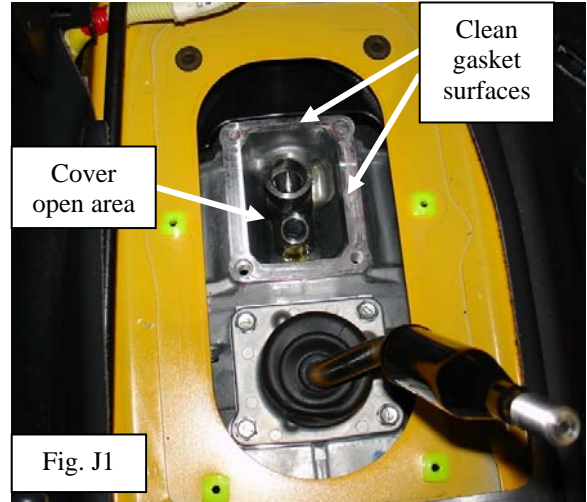

Fig. I2

J. Clean Gasket Surfaces

1. Clean shift lever retainer and transmission gasket surfaces. A gasket scraper may be used. (Fig. J1)

Caution: Place a clean shop cloth over the open shift retainer area to keep gasket material out.



K. Apply FIPG Sealant (All)

- ➔ 1. Apply FIPG sealant to the lower-side (“LWR” mark) of the supplied spacer. (Fig. K1) The lower-side also contains two counter-bores to locate on the dowels in the transmission case.

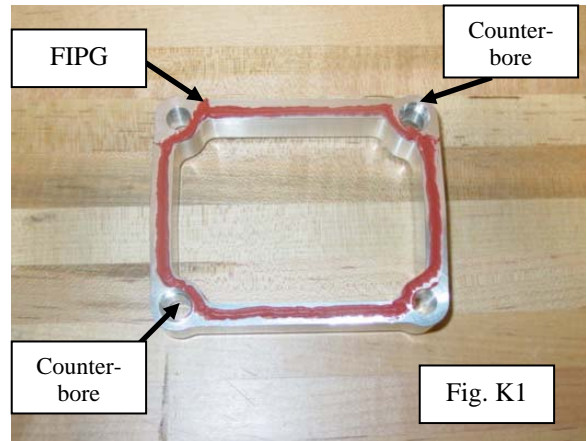

- ➔ 2. Apply FIPG sealant to the shift lever retainer. (Fig. K2)

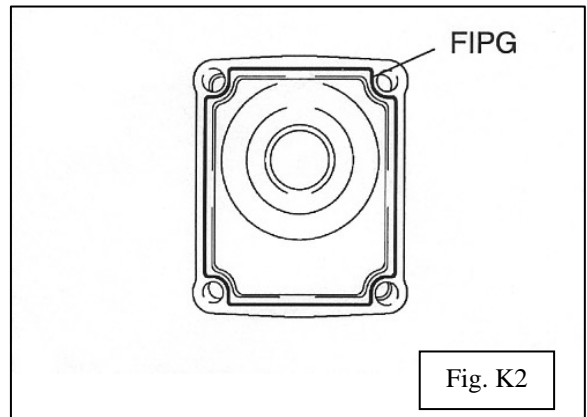

L. Install Spacer and Shift Lever Retainer

- ➔ 1. Install spacer onto transmission. Make sure dowels engage correct larger counter-bored holes. (Fig L1)



Fig. L1

- ➔ 2. Install shift lever retainer on to spacer. Again, make sure dowels engage correct larger counter-bored holes.
- ⚠ 3. Install 4 supplied 50mm long bolts. Tighten bolts using a star pattern. (Fig. L2) Torque bolts to 25 lbs.-ft.

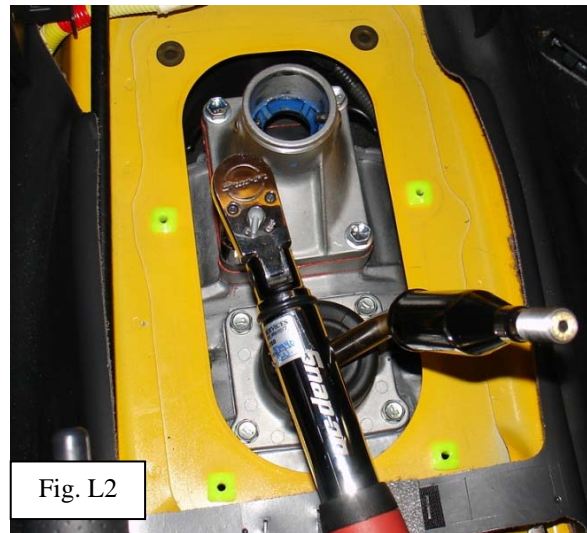

Fig. L2

M. Install TRD Shift Lever Assembly

- 1. Install TRD shifter lever assembly by following the reverse procedures from Step H2, then Step H1.

N. Check Gearshift Engagement

- ⚠ 1. Install original equipment (OE) shift knob and validate access to all gears, including reverse.
- 2. Remove OE shift knob when done.

O. Install Shift Lever Boot Assembly

1. Use the reverse procedure from Steps G2 and G1 to install shift lever boot assembly.

P. Re-install Insulated Mat

1. Re-install insulated mat around shift levers by using the reverse procedure from Step F1.

Q. Re-install Console Box Assembly

1. Re-install console box assembly by using the reverse procedures from Steps E3, E2, and E1.

R. Re-install Parking Brake Hole Cover Sub-Assy.

1. Re-install parking brake hole cover sub-assembly by using the reverse procedure from Steps D2, and D1.

S. Install Shift Knob/s



1. Install TRD shift knob/s onto shift lever/s so gearshift pattern/s are in correct position. Use PPO instructions in PPO Instruction Database for proper installation of TRD shift knob/s.

Care and Maintenance

- Your TRD Quickshifter has a painted finish and needs no special cleaning or maintenance. The shift lever is covered by the factory rubber boot and also the leather boot attached to the console box front.



Section III – Functional Verifications

Check: _____

- Shifter function

- Shift knob/s

Look For: _____

- Gear engagement in all six gears and reverse.

- Correct shift knob clocking