

**Part Number: PT938-42130-XX**

**Kit Contents**

| Item # | Quantity Reqd. | Description            |
|--------|----------------|------------------------|
| 1      | 1              | Molding, LH Front Door |
| 2      | 1              | Molding, LH Rear Door  |
| 3      | 1              | Molding, RH Front Door |
| 4      | 1              | Molding, RH Rear Door  |

**Hardware Bag Contents**

| Item # | Quantity Reqd. | Description |
|--------|----------------|-------------|
| 1      |                |             |
| 2      |                |             |

**Additional Items Required For Installation**

| Item # | Quantity Reqd. | Description |
|--------|----------------|-------------|
| 1      |                |             |
| 2      |                |             |

**Conflicts**

|      |
|------|
| None |
|------|

**Recommended Tools**

|  |   |
|--|---|
| <b>Personal &amp; Vehicle Protection</b> | <b>Notes</b>                            |
| Safety Glasses                           |   |
| Vehicle Protection                       | Seat & Floor Covers                     |
|  |   |
| <b>Special Tools</b>                     | <b>Notes</b>                            |
| Roller                                   | Hard Rubber Hand Roller, 1" to 3" wide. |
| <b>Installation Tools</b>                | <b>Notes</b>                            |
| Flexible Scale or Tape Measure           |   |
| Masking Tape                             | 1-2" wide                               |
| Clean Lint-free Cloths                   |   |
| Non intrusive Infrared Temp Probe/Gun    |   |
| Non-marring straight edge                |   |
| Heat Gun                                 |   |
| <b>Special Chemicals</b>                 | <b>Notes</b>                            |
| Cleaner                                  | 3M™ Prep Solvent-70                     |

**General Applicability**

|   |
|---|
| Body Side Molding can be installed on all RAV4 models |
|---|

**Recommended Sequence of Application**







| Item # | Accessory   |
|--------|---|
| 1      | Body Side Molding – Can be installed in any sequence with other accessories |
| 2      | Door Edge Guard   |

\*Mandatory

**Vehicle Service Parts** (may be required for reassembly)

| Item # | Quantity Reqd. | Description |
|--------|----------------|-------------|
|        |                |             |
|        |                |             |

**Legend**

|   |  |
|---|--|
|    | <b>STOP:</b> Damage to the vehicle may occur. Do not proceed until process has been complied with.   |
|    | <b>OPERATOR SAFETY:</b> Use caution to avoid risk of injury.   |
|    | <b>CAUTION:</b> A process that must be carefully observed in order to reduce the risk of damage to the accessory/vehicle and to ensure a quality installation. |
|   | <b>TOOLS &amp; EQUIPMENT:</b> Used in Figures calls out the specific tools and equipment recommended for this process.   |
|  | <b>REVISION MARK:</b> This mark highlights a change in installation with respect to previous issue.  |
|  | <b>SAFETY TORQUE:</b> This mark indicates that torque is related to safety.  |

Care must be taken when installing this accessory to ensure damage does not occur to the vehicle. The installation of this accessory should follow approved guidelines to ensure a quality installation.

These guidelines can be found in the "Accessory Installation Practices" document.

This document covers such items as:

- Vehicle Protection (use of covers and blankets, cleaning chemicals, etc.).
- Safety (eye protection, rechecking torque procedure, etc.).
- Vehicle Disassembly/Reassembly (panel removal, part storage, etc.).
- Electrical Component Disassembly/Reassembly (battery disconnection, connector removal, etc.).

Please see your Toyota dealer for a copy of this document.

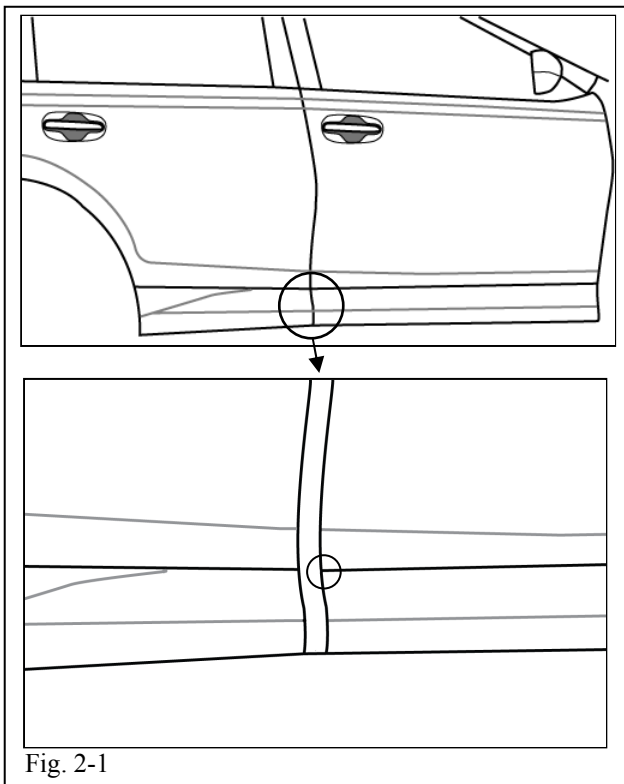
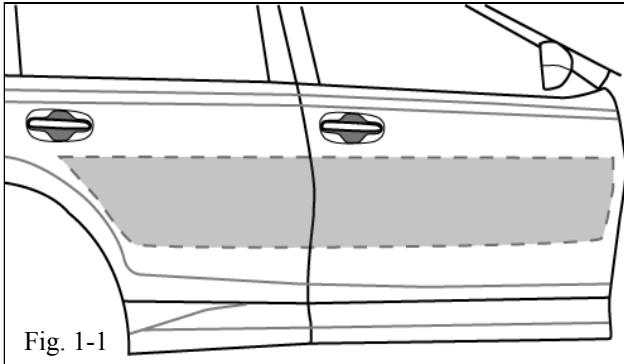

### 1. Vehicle Preparation

- STOP** (a) Before working on the vehicle, protect the seats and carpets with covers.
- STOP** (b) The work area, body side moldings, and vehicle door surface temperature must be between 60°F and 110 °F.
- (c) Saturate a clean lint-free cloth with 3M™ Prep Solvent-70 and clean the areas of each door as shown in (Fig. 1-1).
  - (1) When cleaning with 3M™ Prep Solvent-70 follow the manufacturer's directions. Do not allow cleaner to air dry.
- (d) Wipe the cleaned surfaces with a clean, dry, lint-free cloth.

**NOTE:** Once cleaned do not contaminate this surface by touching it with your bare hands.

### 2. Positioning Tape Application

- !** (a) Locate the top most point on the rear edge of the front door cladding. (Fig. 2-1). All horizontal measurements will be provided from this location.

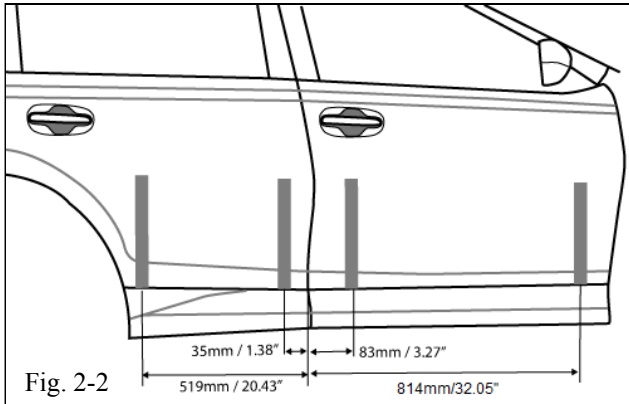

- ⚠ (b) Measure 83mm forward and place a vertical piece of tape on the front door approximately 350mm long. Measure 814mm forward and place a vertical piece of tape on the front door approximately 350mm long. Measure 35mm rearward and place a vertical piece of tape on the rear door approximately 350mm long. Measure 519mm rearward and place a 350mm vertical piece of tape on the rear door. See (Fig 2-2).

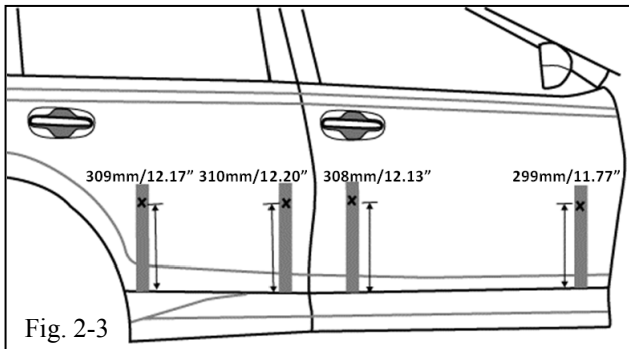

- ⚠ (c) Mark the vertical pieces of tape as shown (Fig. 2-3). Measurements are taken from the top most edge of the door cladding.

- ⚠ (d) Apply a strip of tape along the length of the doors as shown in Fig. 2-4 connecting the marks on the vertical pieces of tape. Make certain that the top edge of the tape aligns with the marks on the vertical pieces of tape.

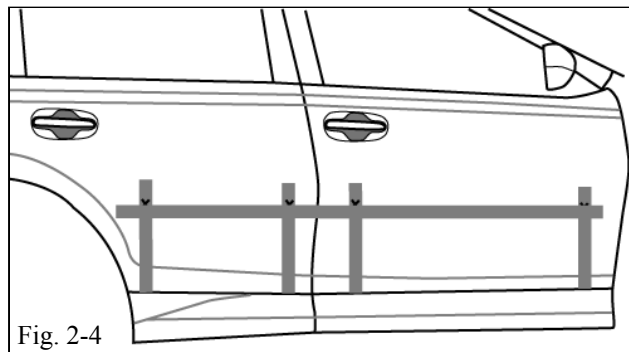

- ⚠ (e) Trim any length of vertical tape protruding beyond the tape installed in step (d) as shown in (Fig 2-5).

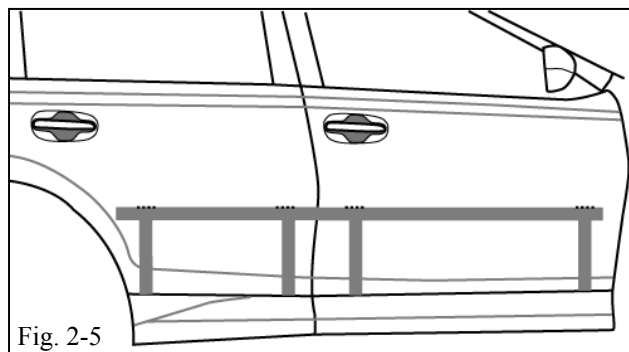

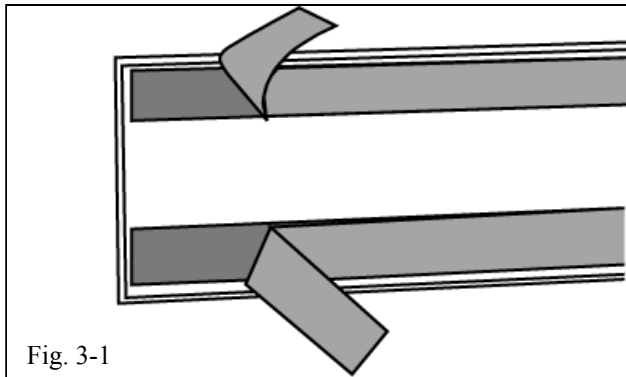

Fig. 3-1

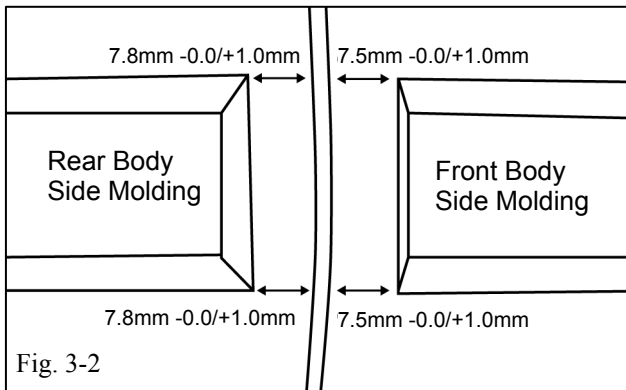

Fig. 3-2

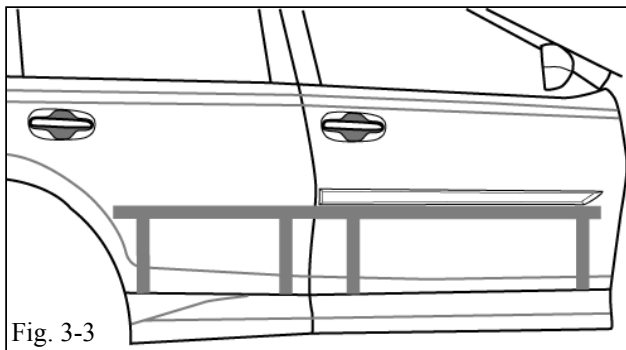
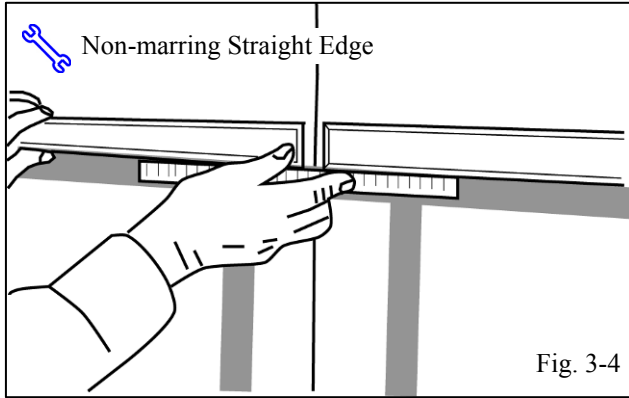

Fig. 3-3

### 3. Body Side Molding Installation.

- (a) On the inside of each of the four moldings is identified as to their correct position on the vehicle. While carefully holding the molding by its edges, fold the tape tabs on the horizontal tape lengths upwards (top piece) and downwards (bottom piece) (Fig 3-1) such that the tabs are accessible when the molding is in install position.
- (b) Start with either front door using the appropriate front molding (longer molding).
- ⚠ (c) The opening between the doors should look like Fig. 3-2. Tolerance for flushness in the vertical direction of the front and rear molding in relation to each other is 0.0mm +/- 1.0mm.
- ⚠ (d) Place the rear edge of the front molding **7.5mm** from the rear edge of the front door (Fig 3-2). Ensure that the 7.5mm minimum distance is carefully measured.
- (e) Align the bottom of the molding flush with the top edge of the tape spanning the doors. (Fig 3-3)
- (f) Re-position as required before sticking the tape to the door.
- ⚠ (g) Once properly aligned, carefully expose the tape by peeling away the liner beginning with the tape at the rear of the molding and working forward.
- (h) Repeat for the front body side molding on the other side of the vehicle.
- (i) Proceed to either rear door using the appropriate molding (shorter molding).
- ⚠ (j) Place the front edge of the rear molding **7.8mm** from the front edge of the rear door (Fig 3-2). Ensure that a minimum 7.8mm distance is maintained.



(k) Place a non-marring straight edge flush with the bottom of the front molding. Then set the front edge of the rear molding on top of the straight edge. Align the rear edge with the tape. (Fig 3-4).



(l) Once properly aligned, carefully expose the tape by peeling away the liner beginning with the tape at the front of the molding and working rearward.

(m) Repeat on opposite side of vehicle.



(n) Using the hand roller and a clean rag, roll around the perimeter of the parts with a firm pressure to ensure complete adhesion of the acrylic foam tape to the door surfaces. (Fig. 3-5)

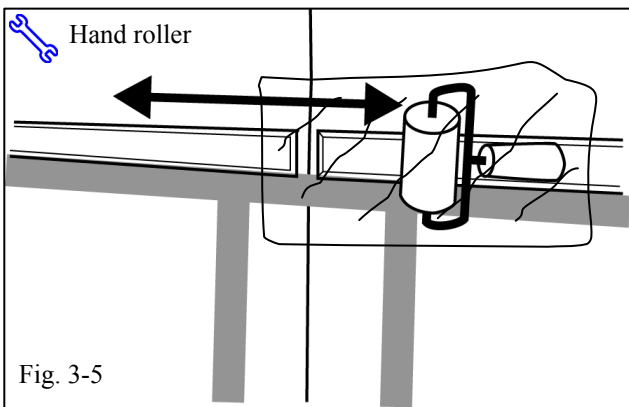

(o) Remove and discard all tape strips (Fig 3-6).

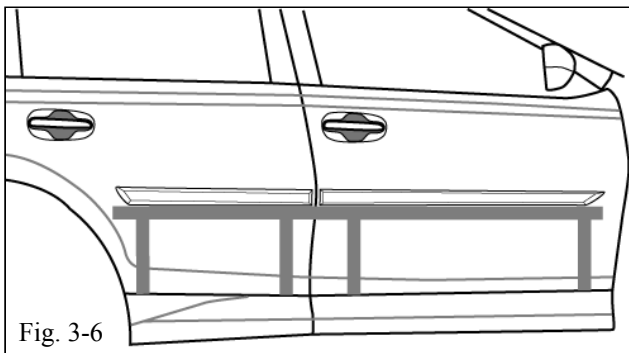

Checklist - these points **MUST** be checked to ensure a quality installation.

Check:

Accessory Function Checks

Check visual alignment

Check for proper tape adhesion.

Look For:

The moldings should be visually straight.  
The front edge of the rear moldings should be 7.8 mm away from the front edge of the rear door.

The rear edge of the front moldings should be 7.5 mm away from the rear edge of the front doors.

Confirm 100% tape adhesion completely around the part between the Body Side Molding and door sheet metal.

No gap is allowed between the tape and the vehicle door surfaces, except where the tape seam joints on the backside.

Vehicle Function Checks

None Required

Vehicle Appearance Check

After accessory installation and removal of protective cover(s), perform a visual inspection.

Ensure no damage (including scuffs and scratches) was caused during the installation process.

(For PPO installations, refer to TMS Accessory Quality Shipping Standard.)