

Preparation

Part Number: PT932-89100

NOTE: Part number of this accessory may not be the same as the part number shown.

Kit Contents

Item #	Quantity Reqd.	Description
1	1	Stainless Steel Exhaust Tip
2	1	Stainless Steel Clamp Assembly
3	2	Stainless Steel Spacers
4	1	Installation Instructions

Vehicle Service Parts (may be required for reassembly)

Item #	Quantity Reqd.	Description
1		
2		
3		

Hardware Bag Contents

Item #	Quantity Reqd.	Description
None		

Additional Items Required For Installation

Item #	Quantity Reqd.	Description
None		

Conflicts

--

Recommended Tools

Personal & Vehicle Protection	Notes
None	
Special Tools	Notes
None	
Installation Tools	Notes
Ratchet	
Socket	15 mm Deep well Socket
Torque wrench	55 N-m
Non-scratch cloth	
Special Chemicals	Notes
Glass Cleaner	Dealer installed
Approved Cleaner	VDC installed

General Applicability

--

Recommended Sequence of Application

Item #	Accessory
1	Exhaust tip
2	
3	

*Mandatory

Legend

 **STOP:** Damage to the vehicle may occur. Do not proceed until process has been complied with.

 **OPERATOR SAFETY:** Use caution to avoid risk of injury.

 **CAUTION:** A process that must be carefully observed in order to reduce the risk of damage to the accessory/vehicle and to ensure a quality installation.

 **TOOLS & EQUIPMENT:** Used in Figures calls out the specific tools and equipment recommended for this process.

 **REVISION MARK:** This mark highlights a change in installation with respect to previous issue. **SAFETY**

 **TORQUE:** This mark indicates that torque is related to safety.

Procedure

Care must be taken when installing this accessory to ensure damage does not occur to the vehicle. The installation of this accessory should follow approved guidelines to ensure a quality installation.

These guidelines can be found in the "Accessory Installation Practices" document.

This document covers such items as:-

- Vehicle Protection (use of covers and blankets, cleaning chemicals, etc.).
- Safety (eye protection, rechecking torque procedure, etc.).
- Vehicle Disassembly/Reassembly (panel removal, part storage, etc.).
- Electrical Component Disassembly/Reassembly (battery disconnection, connector removal, etc.).

Please see your Toyota dealer for a copy of this document.

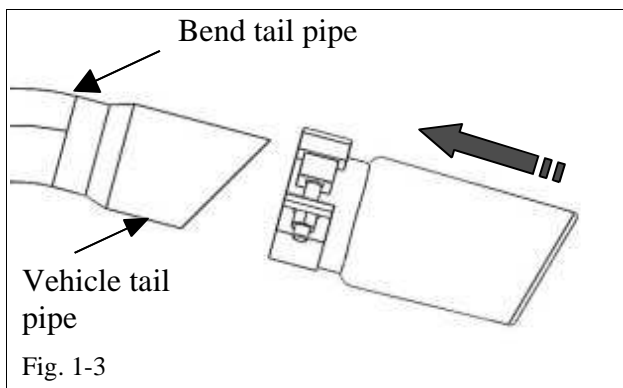
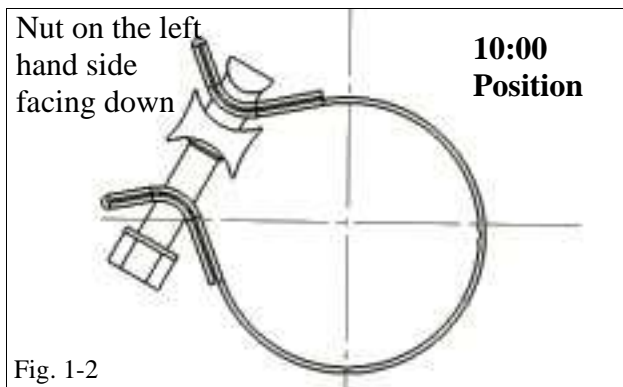
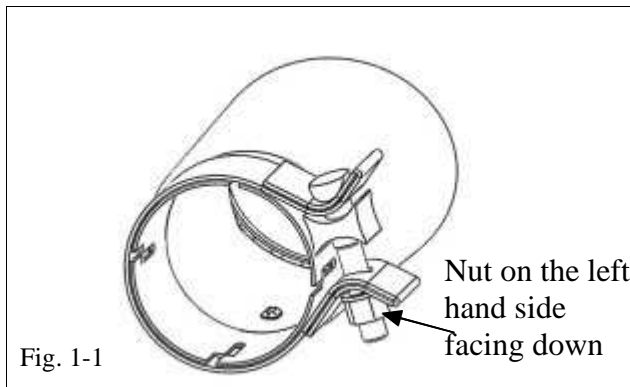
Installation.

- (a) Make sure the vehicle's tail pipe is free from dirt and debris.
- (b) Remove exhaust tip from box and set on a soft surface to prevent scratching.
- (c) Slide the Stainless Steel Clamp over the exhaust tip inlet as shown. (Fig. 1-1)
 - ⚠ (1) Locate the bolt of the clamp at the left side (driver side) of the exhaust tip inlet with the nut facing down as shown. (Fig. 1-1 & 1-2).
 - ⚠ (2) Slide the exhaust tip and clamp assembly over the tail pipe until the edge of the exhaust tip is on the beginning of the bend of vehicle's tail pipe. (Fig. 1-3)
 - (1) The exhaust tip should be oriented with the internal bump on down.
 - ⚠ (2) Slide the exhaust tip until the internal bump interferes with tail pipe, approximately 73mm distance between the end of tail pipe and end to the exhaust tip as shown. (Fig. 1-4)
- (e) Install the Stainless Steel spacers.
 - (1) Make sure that the clamp assembly is loose enough to move around the exhaust tip.
 - ⚠ (2) Slide the two spacers into exhaust tip opening between the tail pipe and exhaust tip inlet. Place one at left and the other at right.(Fig. 1-5)
 - ⚠ (3) Make sure the edges of the spacers are flush to the tip's edges.

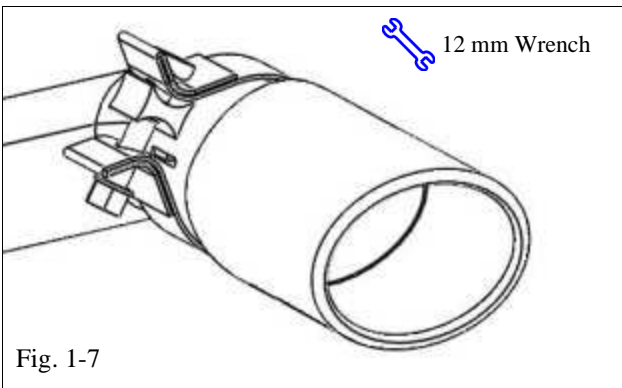
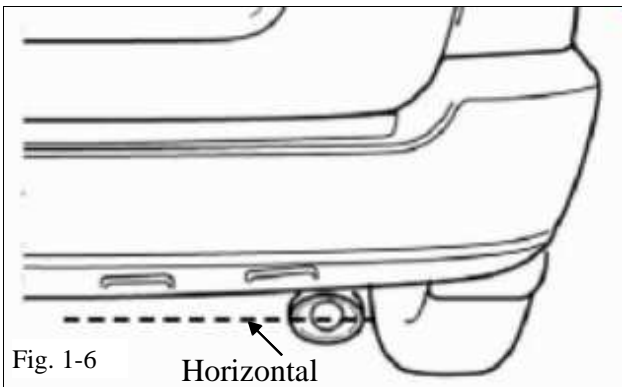
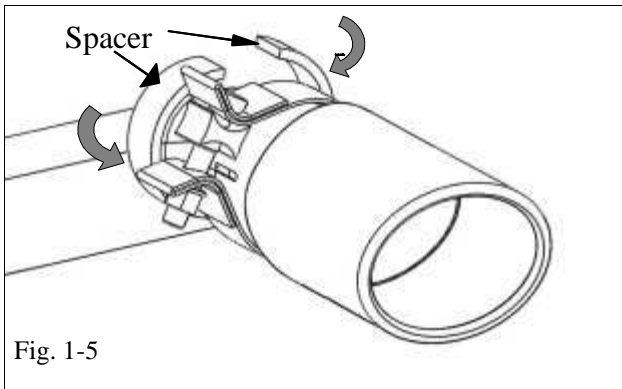
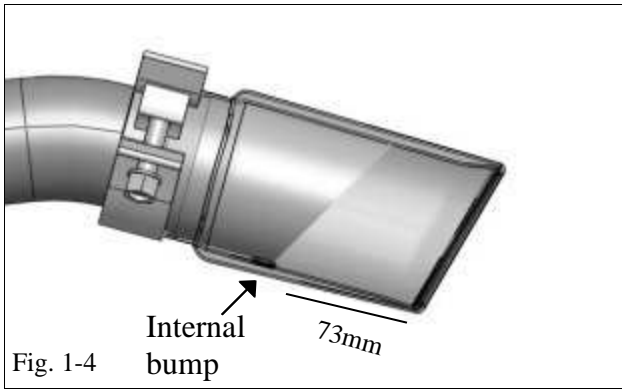

- (f) Align the exhaust tip so that the oval is horizontal to the rear of bumper fascia. (Fig. 1-6)
- (g) Once the tip is positioned correctly and the alignment seems accurate, tighten the clamp nut making sure the clamp remains in the proper position.
-  (h) Torque clamp nut to $55\text{Nm} \pm 8\text{Nm}$ ($40.57\text{ Ft/lbs} \pm 5.9\text{ Ft/lbs}$). (Fig. 1-7).
- (i) Clean exhaust tip with glass cleaner or approved cleaner and non-scratching cloth.

TOYOTA 4 RUNNER 2010 - STAINLESS STEEL EXHAUST TIP

Checklist - these points **MUST** be checked to ensure a quality installation.

Check:

Look For:

Accessory Function Checks

Verify part number on package.
Nut torque should be: 55Nm ± 8Nm (40.57 Ft/lbs ± 5.9 Ft/lbs).
Clamp should be oriented with bolt on the left side with the nut facing down.
Tip oval should be horizontal to rear bumper fascia.

Correct part number has been installed.

 Nut torque.

Clamp alignment.

Tip alignment.

Vehicle Function Checks

Start engine and check for rattle or vibration of exhaust tip.

Rattle or vibration