

**Part Number: PT932-35160 (D-Cab)  
PT932-35161 (C-Cab)**

**Kit Contents**

Item #	Quantity Req'd.	Description
1	1	Step Bar – Driver Side
2	1	Step Bar – Passenger Side
3	2	Front mounting bracket
4	4	Middle/Rear mounting bracket

**Hardware Bag Contents**

Item #	Quantity Req'd.	Description
1	24	M8 x 25mm Hex head bolt
2	24	M8 Flat washer
3	24	M8 Lock washer

**Additional Items Required For Installation**

Item #	Quantity Req'd.	Description
1		
2		
3		

**Conflicts**

Regular/Access Cab Models
---------------------------

**Recommended Tools**

<b>Personal &amp; Vehicle Protection</b>	<b>Notes</b>
Safety glasses	
Safety gloves	(Optional)
<b>Special Tools</b>	<b>Notes</b>
None	
<b>Installation Tools</b>	<b>Notes</b>
Ratchet	
Socket	13mm
Extension	
Torque Wrench	0-50 N-m (0-37 ft-lbf )
Panel Pry Tool	Toyota SST 00002-06001-01
<b>Special Chemicals</b>	<b>Notes</b>
None	

**General Applicability**

D-Cab & C-Cab Models
----------------------

**Recommended Sequence of Application**

Item #	Accessory
1	
2	

\*Mandatory

**Vehicle Service Parts** (may be required for reassembly)

Item #	Quantity Req'd.	Description
1		
2		
3		

**Legend**

 **STOP:** Damage to the vehicle may occur. Do not proceed until process has been complied with.

 **OPERATOR SAFETY:** Use caution to avoid risk of injury.

 **CAUTION:** A process that must be carefully observed in order to reduce the risk of damage to the accessory/vehicle and to ensure a quality installation.

 **TOOLS & EQUIPMENT:** Used in Figures calls out the specific tools and equipment recommended for this process.

 **REVISION MARK:** This mark highlights a change in installation with respect to previous issue.

 **SAFETY TORQUE:** This mark indicates that torque is related to safety.

## Procedure

Care must be taken when installing this accessory to ensure damage does not occur to the vehicle. The installation of this accessory should follow approved guidelines to ensure a quality installation.

These guidelines can be found in the "Accessory Installation Practices" document.

This document covers such items as:-

- Vehicle Protection (use of covers and blankets, cleaning chemicals, etc.).
- Safety (eye protection, rechecking torque procedure, etc.).
- Vehicle Disassembly/Reassembly (panel removal, part storage, etc.).
- Electrical Component Disassembly/Reassembly (battery disconnection, connector removal, etc.).

Please see your Toyota dealer for a copy of this document.

### 1. Prepare for the Install.

- (a) Remove the contents from the box and verify that all parts are present and check for any damage.
- (b) See Fig. 1-1 to identify the brackets and their placement.

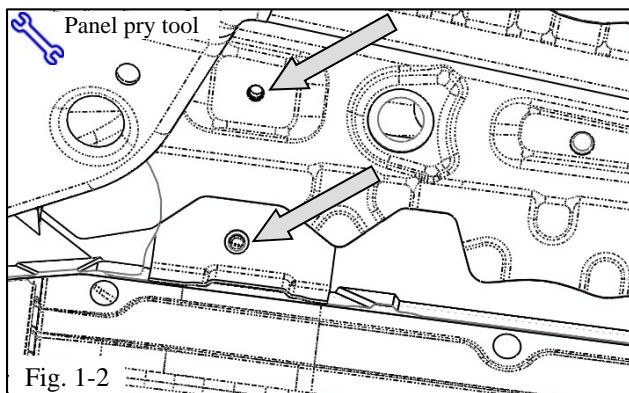
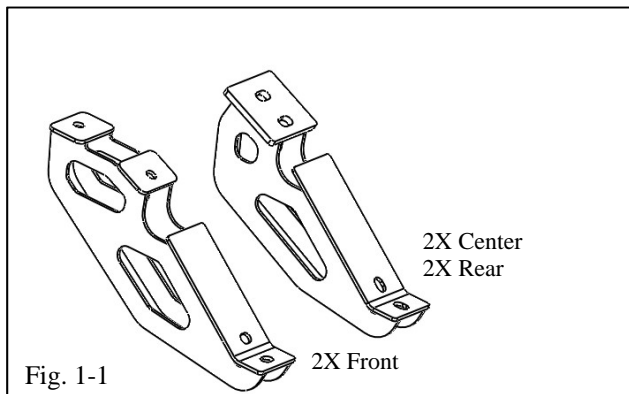

- (c) The front passenger side bracket mounting location is under the floorboard behind the front tire. Remove & discard the plastic screws from the mounting location (Fig. 1-2).

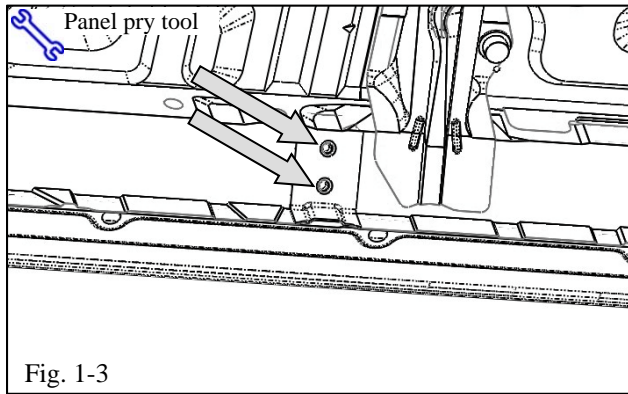

- (d) Remove & discard the plastic screws (4 total) from the middle and rear bracket mounting locations (Fig. 1-3).

## 2. Install the Passenger Side Tube Step.

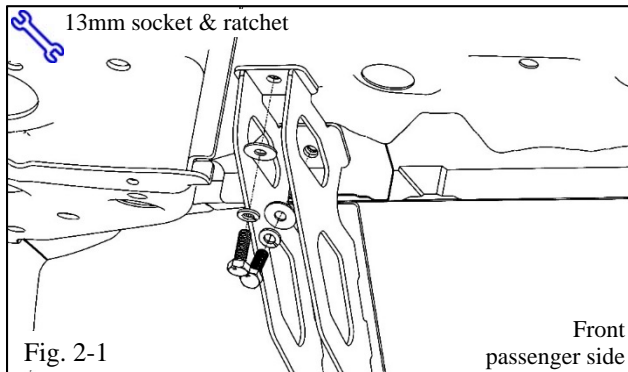

- (a) Use the supplied M8 hex head bolts, flat washers and lock washers to loosely attach the front passenger side mounting bracket to the vehicle (Fig. 2-1).

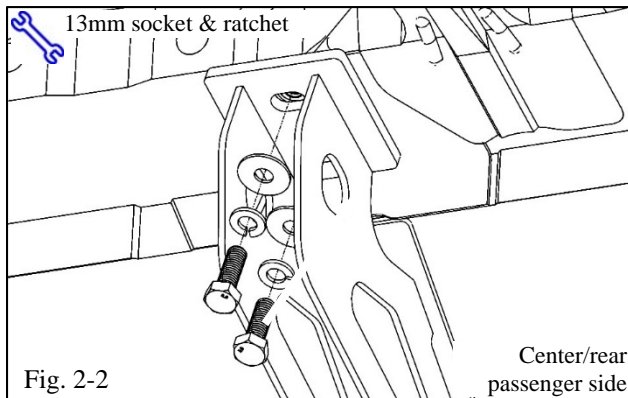

- (b) Use the supplied M8 hex head bolts, flat washers and lock washers to loosely attach the middle and rear passenger side mounting brackets to the vehicle (Fig. 2-2).

**⚠ NOTE:** The sealant must be removed out of the way of the middle bracket.

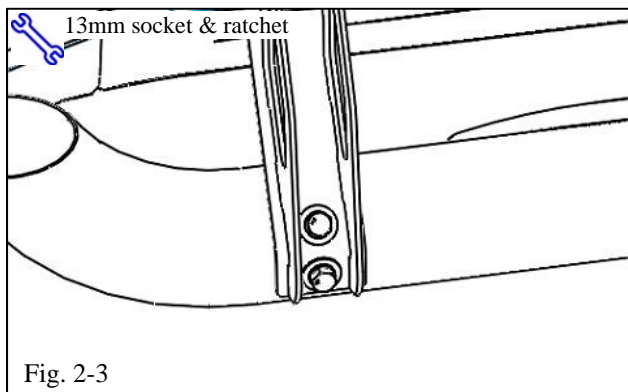



- (c) Use the supplied M8 hex head bolts, flat washers and lock washers to loosely attach the passenger side Step Bar to the mounting brackets (Fig. 2-3).

**3. Torque all Hardware.**

 (a) Confirm that the brackets are properly seated and perpendicular to the body.

(b) Torque the bolts to the body, outboard first then inboard (front to back).

 **Torque: 23 N-m (17 ft-lbf)**

 (c) Visually align the tube for flatness and torque the bolts to the step bar inboard first then outboard (front to back).

 **Torque: 23 N-m (17 ft-lbf)**

**4. Install the Driver Side Tube Step.**

(a) Repeat Steps 1 through 3 on the driver side.

**5. Re-torque all Hardware.**

(a) Re-torque all 24 bolts in the same order as Step 3.

 **Torque: 23 N-m (17 ft-lbf)**

(b) **PPO Only:** Complete the torque audit sheet within five minutes of the installation.

Checklist - these points **MUST** be checked to ensure a quality installation.

<u>Check:</u>	<u>Look For:</u>
<p><u>Accessory Function Checks</u></p> <ul style="list-style-type: none"><li><input type="checkbox"/> Tube Step alignment</li><li><input type="checkbox"/> Inspect bolt torques</li><li><input type="checkbox"/></li><li><input type="checkbox"/></li></ul>	<p>Ensure the tube step is centered on the vehicle</p> <p>Complete the torque audit sheet within 5 minutes of the installation (PPO only)</p>
<p><u>Vehicle Function Checks</u></p> <ul style="list-style-type: none"><li><input type="checkbox"/></li><li><input type="checkbox"/></li><li><input type="checkbox"/></li></ul>	
<p><u>Vehicle Appearance Check</u></p> <ul style="list-style-type: none"><li><input type="checkbox"/> After accessory installation and removal of protective cover(s), perform a visual inspection.</li></ul>	<p>Ensure no damage (including scuffs and scratches) was caused during the installation process.</p> <p>(For PPO installations, refer to TMS Accessory Quality Shipping Standard.)</p>