

Preparation

Part Number: PT890-03120-XX

NOTE: Part number of this accessory may not be the same as the part number shown.

Kit Contents

Item #	Quantity Reqd.	Description
1	1	Lip Spoiler
2	1	Hardware Bag

Hardware Bag Contents

Item #	Quantity Reqd.	Description
1	2	M6 Nuts

Additional Items Required For Installation

Item #	Quantity Reqd.	Description
1	1	Installation Kit, P/N PT890-03120

Conflicts

None

Recommended Tools

Personal & Vehicle Protection	Notes
Wrist and Belt Buckle Protectors	
Blankets	
Shop Rags	
Masking Tape	2" wide
Special Tools	Notes
Non Intrusive IR Temperature Probe/Gun	
Installation Tools	Notes
Drill Motor	1/2"
Twist Drill Bits	8.5 mm & 9.0 mm
Drill Stops	8.5 mm, 9.0 mm,
Hex Nut Driver	10 mm
Deep Well Socket	10 mm
Socket Extension	6"
Ratchet	
Torque Wrench	0-100 lbf-in
Shop Vacuum	
Hole Deburring Tool	
Magnet With Flex Shaft	
Panel Fastener Removal Tool	
Heat Gun	
Small Parts Bin	
Scissors	
Lint Free Cloth	

Special Chemicals	Notes
Sealant	3M Ultra-Pro Body Sealant
Cleaner	3M Prep Solvent 70

General Applicability

All Camry models

Recommended Sequence of Application







Item #	Accessory
1	None
2	

*Mandatory

Vehicle Service Parts (may be required for reassembly)

Item #	Quantity Reqd.	Description
1		
2		
3		

Legend

	STOP: Damage to the vehicle may occur. Do not proceed until process has been complied with.
	OPERATOR SAFETY: Use caution to avoid risk of injury.
	CAUTION: A process that must be carefully observed in order to reduce the risk of damage to the accessory/vehicle and to ensure a quality installation.
	TOOLS & EQUIPMENT: Used in Figures calls out the specific tools and equipment recommended for this process.
	REVISION MARK: This mark highlights a change in installation with respect to previous issue.
	SAFETY TORQUE: This mark indicates that torque is related to safety.

Procedure

Care must be taken when installing this accessory to ensure damage does not occur to the vehicle. The installation of this accessory should follow approved guidelines to ensure a quality installation.

These guidelines can be found in the "Accessory Installation Practices" document.

This document covers such items as:-

- Vehicle Protection (use of covers and blankets, cleaning chemicals, etc.).
- Safety (eye protection, rechecking torque procedure, etc.).
- Vehicle Disassembly/Reassembly (panel removal, part storage, etc.).
- Electrical Component Disassembly/Reassembly (battery disconnection, connector removal, etc.).

Please see your Toyota dealer for a copy of this document.

1. Trim Panel Removal.

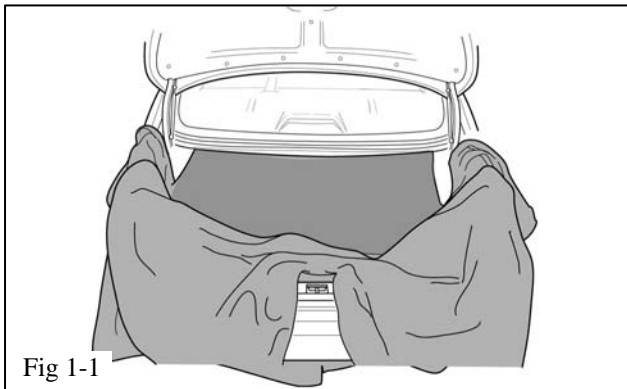

- (a) Open the trunk and place blankets inside on the trunk floor and trunk opening (Fig 1-1).

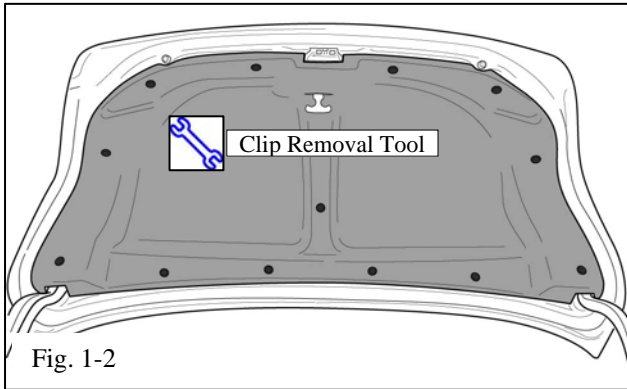

- (b) Remove the trunk lid inner trim panel by removing the 13 black clips (Fig, 1-2).

2. Hole Drilling.

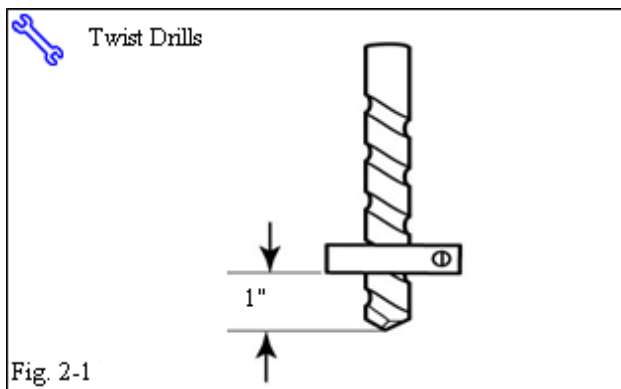

- (a) Eye protection must be worn during all drilling operations
- (b) Set all drill stops to 1" as shown. (Fig. 2-1)
- (c) When drilling holes, although not absolutely necessary, it can be very helpful to first drill a small pilot hole with a 3/32" or 1/8" bit. This will help to keep the larger drill bits from wandering.

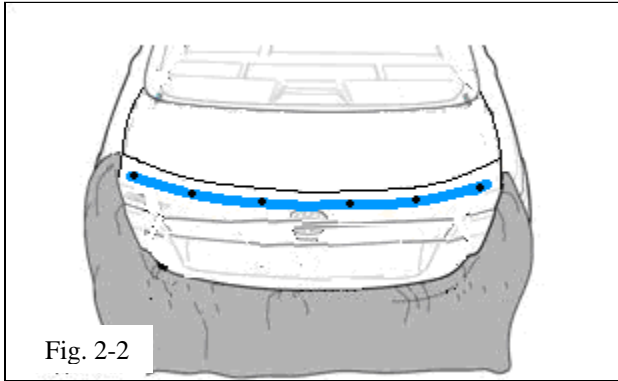

Fig. 2-2

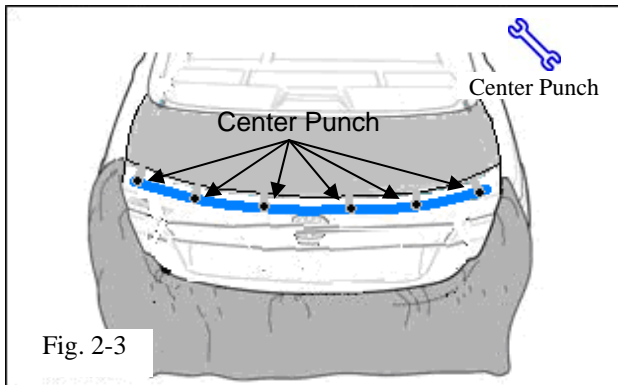

Fig. 2-3

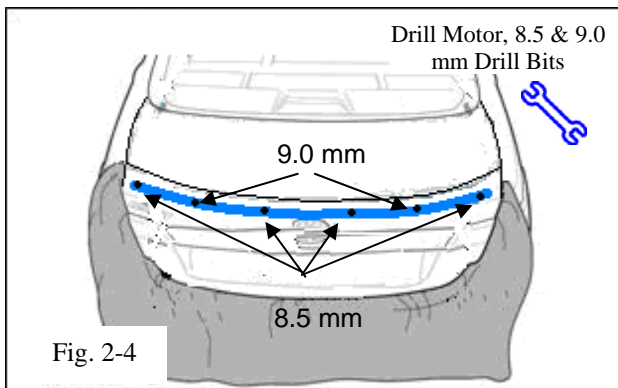

Fig. 2-4

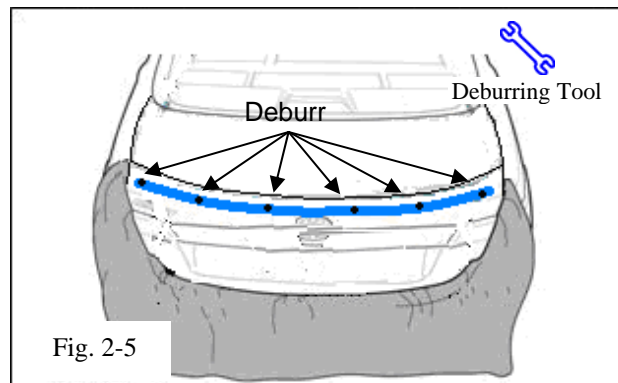

Fig. 2-5

(d) Apply masking tape to the trunk lid surface in the areas where the six (6) mounting holes will be drilled (Fig. 2-2). Two inch wide blue painters masking tape is recommended.

(e) Place the Mylar drilling template on the vehicle as shown. Tape in place, making sure template is completely smooth and flat on trunk lid surface (Fig. 2-3).

(f) Locate the six (6) hole locations on the template.

(g) Using a center punch, carefully punch each of the six hole locations through the Mylar Template onto the trunk lid. There is one hole location on each of the six tabs (Fig. 2-3).

(h) Remove the Mylar Template. Make sure you can see all six (6) punch marks.



NOTE: To help prevent drilling the wrong hole sizes at the six hole locations, it may be useful to write the hole diameter next to each punch mark on the masking tape (Fig. 2-4).

(i) Carefully drill the six mounting holes the correct diameters (Figs. 2-4).

(j) Using a deburring tool; carefully deburr the six (6) drilled holes (Fig. 2-5).

(k) Vacuum the surface of the trunk lid and the surrounding drilled areas. Remove masking tape.

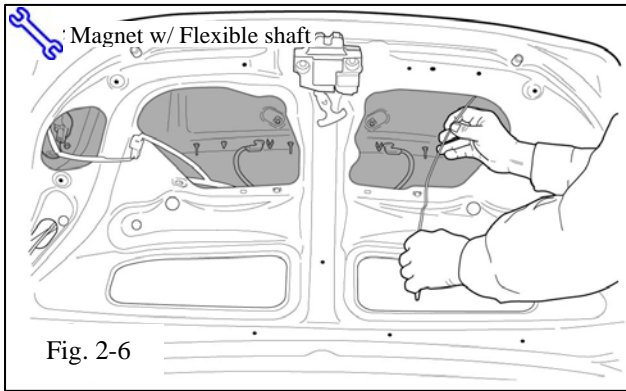

- (l) Open the trunk lid and use a magnet with a flexible shaft to remove any remaining metal chips from the drilling process (Fig. 2-6). Vacuum the inner panel area.

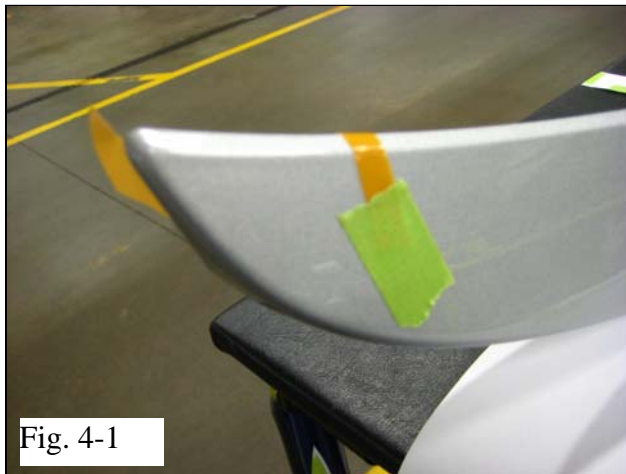

3. Preparation for Spoiler Attachment

- (a) Clean the surface of the trunk lid where the spoiler attaches with 3M Prep Solvent-70 and a lint free cloth.
- (b) After cleaning, carefully apply 3M Ultra-Pro Body Sealant to all drilled hole edges.
- (c) The trunk and spoiler should be a minimum of 60° F for proper set-up of adhesive tape. Use a hot air blower to heat the surface if the temperature is below 60° F. The adhesive tape on the spoiler must have full contact between spoiler and trunk lid for proper sealing to trunk lid.

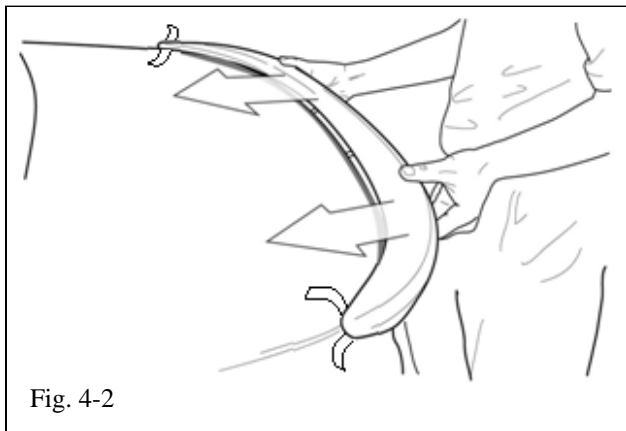

4. Attaching the Spoiler to the Lift Gate.

-  (a) Fold back and tape the plastic liners to the outside surface of the spoiler. Be careful not to touch or allow any contaminants to come into contact with the adhesive tape. (Fig 4-1)
- (b) Position the spoiler behind the trunk lid with the drill holes aligned to the spoiler studs and clips. The two studs go into the two 9.0 mm drilled holes aligning the Spoiler side to side and vertically (Fig. 4-2).

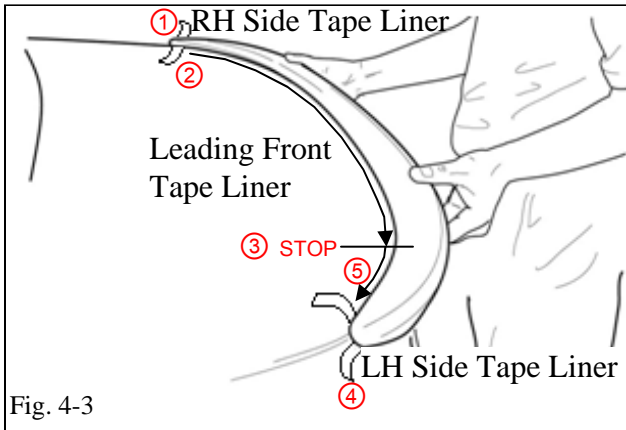

Fig. 4-3



- (c) Press spoiler into place seating the plastic clips into the 8.5 mm holes. (Fig. 4-3)
- (d) Once the clips are fully seated, use your fingers and center the spoiler from side to side on the trunk lid.
- (e) If there is a gap at the trailing edge of the spoiler, gently push the spoiler forward and remove either the LH or RH side tape liner from either side of the spoiler ①. Next, begin removing the leading front tape liner from the same side the side tape liner was removed ②. Apply light pressure as you remove the tape liner. Continue removing the leading front tape liner until you reach $\frac{3}{4}$ of the way across the spoiler and stop ③. Now remove the final side tape liner ④. Remove the remaining leading front tape liner ⑤. Reference Fig. 4-3 as an example.
- (f) Once the plastic liners are completely removed, re-apply pressure to the entire leading edge and sides of the spoiler to ensure good tape adhesion.



- (g) Open the trunk lid and install the two (2) M6 nuts to the studs. Torque the M6 nuts to 53 lbf-in (5.9Nm).



Fig. 5-1

5. Change Torque Rod Positions

- (a) Remove the clip shown from the trunk side panel (Fig. 5-1) and partially pull back the side panel to expose the torque rod.
- (b) Move the torque rod from the center slot to the most rearward slot (Figs. 5-2 & 5-3).
- (c) Reinstall side panel and trim.
- (d) Repeat for the opposite side.

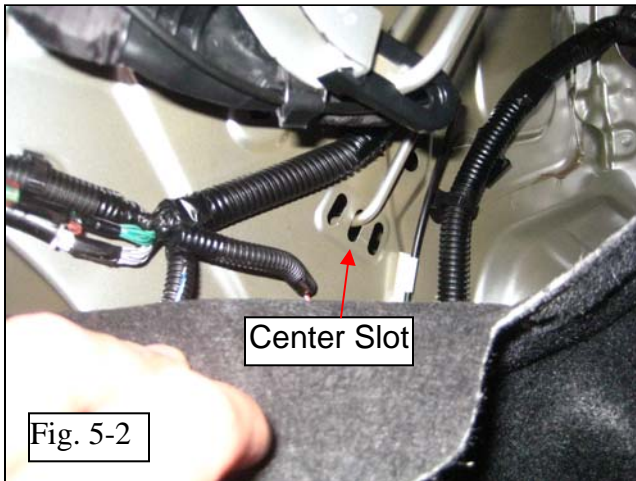

Fig. 5-2



6. Reassemble the Vehicle.

- (a) Reinstall all removed panels and parts. Be sure that all the panel clips are engaged.
- (b) Check that there are no drill shavings/chips in the vehicle trunk area and rear bumper.

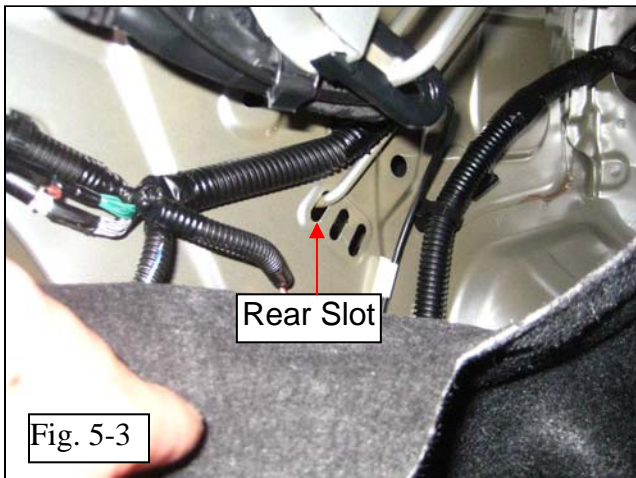

Fig. 5-3

Checklist - these points **MUST** be checked to ensure a quality installation.

<u>Check:</u>	<u>Look For:</u>
<u>Accessory Function Checks</u> <input type="checkbox"/> Check for spoiler alignment. <input type="checkbox"/> Check for full tape adhesion.	Centered from side to side (+/- 2.0 mm.) Full adhesion with no gaps.
<u>Vehicle Function Checks</u> <input type="checkbox"/> None Required	