

**Part Number: PT791-08150 (non-SE)
PT791-08102 (SE only)**

Kit Contents

Item #	Quantity Req'd.	Description
1	1	Trailer Module Harness
2	1	4-Flat Harness
3	1	Battery Power Wire Harness
4	1	Mounting Bracket, 4-Flat
5	2	Screw #10-24
6	2	Nut/Washer #10-24
7	28	Cable Tie 216mm (8.50")
8	1	Fuse Location Card
9	2	Aluminum Adhesive Tape 2"
10	4	Aluminum Adhesive Tape 4"
11	1	Gray Male Housing
2	30	Foam-Pad
13	4	Grommet Retaining Screw

Hardware Bag Contents

Item #	Quantity Req'd.	Description
1		

Additional Items Required For Installation

Item #	Quantity Req'd.	Description
1	1	3M Automotive Sealant

Conflicts

--

Recommended Tools

Personal & Vehicle Protection	Notes
Safety Glasses	
Cloth/Rag	
Protective Tape	
Special Tools	Notes
Circuit Tester	
Installation Tools	Notes
Ratchet	3/8" Drive
Socket	10mm, 12mm, 14 mm
Trim Panel Removal Tool	
Screwdriver	Phillips & Flat Head
Pliers	Diagonal Cutting
Wrench	12mm (optional)
Knife or Side Cutters	
Flexible Pickup Tool	
Torque Wrench	0-10 N•m (0-88 lbf•in)
Dremel Tool (2017-)	TR408 drum sander
Special Chemicals	Notes
VDC Approved Cleaner	

General Applicability

PT791-08150 fits non-SE models
PT791-08102 fits SE models only

Recommended Sequence of Application







Item #	Accessory
1	Trailer Module Harnesses
2	Hitch
3	4-Flat Harness
4	Mud Guard

*Mandatory

Vehicle Service Parts (may be required for reassembly)

Item #	Quantity Req'd.	Description
1		
2		
3		

Legend

	STOP: Damage to the vehicle may occur. Do not proceed until process has been complied with.
	OPERATOR SAFETY: Use caution to avoid risk of injury.
	CAUTION: A process that must be carefully observed in order to reduce the risk of damage to the accessory/vehicle and to ensure a quality installation.
	TOOLS & EQUIPMENT: Used in Figures calls out the specific tools and equipment recommended for this process.
	REVISION MARK: This mark highlights a change in installation with respect to previous issue.
	SAFETY TORQUE: This mark indicates that torque is related to safety.

Care must be taken when installing this accessory to ensure damage does not occur to the vehicle. The installation of this accessory should follow approved guidelines to ensure a quality installation.



These guidelines can be found in the "Accessory Installation Practices" document.

This document covers such items as:-

- Vehicle Protection (use of covers and blankets, cleaning chemicals, etc.).
- Safety (eye protection, rechecking torque procedure, etc.).
- Vehicle Disassembly/Reassembly (panel removal, part storage, etc.).
- Electrical Component Disassembly/Reassembly (battery disconnection, connector removal, etc.).

Please see your Toyota dealer for a copy of this document.

1. Prepare the Vehicle.

-  (a) Professional installation by an authorized dealer is highly recommended. Read all instructions thoroughly prior to installation. Ensure all parts are included in the kit and follow all vehicle safety guidelines.
-  (b) Read all battery warnings on disconnecting and reconnecting the vehicle's battery terminal from the battery. Follow all procedures and disconnect and isolate the negative battery terminal.
-  (c) Wear safety glasses and take all safety precautions during installation.

2. Disassemble the Vehicle (Interior).

- (a) Open the tail gate and both driver's side door doors (front and sliding).
-  (b) Open the hood and locate the battery on the driver's side of the vehicle. Use a 10mm wrench to disconnect the negative battery cable and isolate the negative battery terminal (Fig. 2-1).

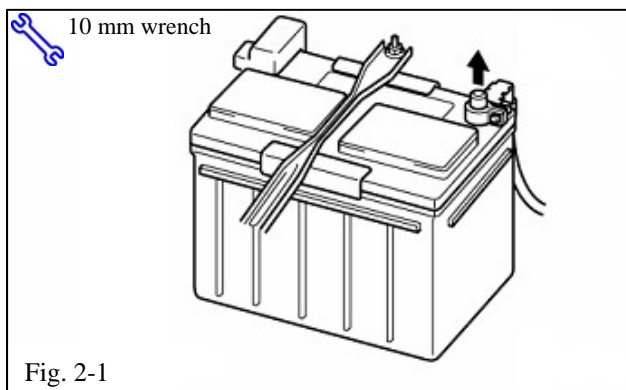

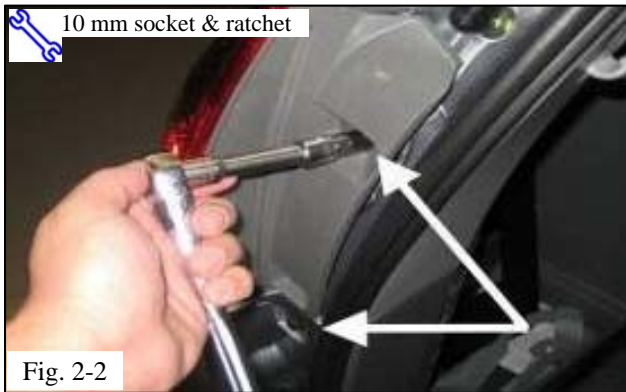

(c) Use a 10mm socket & ratchet to temporarily remove the 2 bolts holding the tail lamp assemblies in place on each side of the vehicle (Fig. 2-2).



(d) Carefully pry the tail lamp assembly away from the vehicle (pull directly rearward) until the clips release (Fig. 2-3).

(e) Locate the 2 vehicle connectors at the rear of the tail lamp assembly and disconnect them from the tail lamp assembly (2 per side) (Fig. 2-3).

⚠ NOTE: Be careful not to break the locking tabs.

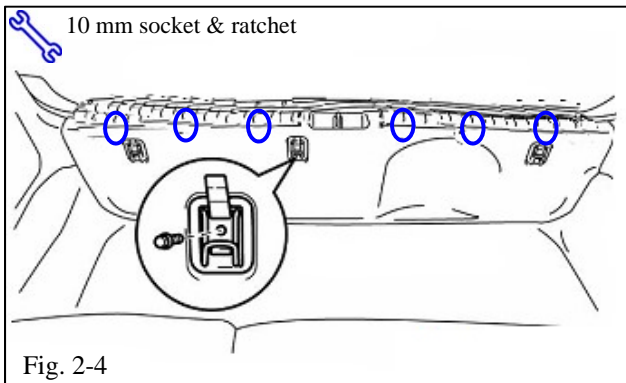

(f) In the rear cargo area, locate the 3 cargo net hook tie downs. Use a 10mm socket & ratchet to temporarily remove them (Fig. 2-4).

(g) Use a trim panel removal tool to gently pry the threshold plate up and away from the vehicle (Fig. 2-4).

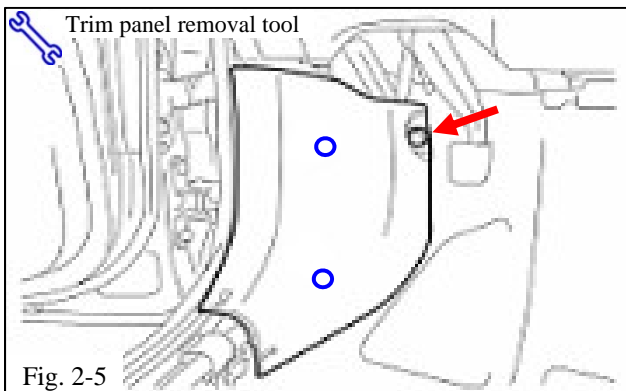

(h) Remove the kick panel (Fig. 2-5).

(1) Remove the fastener (arrow).

(2) Use a trim panel removal tool to gently pry the kick panel plate up and away from the vehicle (clips indicated by circles).



- (i) Use a trim panel removal tool to pry the plastic threshold step plates off at both openings, (Fig. 2-6).

⚠ NOTE: Be careful not to break the plastic clips.



- (j) Slide the driver's side second row seat forward (Fig. 2-7).



- (k) Locate the third row seatbelt lower restraint attachment on the driver's side (arrow). Pry the cover off and use a 14mm socket & ratchet to remove the bolt (Fig. 2-8).

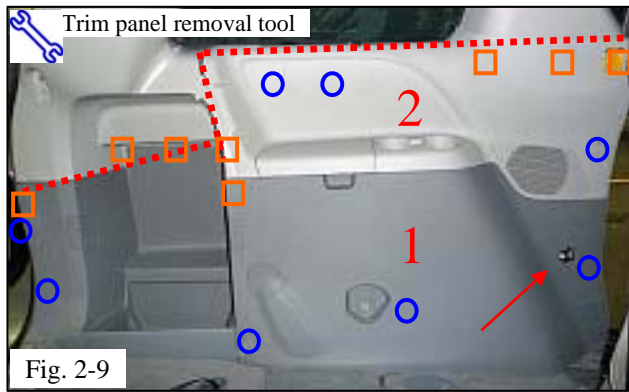

- (l) Use a trim panel removal tool to remove the driver's side rear panel from the sliding door to the rear tailgate area (red dashed line), including the panel under the window (Fig. 2-9). If present, remove the sensor (arrow).

NOTE: If the vehicle has the rear seat entertainment option installed, be sure to disconnect the headphone jack wire harness when removing the trim panel.

NOTE: The panels are fused together. Remove both panels as one whole piece, being very careful to not break the plastic clips (○) and claws (□) in the process.



- (m) Temporarily remove the black support bracket (Fig. 2-10).



- (n) Remove the jack storage cover on the rear passenger's side (Fig. 2-11).



- (o) Use a trim panel removal tool to pry the passenger's side rear panel partially away from the vehicle (Fig. 2-12).

3. Disassemble the Vehicle (Exterior).

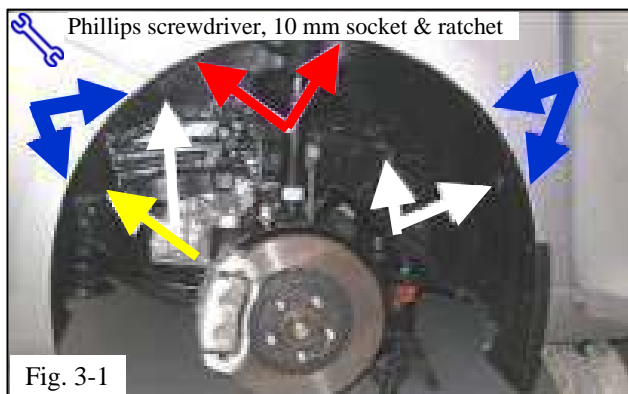

- (a) If necessary, for ease of installation, remove the driver's side front tire. Make sure to support the vehicle and follow all Toyota safety guidelines.

- (b) Remove the 2 plastic fasteners at the top of the wheel well that hold the plastic under liner in place (red arrows, Fig. 3-1).

- (c) Use a Phillips head screwdriver to remove the 3 screws (white arrows) on the edge of the wheel well, 1 forward and 2 rearward, that hold the plastic under liner in place.

- (d) Remove the plastic fastener located at the forward bottom position of the under liner (yellow arrow, Fig. 3-1).

- (e) Use a 10mm socket and ratchet to remove the 6 bolts, 2 forward and 4 rearward, inside the wheel well that hold the plastic under liner in place (blue arrows, Fig. 3-1). Once the bolts are removed, cut the plastic grommet retainer clips off (additional clips are provided for reinstallation).

- (f) With most of the fasteners removed, partially pull the shield down to gain access to the area for routing the trailer wire harness power wire.

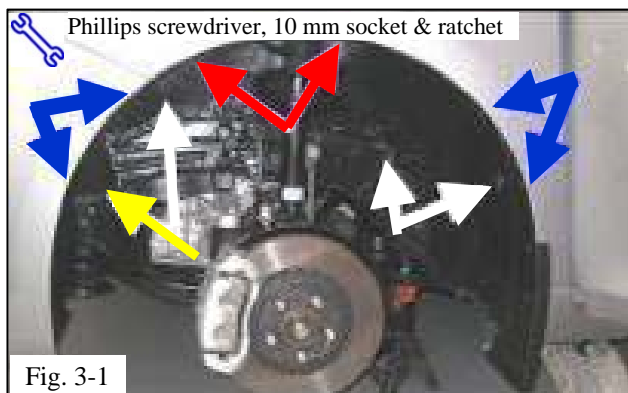

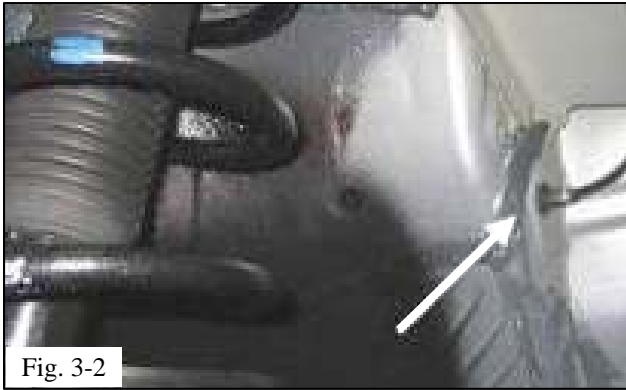

- (g) Locate the hood release cable and grommet rearward of the suspension and pull it out of the hole to access the grommet (Fig. 3-2).

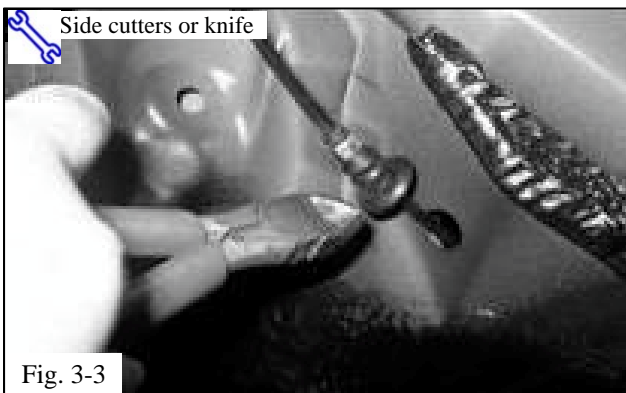



- (h) Use side cutters or a knife to slit the grommet 6mm (1/4") at the base to allow the trailer power wire to slide through freely (Fig. 3-3).

4. Install the Trailer Wire Harness.

- (a) Locate the trailer power wire provided and if not already removed, remove the 15 amp fuse before proceeding. The fuse will be re-installed later.

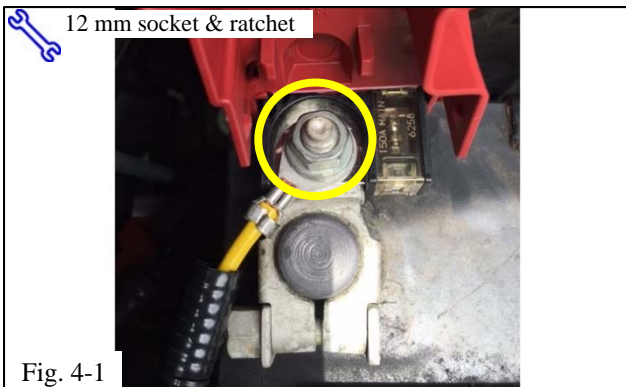
-  (b) Remove the nut on the top of the positive battery clamp and attach the power wire ring terminal (Fig. 4-1). Tighten the nut to 12.75 N•m (113 lbf•in).



 **Torque: 12.75 N•m (113 lbf•in)**

-  **NOTE:** Be sure to position the ring terminal to the inside of the vehicle as shown.

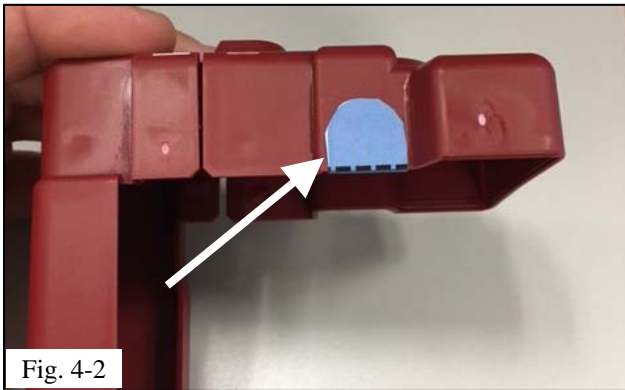

(c) Cut out the provided template and attach it to the cover (Fig. 4-2).



(d) Mark the cover around the template. Grind the cover with a Dremel and TR408 drum sander in the outline from the template (approximately 12mm). The opening should appear similar to Fig. 4-3.



(e) Use a side cutter to trim approximately 2 mm from the inside leg of the cover (Fig. 4-4).

(f) Reattach the cover and confirm the cover closes firmly.

⚠ NOTE: Additional trimming of the inside leg may be required to ensure the cover closes completely.

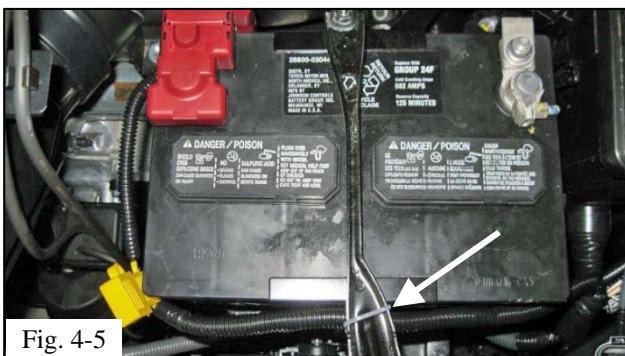

(g) Route the wire harness in front of the battery under the battery hold down. Use a cable tie (arrow) to attach the fuse holder harness to the battery hold down (Fig. 4-3).



- (h) Route the wiring along the battery over to the driver's side fender. Start securing the wire harness with cable ties following the same path as the hood release cable (arrows, Fig. 4-6).

⚠ NOTE: The battery may need to be adjusted side to side.

- (i) Use 2 cable ties to secure the power wire to the existing vehicle harnesses inside the engine bay, spaced out approximately every 150mm (6 inches).
- (j) Route the rest of the power wire into the wheel well area.
- (k) Once inside the wheel well, locate the slit grommet hole and route all of the excess trailer power wire thru it into the interior of the vehicle.

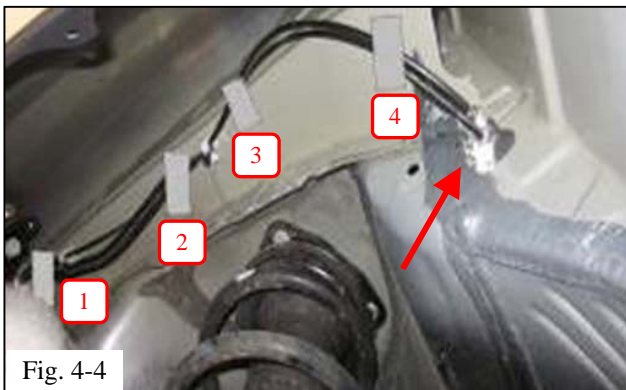

- (l) Reset the grommet back into the hole and then use putty sealant (not provided), making sure that the putty completely seals around the wire (arrow) and grommet to prevent moisture from getting into the vehicle (Fig. 4-4).
- (m) Use four pieces of 4" adhesive tape to secure the power wire to the vehicle following the existing hood release cable path, spaced out approximately every 150mm (6 inches) (Fig. 4-4).



(n) Route the power wire under the dash, along the kick panel, following the existing wiring harnesses. Use 2 cable ties (arrows) spaced out approximately every 150mm (6 inches) to secure the new harness to the existing harness (Fig. 4-5).



(o) Continue to route the power wire along the driver's side threshold following the existing wiring harnesses. Use 5 cable ties (arrows) spaced out approximately every 150mm (6 inches) to secure the new harness to the existing harness (Fig. 4-6).

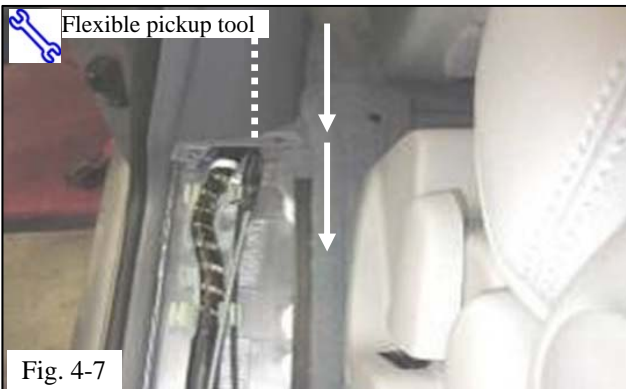

(p) Route the wire following the existing wiring harnesses under the cross member along the center post (arrows/dotted line, Fig. 4-7).

(q) Use a flexible pickup tool to route the power wire between the front and rear door behind the panel following the existing wiring harness (Fig. 4-7).



(r) Continue routing the power wire along the sliding door threshold following the existing wiring harnesses. Use 6 cable ties (arrows) spaced out approximately every 150 mm (6 inches) to secure the new harness to the existing harness (Fig. 4-8).

 (s) Before proceeding, make sure that the panels and threshold plates can be reinstalled and do not cut or pinch the power wire or the existing wiring.

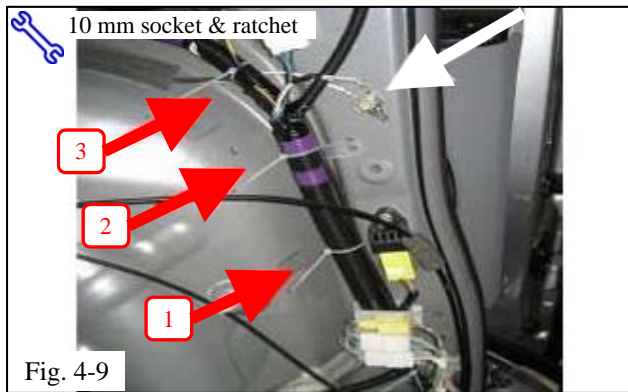

- (t) Use a 10 mm socket & ratchet to attach the white wire with the ring terminal from the Trailer Tow Module to the existing ground stud just rearward of the sliding door (white arrow, Fig. 4-9).

⚠ NOTE: When installing the ring terminal, make sure to reattach the existing ground wires.

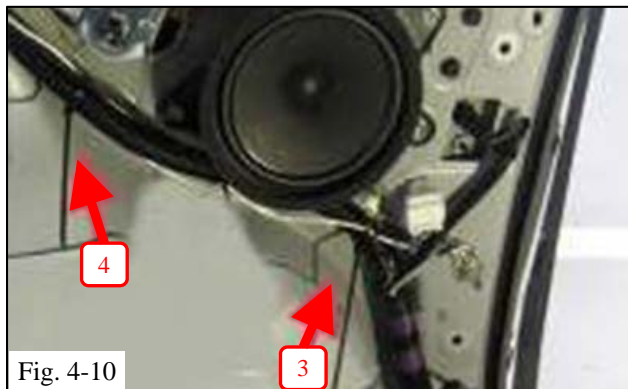

- (u) Route the power wire up and over the rear wheel well following the existing wiring harnesses. Use 4 cable ties (arrows) spaced out as shown in Fig. 4-9 & 4-10 to secure the new harness to the existing harnesses.
- (v) Route both the ground wire and the power wire together over the rear wheel well (Fig. 4-10).



- (w) Wrap 2" silver adhesive tape over the pinch weld rearward of the speaker (Fig. 4-11).

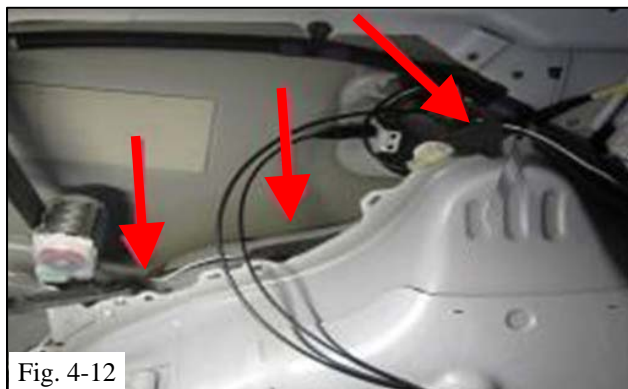

- (x) Use three foam pads spaced out approximately every 150 mm (6 inches) to secure both wires to the sheet metal surface (Fig. 4-12).

⚠ NOTE: Make sure the wire goes over the pinch weld from Step 4(s) before applying the foam pad.



Fig. 4-13



Fig. 4-14



Fig. 4-15

(y) Once inside the rear cargo area, insert the power wire into the gray provided housing and push the white tab to lock the wire into position (Fig. 4-13 & Fig. 4-14).

(z) Locate the mating gray connector on the trailer tow module and plug the power wire into it (Fig. 4-15).



Fig. 4-16

(aa) Locate the rear air baffle in the rear cargo area on driver's side wall. Use a VDC approved cleaner to clean an area below the baffle for mounting the trailer tow module (Fig. 4-16).

(bb) Peel the backing off of the tape and attach the module as shown (Fig. 4-16).



(cc) Locate the black mating plug near the trailer tow module and plug the 4-flat mating harness into it. Be sure that the connectors are fully inserted.

(dd) Run the white (ground) wire, the black (power) wire and the green (RH tail lamp) wire below the module towards the front of the vehicle and secure them with a cable tie to module's fastener hole (Fig. 4-17).

(ee) Bundle the excess ground and power wire as shown in Fig. 4-17 and secure it with a cable tie (right arrow) together with the green wire and 4P wire harness. Ensure the cable tie also secures the mating gray (power) connector (Fig. 4-15).

(ff) Use foam tape to secure the 4P wire harness and green RH tail lamp wire (in convolute wrap) across the pinch weld rearward of the support frame (left arrow, Fig. 4-17).

(gg) Pull back the carpet in the rear area. Route the 4P wire harness and green RH tail lamp wire as shown in Fig. 4-18. Continue routing / securing the wires with foam pads as shown in Fig. 4-18.



⚠ NOTE: The green RH tail lamp wire must follow the path shown.



(hh) Locate and remove the rear most grommet on the driver's side (Fig. 4-19). Route the 4P wire harness through the grommet hole and install the provided grommet.



(ii) Loop the excess 4P wire harness and secure it and the green RH tail lamp wire using foam pads (Fig. 4-19 & Fig. 4-20).

⚠ NOTE: Do not bend the 4P wire harness excessively!

(jj) Use foam pads to secure the excess 4P wire harness with green RH tail lamp wire to the sheet metal surface (circle, Fig. 4-20).

⚠ CAUTION: DO NOT loop any green RH tail lamp wire.

(kk) Continue routing the green RH tail lamp wire over to the passenger's side tail lamp (Fig. 4-20).

(ll) Use 2 pieces of foam tape to secure the green RH tail lamp wire (Fig. 4-21).

⚠ NOTE: The green RH tail lamp wire is protected with corrugated tube but it does not show in Fig. 4-21.



(mm) Gently pull back the passenger's side rear trim panel and route the green RH tail lamp wire up the panel to the jack storage area (4-22).

⚠ NOTE: The wire is protected with corrugated tube. Secure it with foam pads to the sheet metal surface (Fig. 4-22).



⚠ NOTE: The dotted circle represents foam tape applied from the back of the sheet metal (Fig. 4-25).



Fig. 4-23

(nn) Locate the opening behind the tail lamp and route the trailer tow harness into the tail lamp area. Continue routing the wire to the tail lamp following the existing tail lamp housing wiring (Fig. 4-23). Plug the trailer tow 2 pin housing in between the vehicle plug and the tail lamp assembly.

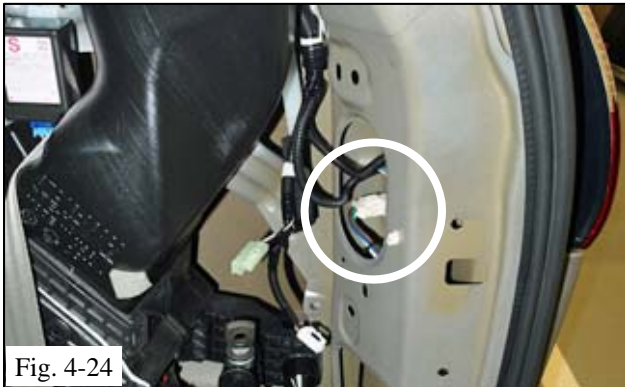

Fig. 4-24

(oo) Plug the vehicle 4 pin housing back into the RH tail lamp assembly and insert the clip into the hole in the sheet metal (Fig. 4-24). Reinstall the tail lamp assembly, being careful not to pinch or cut the wiring.

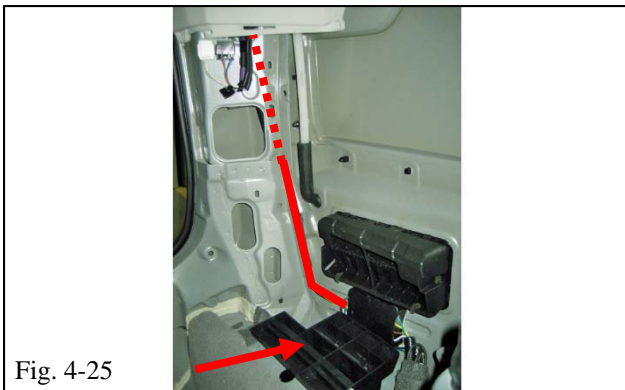

Fig. 4-25

(pp) On the driver's side (LH), place the black plastic support tray (arrow) back into position and align it with the notches (Fig. 4-25).

(qq) Locate the opening behind the tail lamp and route the LH tail lamp wire harness with the yellow, brown & red wire into the tail lamp area (Fig. 4-25).

⚠ NOTE: The wire is protected with corrugated tube. Follow the line in Fig. 4-25.

⚠ NOTE: The dotted line is represents the route from the back of the sheet metal (not seen in this view).

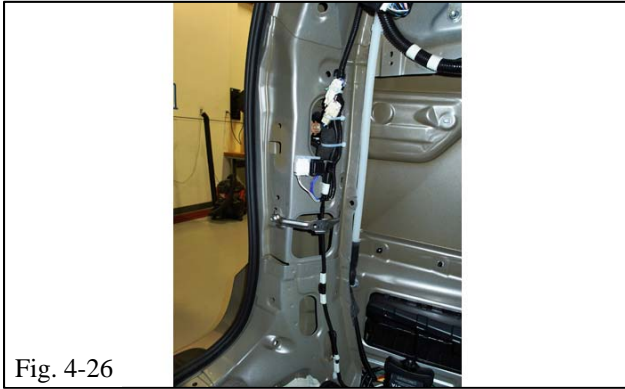

Fig. 4-26

(rr) Route the LH tail lamp wire harness to the tail lamp following the existing tail lamp housing wiring (Fig. 4-26).

STOP (ss) Plug the trailer tow 2 pin housing in between the vehicle plug and the tail lamp assembly. Place a foam tape pad over the vehicle wire harness and the LH tail lamp wire plug to reduce vibration noise (Fig. 4-26).

STOP (tt) Plug the trailer tow vehicle 4 pin housing in between the vehicle plug and the tail lamp assembly. Place a foam tape pad over the vehicle wire harness and the LH tail lamp wire plug to reduce vibration noise (Fig. 4-26).

(uu) Reinstall the LH tail lamp assembly, being careful not to pinch or cut the wiring.

(vv) Secure the LH tail lamp wire harness / corrugated tube with a foam pad to the sheet metal surface below the opening of the LH tail lamp.

(ww) Bundle and secure the excess LH tail lamp wire harness to the sheet metal surface using a foam pad (Fig. 4-27).

(xx) Install the hitch. See the hitch installation guide.

(yy) Locate the 4P wire harness underneath the vehicle from Step 4(hh) (refer to Fig. 4-19).



Fig. 4-27



(zz) Use the two provided screws and nuts to mount the 4-Flat bracket on top of the Toyota trailer hitch wire harness bracket (Fig. 4-28).

⚠ NOTE: Ensure the 4-Flat bracket is sitting on a top of the hitch bracket.

(aaa) Assemble two wire ties in series to create a 14” cable tie assembly and route the 4-Flat connector through the opening at the backside of the trailer hitch bracket. Ensure the wire harness is on the top of the towing hitch torsion bar and secure it with the cable ties (circle) (Fig 4-28).

(bbb) Push the 4-Flat connector through the mounting bracket past the first detent (Fig. 4-29).

(ccc) Make sure that all connections are completely installed on the trailer harness.

5. Reassemble the Vehicle.

(a) Reposition all of the panels, carpet, threshold, weather strip and components removed in Step 3.

(b) Tighten the seat belt to 42 N•m (31 lbf•ft).

⚠ Torque: 42 N•m (31 lbf•ft)

(c) Replace the tire and torque the lug nuts to 103 N•m (76 lbf•in).

⚠ Torque: 103 N•m (76 lbf•ft)

(d) Reconnect the vehicle’s negative battery cable. Tighten the nut to 5.4 N•m (48 lbf•in).

⚠ Torque: 5.4 N•m (48 lbf•in)

+ **CAUTION:** Do not touch the positive terminal with any tool when installing the negative battery cable.

- (e) Insert the 15 amp fuse from Step 4(a) into fuse holder.
- (f) Place the installation instructions and fuse location card in the owner's manual for future reference.
- (g) Perform the functional checks for the trailer wire harness and the post-installation checks for the vehicle (see next page).

 (h) Overloading the circuit can cause a fire. DO NOT exceed the load of the towing manufacturer rating.

- (1) Maximum stop/turn light load: 2 bulbs per side (total 4.2 amps)
- (2) Maximum tail lights load: 7.5 amps

**THIS PAGE
INTENTIONALLY
LEFT BLANK**

Positive Battery Cover Trimming Template

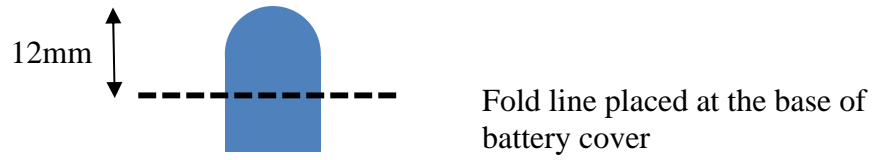

**THIS PAGE
INTENTIONALLY
LEFT BLANK**

TOYOTA SIENNA 2017 - TRAILER WIRE HARNESS
 Checklist - these points **MUST** be checked to ensure a quality installation.

- Check:
- Accessory Function Checks
- Right turn signal
 - Left turn signal
 - Brake
 - Tail light
 - Tail light & brake
 - Left turn & brake
 - Right turn & brake

- Look For:
- Circuit 1 flashes
 - Circuit 2 flashes
 - Circuit 1 & 2 activate
 - Circuit 3 activates
 - Circuit 1, 2 & 3 activate
 - Circuit 1 activates & 2 flashes
 - Circuit 1 flashes & 2 activates

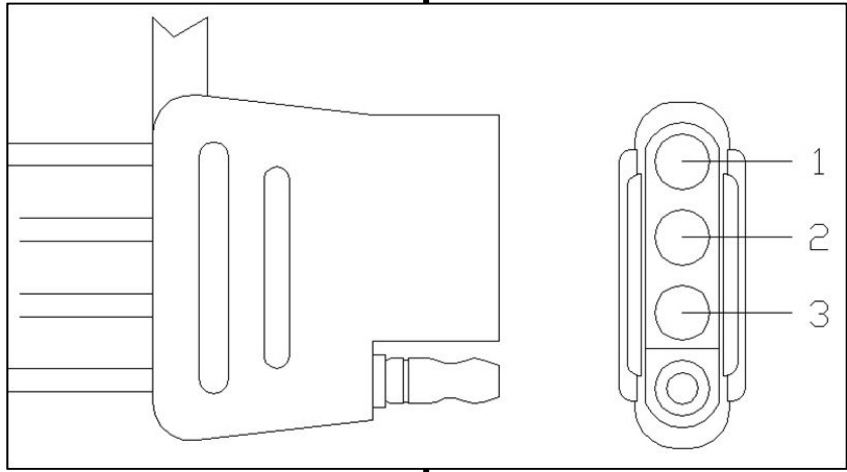

- Vehicle Function Checks
- Individual vehicle light functions
 - Warning lights
 - ||** Rear entertainment headphone jack

Verify that the corresponding vehicle lights activate. If light does not activate then check the connection.

No warning lights illuminated in the combination meter

Audio can be heard

