

Part Number: PT767-48201

Kit Contents

Item #	Quantity Req.	Description
1	1	Front Crossbar
2	1	Rear Crossbar
3	4	Crossbar Covers
4	1	Hardware Bag

Hardware Kit Contents

Item #	Quantity Req.	Description
1	1	Torque Tool
2	1	Users Manual
3	1	4 Pouch Plastic Bag
4	4	J-hook Bolts
5	4	Wedge Lock Washers
6	4	Attachment Nuts

Additional Items Required For Installation

Item #	Quantity Req.	Description
1		
2		

Conflicts

w/side Rails Models

Recommended Tools

Personal & Vehicle Protection	Notes
Safety Glasses	
Blanket	
Special Tools	Notes
Plastic Trim Removal Tool	
Installation Tools	Notes
Torque Wrench	0-2 N.m
Torx bit	T27
13 mm socket	
Ratchet	3" extension
Plastic Trim Removal Tool	
Special Chemicals	Notes

General Applicability

MY20 and newer Highlander, Highlander HV models (w/o side rails)
--

Recommended Sequence of Application

Item #	Accessory
1	
2	

*Mandatory

Vehicle Service Parts (may be required for reassembly)

Item #	Quantity Req.	Description
1		
2		
3		

Legend

 **STOP:** Damage to the vehicle may occur. Do not proceed until process has been complied with.

 **OPERATOR SAFETY:** Use caution to avoid risk of injury.

 **CAUTION:** A process that must be carefully observed in order to reduce the risk of damage to the accessory/vehicle and to ensure a quality installation.

 **TOOLS & EQUIPMENT:** Used in Figures calls out the specific tools and equipment recommended for this process.

 **REVISION MARK:** This mark highlights a change in installation with respect to previous issue.

 **SAFETY TORQUE:** This mark indicates that torque is related to safety.

 **REGULATORY MARK:** This mark indicates the component is related to regulatory compliance

Care must be taken when installing this accessory to ensure damage does not occur to the vehicle. The installation of this accessory should follow approved guidelines to ensure a quality installation.

These guidelines can be found in the "Accessory Installation Practices" document.

This document covers such items as:-

- Vehicle Protection (use of covers and blankets, cleaning chemicals, etc.).
- Safety (eye protection, rechecking torque procedure, etc.).
- Vehicle Disassembly/Reassembly (panel removal, part storage, etc.).
- Electrical Component Disassembly/Reassembly (battery disconnection, connector removal, etc.).

Please see your Toyota dealer for a copy of this document.

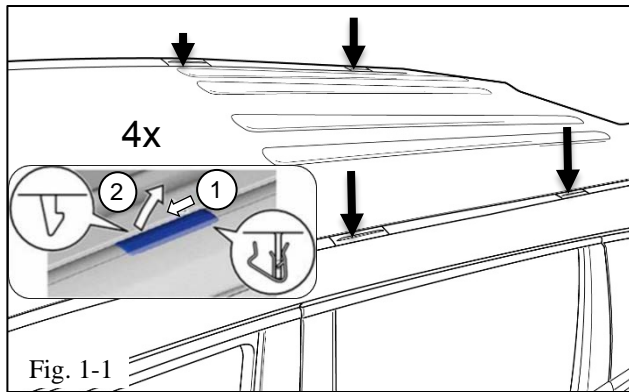

1. Remove the Covers

|| **NOTE:** Cover the vehicle roof with a protective covering to prevent scratching vehicle roof.

- STOP** (a) Locate 4 covers in the ditch molding on the roof of the vehicle (Fig. 1-1).
- (b) Remove four (4) covers by sliding the cap in the direction of the double arrows and lifting up the opposite end. Save them in the storage bag in the kit.

NOTE: Check and ensure spring clip remains on the cover.

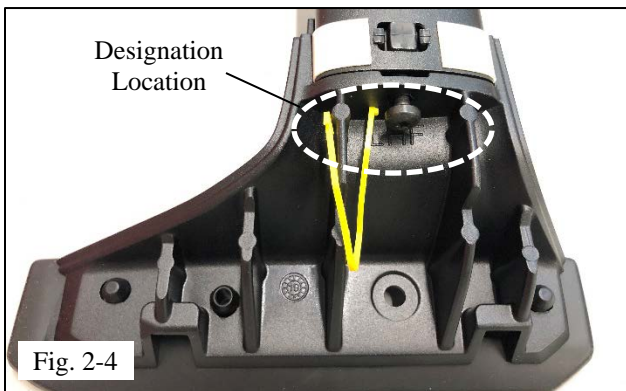
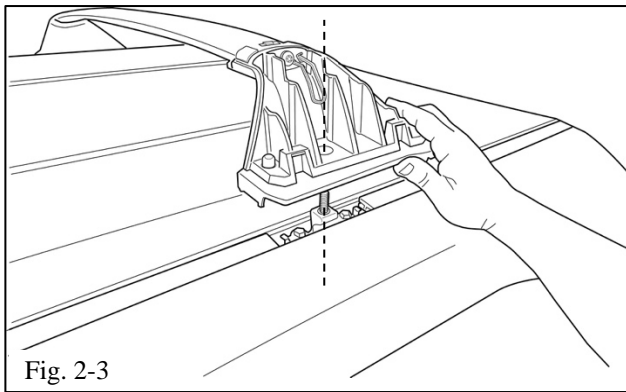
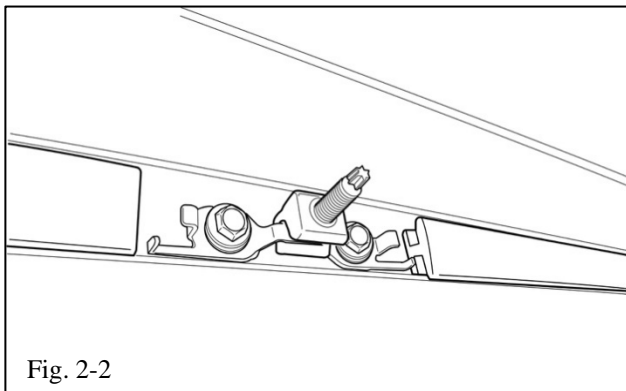
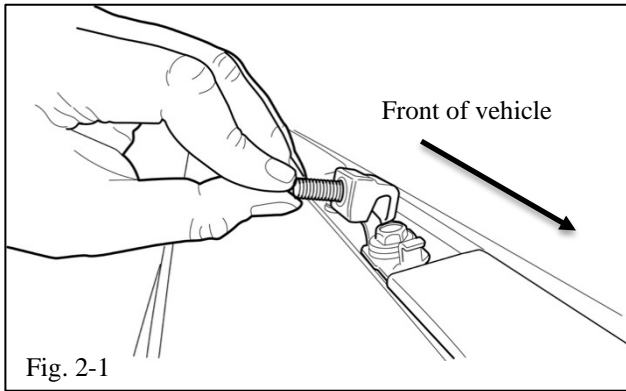

2. Install the Crossbars

- (a) Carefully open poly bag and remove content. Save the poly bag for later use.
- (b) Install the J-hook bolts onto the brackets with the J-hook bolt opening facing outward from the vehicle (Fig. 2-1 and Fig. 2-2).



NOTE: Ensure the J-hook bolt opening is facing outward. Reverse installation of the J-hook bolts will result in misalignment.

- (c) Place crossbar stanchions over J-hook bolts (Fig. 2-3).



NOTE: Ensure crossbars are in the correct position by designations on stanchions LHF, RHF, and LHR, RHR (Fig. 2-4).

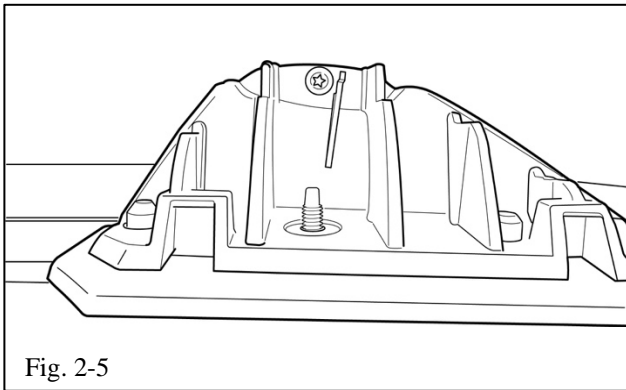

STOP NOTE: Ensure crossbar is centered and bolt is upright (Fig. 2-5).

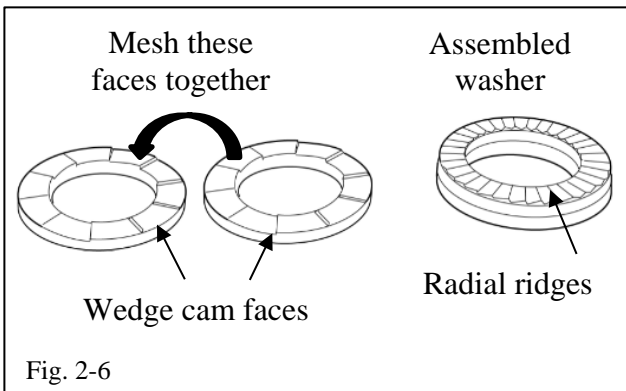

(d) Place an assembled Wedge Lock Washer onto the bolt.

! NOTE: Ensure wedge lock washers are correctly assembled. The washers should have the wedge cam faces together, and the radial ridges facing out (Fig. 2-6).

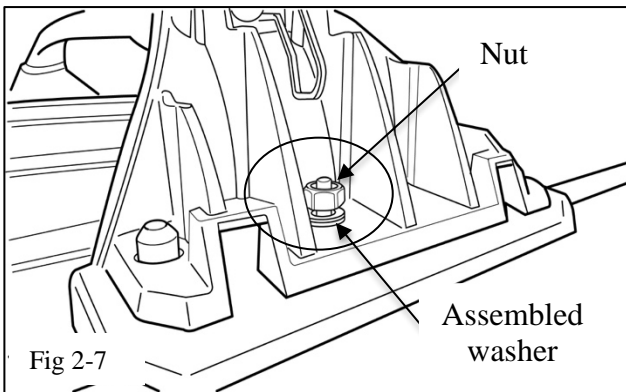

(e) Hand start and fasten a nut onto the bolt (Fig. 2-7).

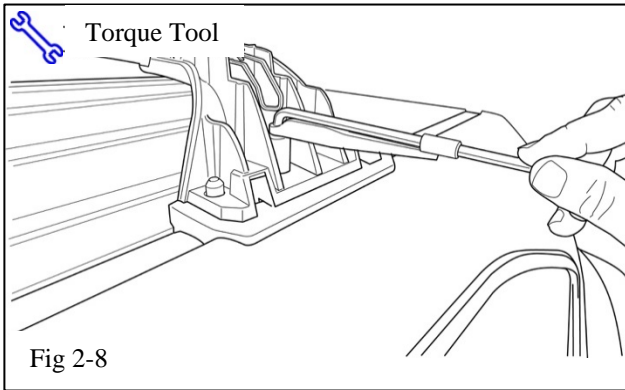

⚠ (f) Torque nuts to 15 N-m (11 ft-lb) (Fig. 2-8).

(g) Tighten only left side Crossbar Attachment screw to specification below (Fig. 2-9).

⚠ (1) **For PPO installation:** Torque the screw to 1 N-m (0.7 ft-lb).

(2) **For DIO Installation:** Fasten the screw until screw head bottoms out against stanchion. Then tighten until snug (1-3 turns).

⚠ **NOTE:** Do not loosen or tighten right side crossbar attachment screw.

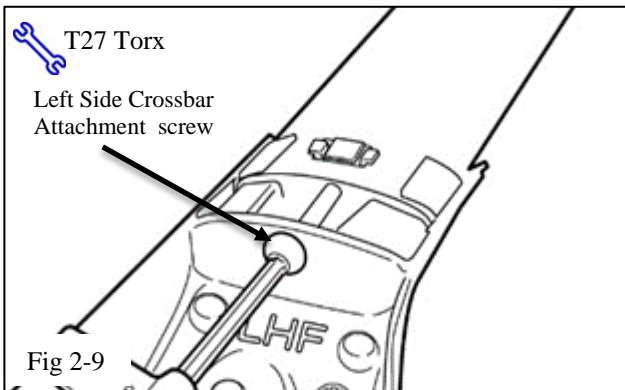

3. Install Covers Onto the Crossbar

(a) Insert the fish hook end of the tether through the hole in the corresponding cover (Fig. 3-1 and Fig. 3-2).

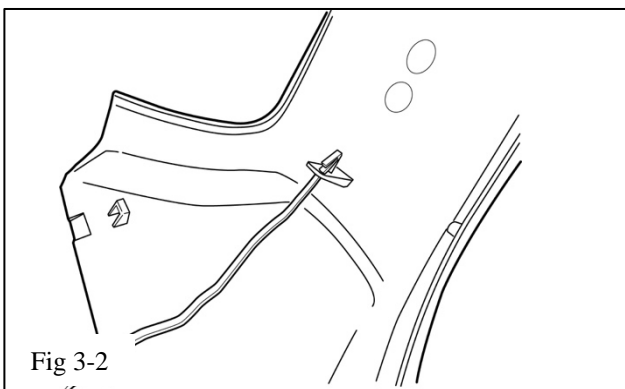
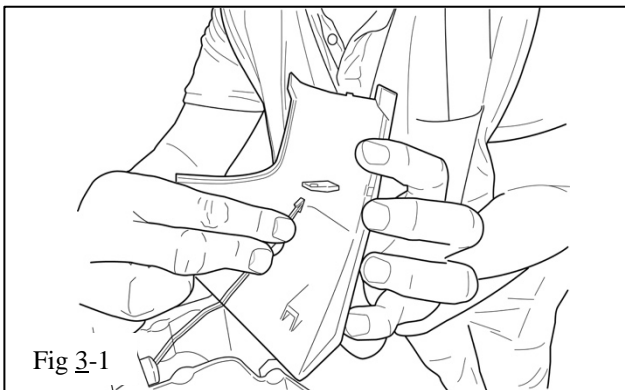

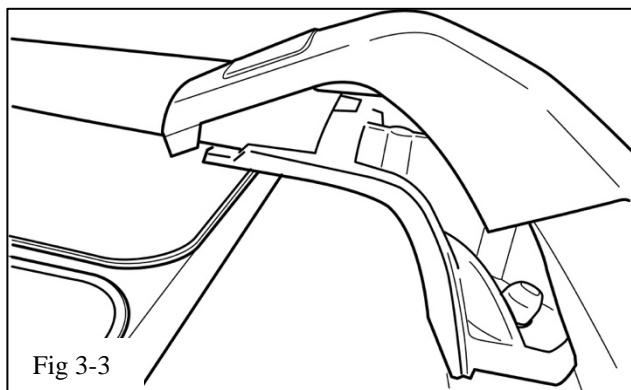

- (b) Slide the top of the cover over the extrusion and snap the cover into place (Fig. 3-3 and Fig 3-4).

⚠ NOTE: Ensure covers are properly seated over extrusion at top and along all edges after snapping into place.

- (c) Repeat steps (2) through (3) with the second crossbar.

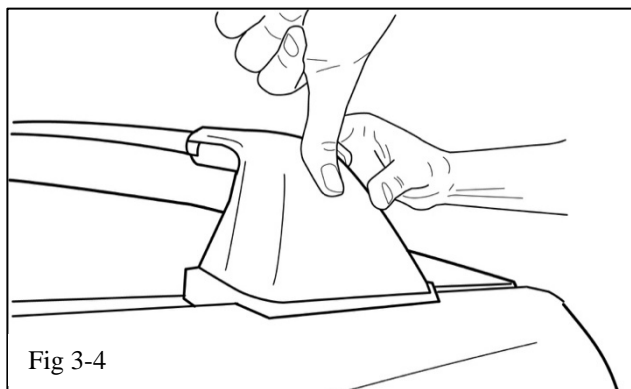

4. Complete the Installation

- || (a) Remove the protective covering on the roof.
- || (b) Place the torque wrench and user's manual in the poly bag. Place the poly bag with contents and covers saved from Step 1 (b) in the glove box or center console

Checklist - these points **MUST** be checked to ensure a quality installation.

<u>Check:</u>	<u>Look For:</u>
<p><u>Accessory Function Checks</u></p> <ul style="list-style-type: none"><input type="checkbox"/> Crossbar cover engagement<input type="checkbox"/> Side rail covers, User's Manual, and torque tool	<p>Ensure crossbar covers are fully engaged.</p> <p>Side rail covers, users guide and torque tool inside vehicle glove box.</p>
<p><u>Vehicle Function Checks</u></p> <ul style="list-style-type: none"><input type="checkbox"/>	
<p><u>Vehicle Appearance Check</u></p> <ul style="list-style-type: none"><input type="checkbox"/> After accessory installation and removal of protective cover(s), perform a visual inspection.	<p>Ensure no damage (including scuffs and scratches) was caused during the installation process.</p> <p>(For PPO installations, refer to TMS Accessory Quality Shipping Standard.)</p>