

Preparation

Part Number: PT747-35050 (B-cab)
PT747-35051 (C-cab)
PT747-35052 (D-cab)

NOTE: Part number of this accessory may not be the same as the part number shown.

Kit Contents

Item #	Quantity Req'd.	Description
1	2	Tacoma Door Sill Protector Front Door (B, C & D Cab)
2*	2	Tacoma Door Sill Protector Rear Door (C & D Cab Only)
3	1	Installation Instructions

Hardware Bag Contents

Item #	Quantity Req'd.	Description
1		

Additional Items Required For Installation

Item #	Quantity Req'd.	Description
1		

Conflicts

--

Recommended Tools

Personal & Vehicle Protection	Notes
None	
Special Tools	Notes
Squeegee	Felt Block (3M) P/N 71606
Surface Thermometer	Infrared Non-contact
Heat Gun	Master Heat Gun HG-301A or equivalent
Installation Tools	Notes
Lint Free Rags	
Nylon Panel Removal Tool	e.g. Panel Pry Tool #1 Toyota SST # 00002-06001-01
Special Chemicals	Notes
Cleaner	3M™ Prep Solvent-70

General Applicability

Tacoma B, C, and D-cab.

Recommended Sequence of Application

Item #	Accessory
1	

*Mandatory

Vehicle Service Parts (may be required for reassembly)

Item #	Quantity Req'd.	Description
1		

Legend

 **STOP:** Damage to the vehicle may occur. Do not proceed until process has been completed with.

 **OPERATOR SAFETY:** Use caution to avoid risk of injury.

 **CAUTION:** A process that must be carefully observed in order to reduce the risk of damage to the accessory/vehicle and to ensure a quality installation.

 **TOOLS & EQUIPMENT:** Used in Figures calls out the specific tools and equipment recommended for this process.

Care must be taken when installing this accessory to ensure damage does not occur to the vehicle. The installation of this accessory should follow approved guidelines to ensure a quality installation.

These guidelines can be found in the "Accessory Installation Practices" document.

This document covers such items as:-

- Vehicle Protection (use of covers and blankets, cleaning chemicals, etc.).
- Safety (eye protection, rechecking torque procedure, etc.).
- Vehicle Disassembly/Reassembly (panel removal, part storage, etc.).
- Electrical Component Disassembly/Reassembly (battery disconnection, connector removal, etc.).

Please see your Toyota dealer for a copy of this document.

1. Installation Temperature.



- (a) Part and vehicle surface temperature must be maintained between 65°F and 90°F for optimum installation. Store parts flat at room temperature in a clean dry place.

2. Clean the Vehicle Surface.

- (a) Carefully remove Door Scuff Plates using NRT.
- (b) Clean the entire application surface to remove grease and wax. Use 3M™ Prep Solvent-70 and clean lint free rag.
- (c) When cleaning with 3M™ Prep Solvent-70.



- (1) Always use a clean (lint free scratch resistant) soft cloth (or wipe), and clean a small area at a time (~3 ft. x 3 ft. max.).

- (2) Shake well.



- (3) Apply 3M™ Prep Solvent-70 to cloth or wipe. Do not spray cleaning solution directly on any vehicle surfaces.

- (4) Clean surface thoroughly and wipe dry immediately with a new clean cloth. Do not allow cleaner to air dry.

3. Installation of the Front Door Sill Protectors.

- (a) Choose correct front door sill protector. (Part names and cab styles are identified on part).

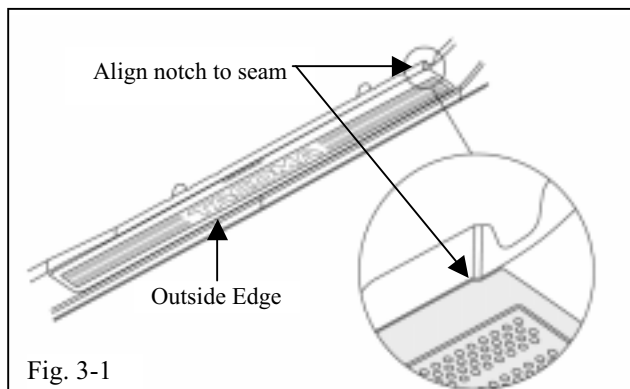

Fig. 3-1

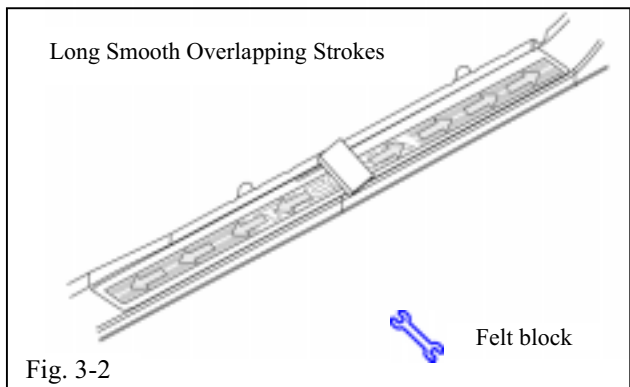

Fig. 3-2

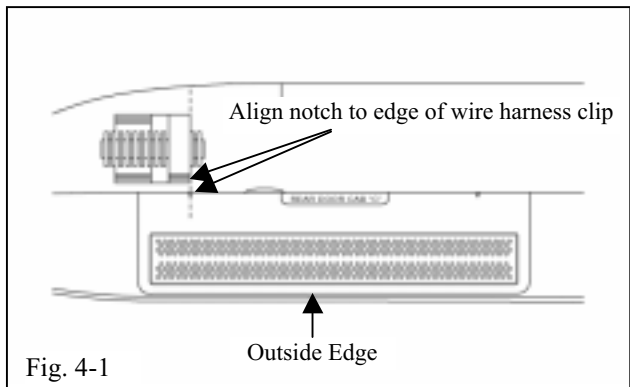

Fig. 4-1

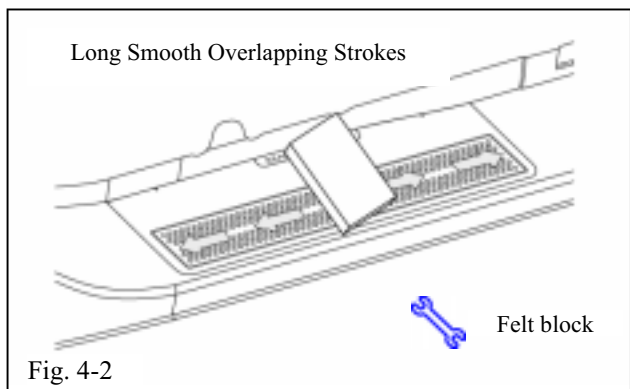

Fig. 4-2

(1) The door sill protectors are not handed (left-hand and right-hand are universal.)

(b) Carefully remove entire paper liner.



(c) Align the front notch to the seam notch in the sheet metal flange and the back edge along the tangent of sheet metal flange. Do not smooth part with hands. Do not let part wrap past outside edge of radius. (Fig. 3-1).

(d) Using a felt block, squeegee the protector to the vehicle with long smooth overlapping strokes starting in the center working out to each end. (Fig. 3-2).

(e) Replace scuff plate.

4. Installation of the Rear Door Sill Protectors

(a) Choose correct rear door sill protector. (Part names and cab styles are identified on part). Left-hand and right-hand are universal. Carefully remove entire paper liner.



(b) Align the rear notch to edge of wire harness clip and the back edge along the tangent of sheet metal flange. Do not smooth part with hands. Do not let part wrap past outside edge of radius. (Fig. 4-1).

(c) Using a felt block, squeegee the protector to the vehicle with long smooth overlapping strokes starting in the center working out to each end. (Fig. 4-2).

(d) Replace scuff plate.

TOYOTA TACOMA 2005 - DOOR SILL PROTECTORS
Checklist - these points **MUST** be checked to ensure a quality installation.

Check:

Accessory Function Checks

- Proper adhesion Visual
-  Proper adhesion Physical

- Proper alignment cross car

Look For:

Look for bubbles, loose and lifting edges.

With light pressure rub hand over top of protector and if crackling sound occurs, resqueegee. (Heating surface to minimum temperature may be required.)

Protector must not wrap past outer edge of radius.