

**Part Number: PT747-08100-DS**

Section I - Installation Preparation

**Kit Contents**

Item #	Quantity Req'd.	Description
1	1	Sienna Door Sill Applique RH
2	1	Sienna Door Sill Applique LH

**Hardware Bag Contents**

Item #	Quantity Req'd.	Description
1		

**Additional Items Required For Installation**

Item #	Quantity Req'd.	Description
1		

**Conflicts**

Note:

**Recommended Tools**

<b>Safety Tools</b>	
None	
<b>Special Tools</b>	
Squeegee	# Felt Block (3M™) P/N 71606
<b>Installation Tools</b>	
Lint Free Rags	
<b>Special Chemicals</b>	
Cleaner	3M™ Prep Solvent-70

# Available through local automotive paint supply stores.

**General Applicability**





Note:

**Recommended Sequence of Application**

Item #	Accessory
1	
2	
3	

\*Mandatory

**Legend**

	<b>STOP:</b> Damage to the vehicle may occur. Do not proceed until process has been complied with.
	<b>OPERATOR SAFETY:</b> Use caution to avoid risk of injury.
	<b>CRITICAL PROCESS:</b> Proceed with caution to ensure a quality installation.
	<b>GENERAL PROCESS:</b> This highlights specific processes to ensure a quality installation.
	<b>TOOLS &amp; EQUIPMENT:</b> Calls out the specific tools and equipment recommended for this process.

Section II - Installation Procedure

**A. Installation Temperature.**



1. Part and vehicle surface temperature must be between 65°F and 90°F for optimum installation. Store parts flat at room temperature in a clean dry place.

**B. Clean the Vehicle Surface.**



1. Clean the entire application surface to remove grease and wax. Use 3M™ Prep Solvent-70 and clean lint free cloth.
  - i. When cleaning with 3M™ Prep Solvent-70 follow the manufacturer's directions. Do not allow cleaner to air dry.

**C. Installation of the Front Left Door Sill Applique.**

1. Carefully remove the entire paper liner starting at the removal tab from Left Hand part (which has "L" stamped on tab.) Avoid excessive finger contact with the adhesive surface.
2. Hold applique taut from each end and carefully work under left hand door seal.



- i. Align the outside border (grain separation line) of the applique visually directly below outer edge of door seal. (Fig.C-1)



- ii. Align rear edge of applique with rear of scuff plate. (Fig.C-2)

3. Do not press applique down with fingers.



4. Using a felt block, squeegee the applique to the vehicle on the horizontal surface starting in the center and working out to each end with smooth overlapping strokes. (Fig. C-2)

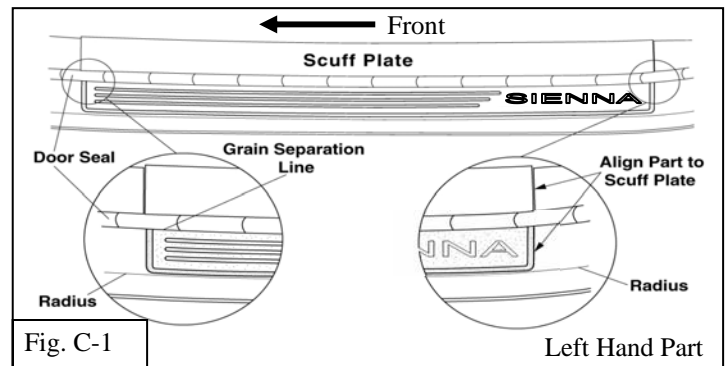

Fig. C-1

Left Hand Part

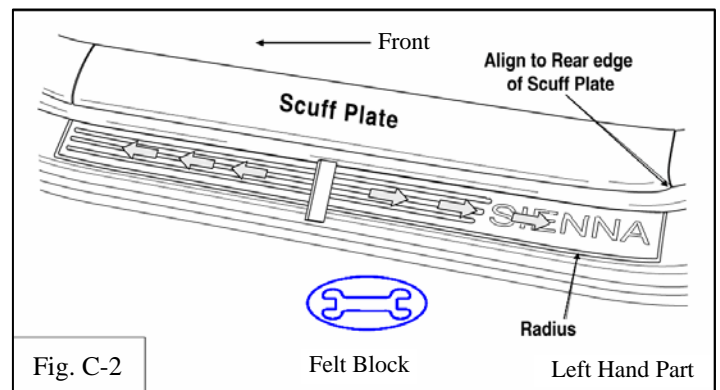

Fig. C-2

Felt Block

Left Hand Part

**D. Installation of the Front Right Door Sill Applique.**

1. Repeat Steps C. 1. through C. 4. for Right Hand part (which has "R" stamped on tab.) (Fig. D-1)

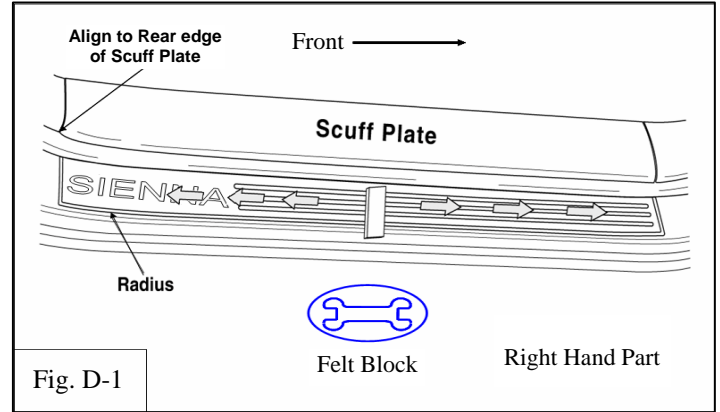

Section III - Functional Verifications

Check: \_\_\_\_\_

- Proper adhesion - Visual
- Proper adhesion – Physical

Look For: \_\_\_\_\_

Look for bubbles & loose edges

Check for gaps in corners with fingernails. If present, resqueegee. With light pressure rub hand over top of applique and if crackling sound occurs, resqueegee. (Heating surface to minimum temperature may be required.)