

Part Number: Mounting Kit PT546-52096
Tuner Assy 86180-0W031

NOTE: Part number of this accessory may not be the same as the part number shown.

Tuner Assy Kit Contents (86180-0W031)

Item #	Quantity Req'd.	Description
1	1	Tuner Assy, Stereo Component

Mounting Kit Contents (PT546-52096)

Item #	Quantity Req'd.	Description
1	1	Ground Cable
2	1	Wire, To Radio Installation
3	2	Tuner Bracket
4	2	Base Bracket
5	1	Template (to locate base bracket)
6	4	Cushion (Butyl)
7	1	Antenna
8	3	Hardware Bags
9	1	XM Satellite Radio Brochure
10	1	Cover

Hardware Bag Contents – 1 (PT546-52096)

Item #	Quantity Req'd.	Description
1	4	Bolt (M5 × L8)
2	4	Nut (M6)

Hardware Bag Contents – 2 (PT546-52096)

Item #	Quantity Req'd.	Description
1	17	Lock Tie (AVC-LAN)
2	1	Cushion Tape (100 × 50mm)
3	9	Sheet Tape B (30 × 30 mm)

Hardware Bag Contents – 3 (PT546-52096)

Item #	Quantity Req'd.	Description
1	4	Cushion Tape (30 × 30 mm)
2	3	Cable Rail (10 mm)
3	1	Cable Rail (50 mm)
4	9	Sheet Tape A (30 × 30 mm)
5	1	Protective Sheet (15 × 540mm)
6	2	Protective Sheet (15 × 70mm)
7	3	Protective Sheet (15 × 50mm)

Additional Items Required For Installation

Item #	Quantity Req'd.	Description
1	1	Satellite Receiver Cover P/N PT218-52071

Conflicts

iPod Interface, Sirius Satellite Radio
--

Recommended Tools

Personal & Vehicle Protection	Notes
Safety Goggles	
Seat Covers	
Floor Protectors	
Special Tools	Notes
Arch (Carpet) Punch	5/16" Hole Diameter
Installation Tools	Notes
Ratchet	
Extensions	
Sockets	8 mm, 10 mm
Torx Socket	E10
Torque Wrench	4.1 N•m (36 lbf•in): Battery cable, 37 N•m (27 lbf•ft): Front Seat
Screwdriver	Phillips, #2
Panel Removal Tool	e.g. Panel Pry Tool #1 Toyota SST # 00002-06001-01
Masking Tape	(2" wide)
Utility Knife	
Side Cutter	
Marking Pen	
Special Chemicals	Notes
Sealant	3M™ Ultra-Pro Body Sealant
Cleaner	3M™ Prep Sol-70

General Applicability

--

Recommended Sequence of Application







Item #	Accessory

*Mandatory

Vehicle Service Parts (may be required for reassembly)

Item #	Quantity Req'd.	Description

Legend

	STOP: Damage to the vehicle may occur. Do not proceed until process has been complied with.
	OPERATOR SAFETY: Use caution to avoid risk of injury.
	CAUTION: A process that must be carefully observed in order to reduce the risk of damage to the accessory/vehicle and to ensure a quality installation.
	TOOLS & EQUIPMENT: Used in Figures calls out the specific tools and equipment recommended for this process.
	REVISION MARK: This mark highlights a change in installation with respect to previous issue.
	SAFETY TORQUE: This mark indicates that torque is related to safety.

Parts Description of Receiver Assembly Radio Unit (86180-0W031)

Item #	Parts Name	Parts No.	Qty
1	Tuner Assy, Stereo Component* ¹	86180-0W031	1

*¹: In the installation instructions and figures, this is referred to as “Tuner”.

Parts Description of Mounting Kit (PT546-52096)

Item #	Parts Name	Qty	
1	Ground Cable	1	
2	Wire, To Radio Installation* ²	1	
3	Tuner Bracket	2	
4	Base Bracket	2	
5	Template (to locate base bracket)	1	
6	Cushion (Butyl)	4	
7	Bolt	4	
8	Nut	4	
9	Lock Tie	17	
10	Cushion Tape (100 mm × 50 mm)	1	
11	Sheet Tape B (30 mm × 30 mm)	9	
12	Cover	1	
13	A	Antenna	1
	B	Cushion Tape (30 mm × 30 mm)	4
	C	Cable Rail (L = 10 mm)	3
	D	Cable Rail (L = 50 mm)	1
	E	Sheet Tape A (30 mm × 30 mm)	9
	F	Protective Sheet (15 mm × 50 mm)	3
	G	Protective Sheet (15 mm × 70 mm)	2
	H	Protective Sheet (15 mm × 540 mm)	1

*²: In the installation instructions and figures, this is referred to as “Tuner Cable”.

Care must be taken when installing this accessory to ensure damage does not occur to the vehicle. The installation of this accessory should follow approved guidelines to ensure a quality installation.

These guidelines can be found in the "Accessory Installation Practices" document.

This document covers such items as:-

- Vehicle Protection (use of covers and blankets, cleaning chemicals, etc.).
- Safety (eye protection, rechecking torque procedure, etc.).
- Vehicle Disassembly/Reassembly (panel removal, part storage, etc.).
- Electrical Component Disassembly/Reassembly (battery disconnection, connector removal, etc.).

Please see your Toyota dealer for a copy of this document.

NOTES



Removed Parts: -

Place all removed parts on a protected surface.



Connectors: -

When disconnecting connectors, do not pull on the wires; pull on the connectors.



Lock Ties: -

When using lock ties to secure harness, clip the lock ties after securing them.



Machine Screws: -

Start all machine screws by hand.



When disconnecting a yellow connector for the SRS airbag, wait 90 seconds or more after disconnecting the negative battery cable before performing the next task.

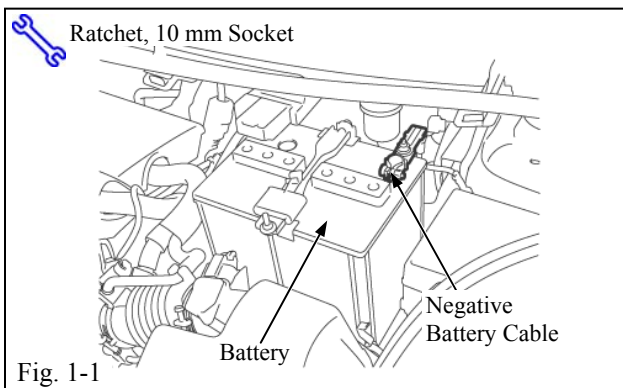

1. Vehicle Protection.

(a) Remove the negative battery cable. (Fig. 1-1)



(1) Protect the fender before starting.



(2) Do not touch the positive terminal with any tool when removing cable.

(b) Check kit contents.

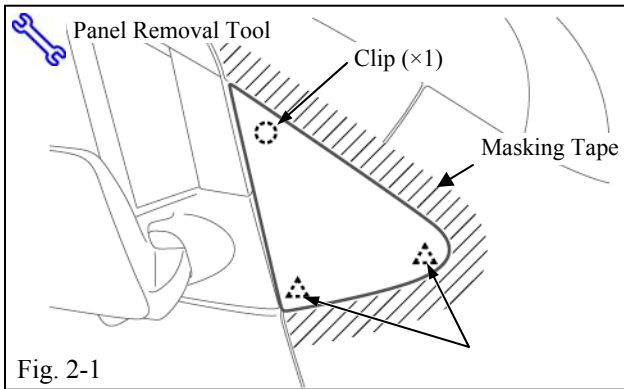

2. Disassembly of Vehicle.

(a) Apply masking tape to vehicle (Fig. 2-1)



(b) Open the passenger door and disengage the two (2) claws and one (1) clip and remove the passenger side mirror cover. (Fig. 2-1)



NOTE: The cover in front of the passenger side mirror of the Hatchback model cannot be reused. Install the new cover from the kit to complete the process after installation is completed.

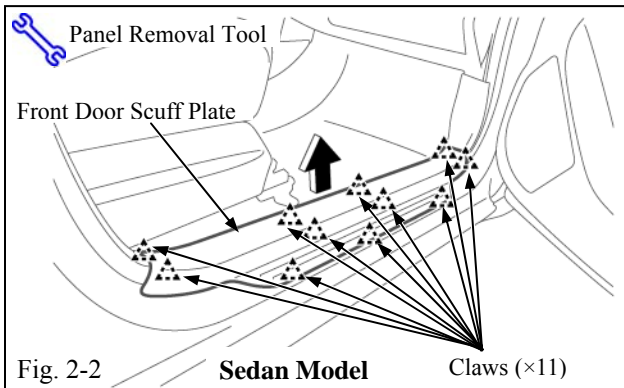

(c) Remove the front door passenger side door scuff plate.

<Sedan>

(1) Disengage the eleven (11) claws and remove the front passenger side door scuff plate. (Fig. 2-2)

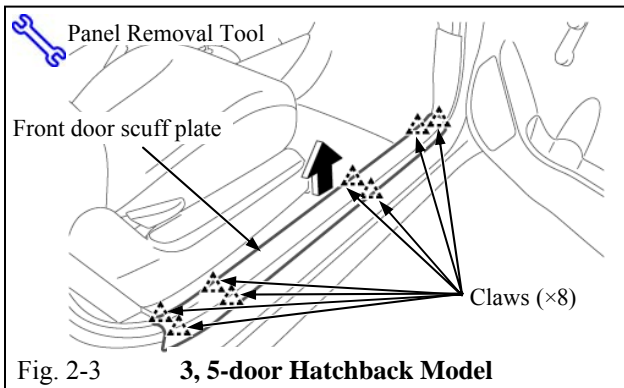

<3, 5-door Hatchback>

(1) Disengage the eight (8) claws and remove the front passenger side door scuff plate. (Fig. 2-3)

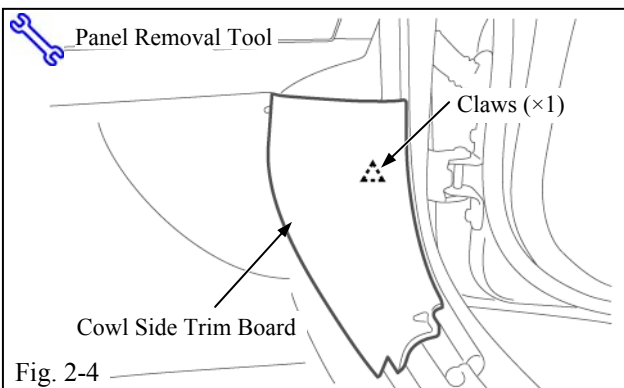

(d) Disengage the one (1) claw, then remove the passenger side cowl side trim board. (Fig. 2-4)

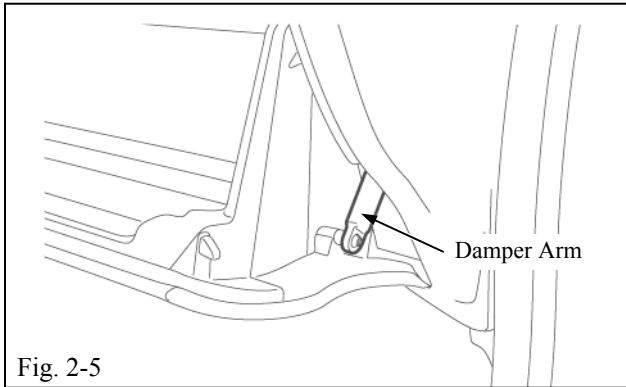

Fig. 2-5

- (e) Remove the glove box door.
 - (1) Remove damper arm from glove box door. (Fig. 2-5)

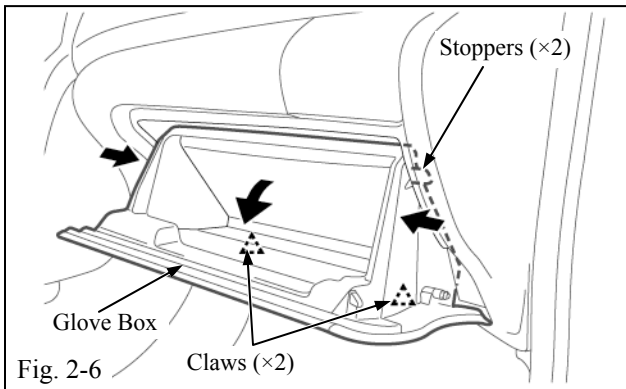
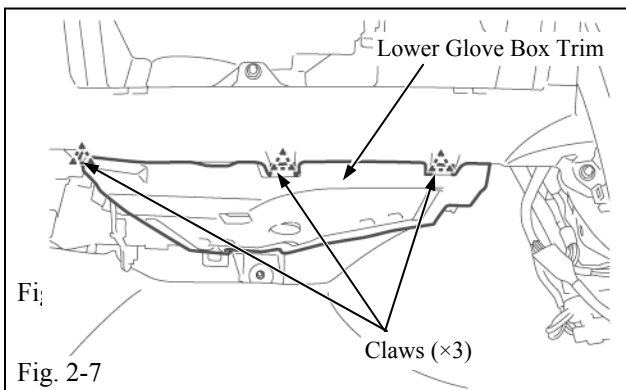

Fig. 2-6

- (2) Release glove compartment stoppers by pressing both glove box side panels inward. (Fig. 2-6)
- (3) Swing glove box toward you; then remove glove box from two (2) claws as shown. (Fig. 2-6)



Fi

Fig. 2-7

- (f) Disengage the three (3) claws to remove the lower glove box trim. (Fig. 2-7)

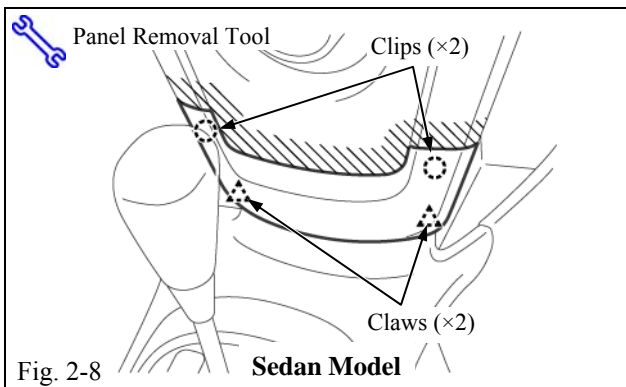

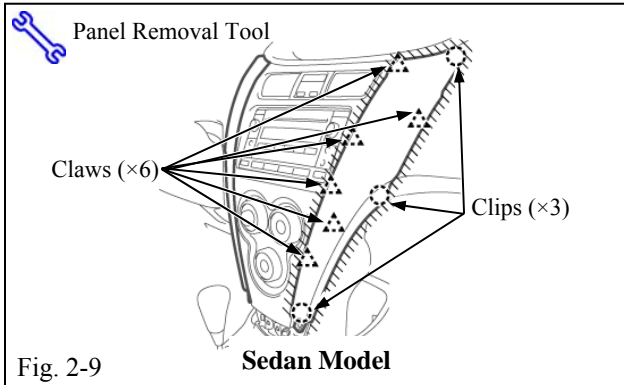

Fig. 2-8

Sedan Model

-  (g) Carefully disengage the two (2) clips and two (2) claws, and remove the lower center finish piece. (Sedan Only) (Fig. 2-8)



(h) Carefully remove the side trim panels.

<Sedan>

- (1) Disengage the three (3) clips and six (6) claws on each side and remove the side trim panels. (Fig. 2-9)

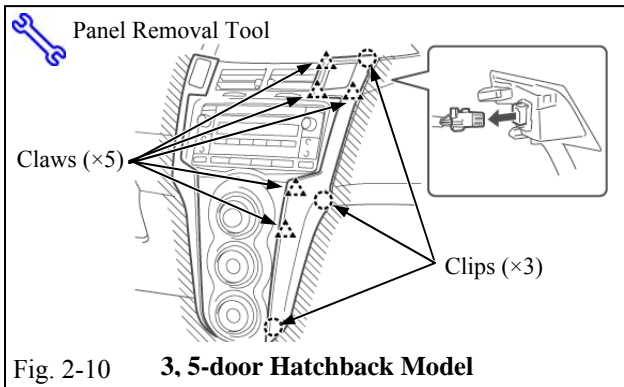

<3, 5-door Hatchback>



- (1) Carefully disengage the three (3) clips and five (5) claws on each side and remove the side trim panels. Make sure to disconnect electrical harness at the top of the each side trim panels. (Fig. 2-10)

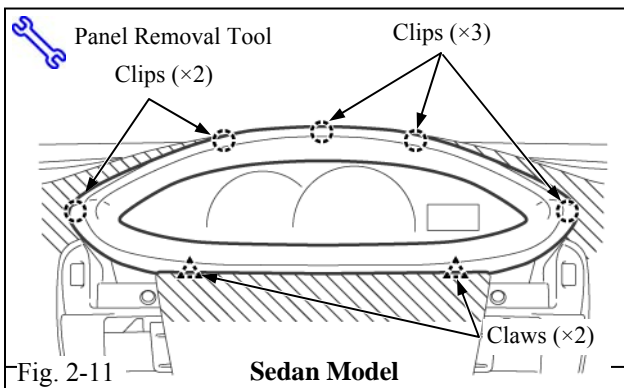

(i) Carefully remove the instrument cluster finish panel.

<Sedan>

- (1) Disengage the five (5) clips and two (2) claws and then remove the instrument cluster finish panel. (Fig. 2-11)

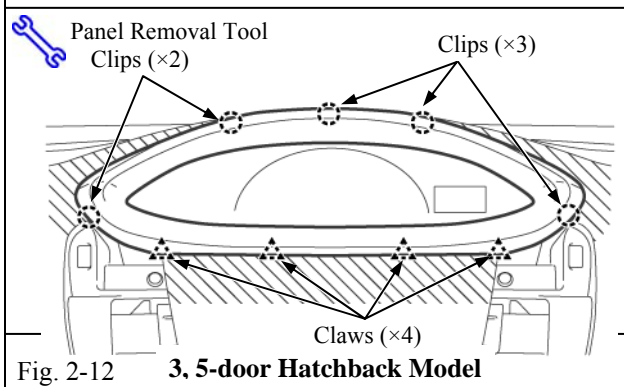

<3, 5-door Hatchback >



- (1) Carefully disengage the five (5) clips and four (4) claws and then remove the instrument cluster finish panel. (Fig. 2-12)

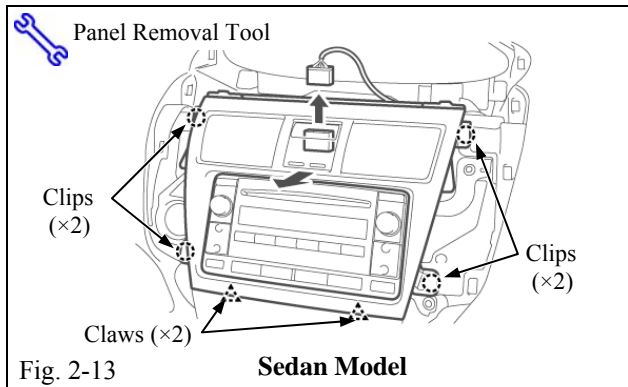

(j) Remove the instrument cluster finish panel.

<Sedan>

- (1) Disengage the four (4) clips and two (2) claws and then remove the instrument cluster finish panel.
 Make sure to disconnect electrical harness at the top of the panel. (Fig. 2-13)

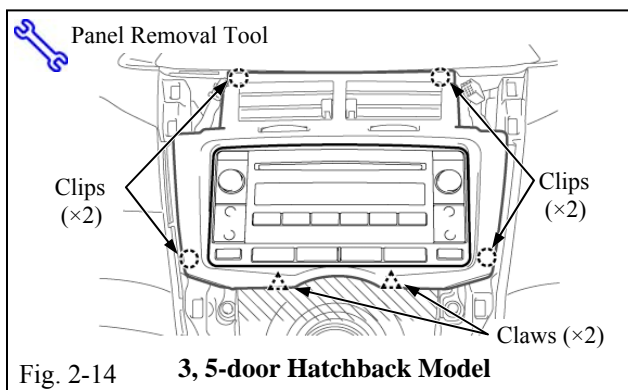

<3, 5-door Hatchback >

- (1) Disengage the four (4) clips and two (2) claws and then remove the instrument cluster finish panel. (Fig. 2-14)

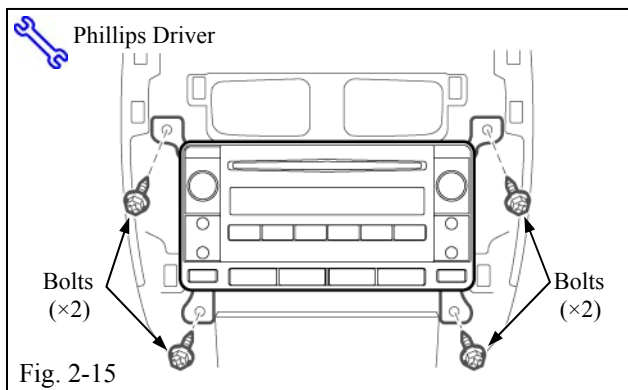

(k) Remove the audio head unit.

- (1) Remove the four (4) screws. (Fig.2-15)
- (2) Pull the audio head unit toward you to remove.

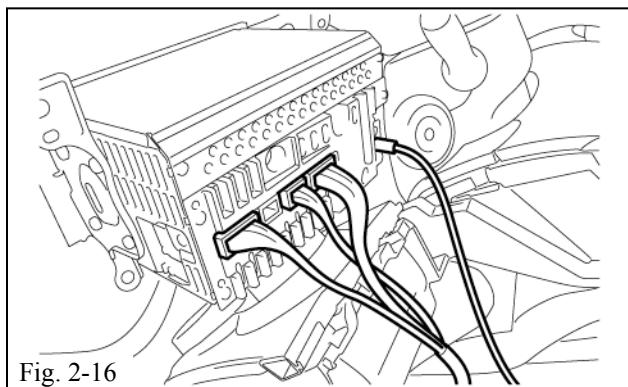

- (3) Disconnect electrical connectors and antenna cable plug from rear of head unit. (Fig. 2-16)

(l) Remove the front passenger seat.

- (1) Remove the headrest.
- (2) Slide the passenger seat rearward.

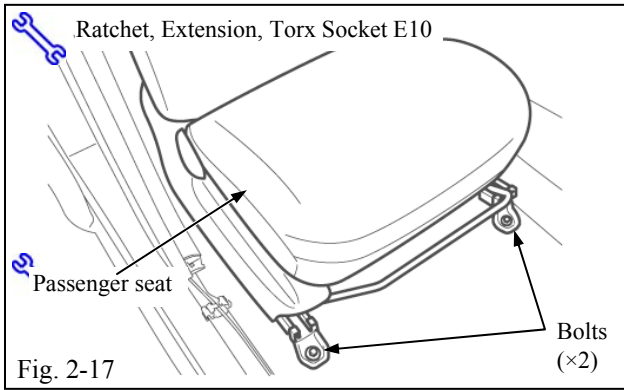

(3) Remove the two (2) bolts on front side.
(Fig. 2-17)

(4) Slide the passenger seat forward.

(5) Remove the two (2) bolts on rear side.
(Fig. 2-18)

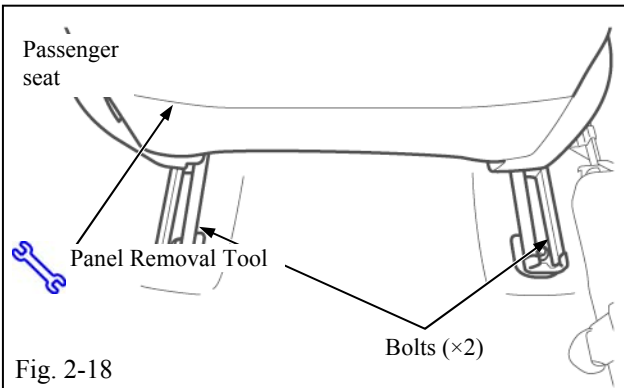

(6) Tilt the seat over towards the rear and remove the three (3) seat electrical connectors. (Fig. 2-19)

⚠ NOTE: Wait 90 seconds or more after disconnecting the negative battery cable to prevent the airbag from deploying.

(7) Remove the seat harness clamp.
(Fig. 2-19)

⚠ NOTE: Be careful not to damage the harness clamp by forcibly removing it.

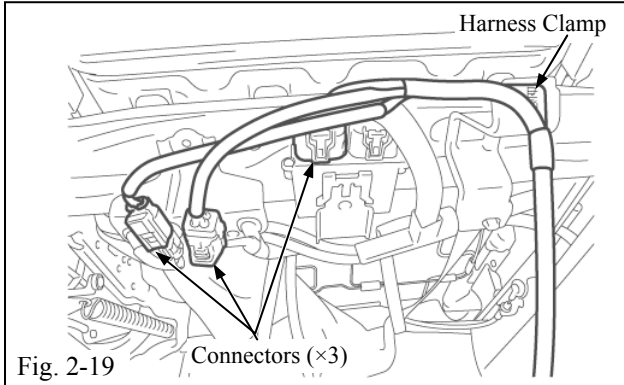

(m) To lift the carpet, release the tabs of the two (2) vehicle clamps at the door sill as shown.
(Fig. 2-20)

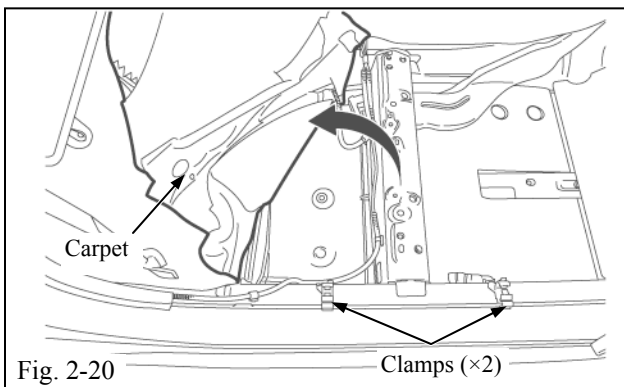

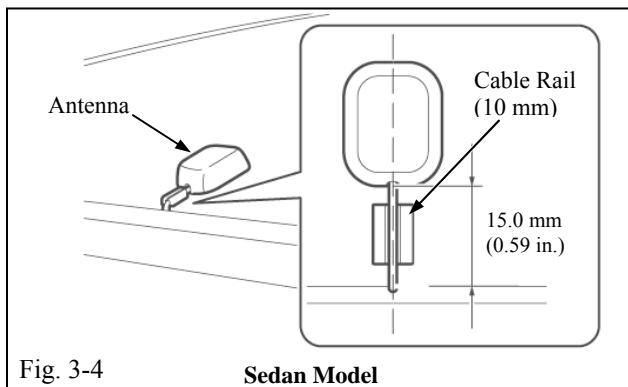
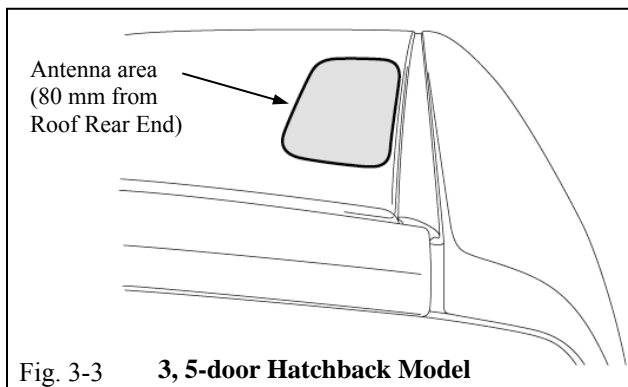
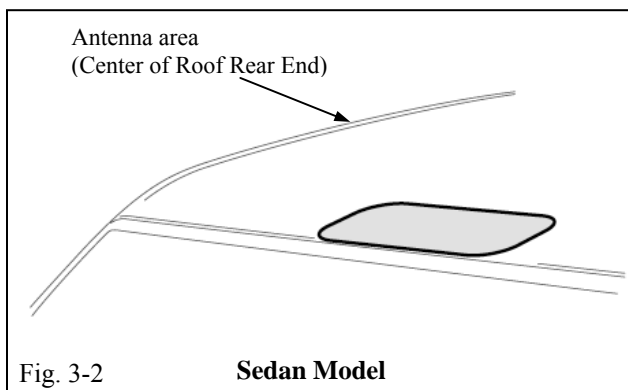
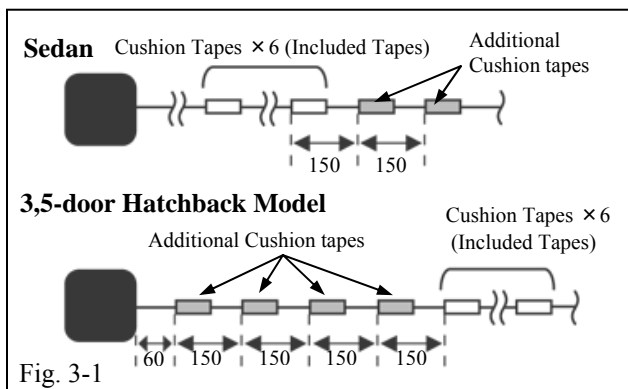

3. Install XM Antenna and Antenna Cable

(a) Preparation prior to the installation

- (1) The antenna cable already has 6 (six) cushion tapes; however, depending on the vehicle type (Sedan, 3 or 5-door Hatchback), additional cushion tapes (30 × 30 mm) are required. Apply cushion tapes as shown. (Fig. 3-1)

(b) Clean the antenna area with 3M™ Prep Sol-70 and cleaning method. (Fig. 3-2, 3-3)

<When cleaning with 3M™ Prep Sol-70>



- (1) Always use a clean (lint free scratch resistant) soft cloth (or wipe), and clean a small area at a time (3 ft. × 3 ft. max.).



- (2) Apply 3M™ Prep Sol-70 to cloth or wipe. Do not spray cleaning solution directly on any vehicle surfaces.

- (3) Clean surface thoroughly and wipe dry immediately with a new clean cloth. Do not allow cleaner to air dry.

(c) Temporarily place the antenna at the position as shown, and confirm the installation position. (Fig. 3-4, 3-5)

(d) Attach the cable rails on the roof as shown. (Fig. 3-4, 3-5)

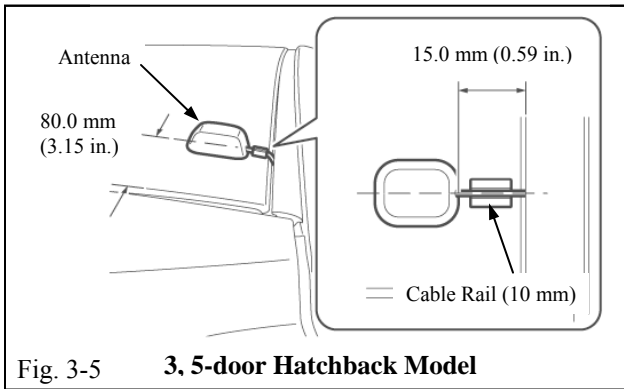

(e) Remove the release paper from the antenna, and then install the antenna from the roof as shown. (Fig. 3-6, 3-7)

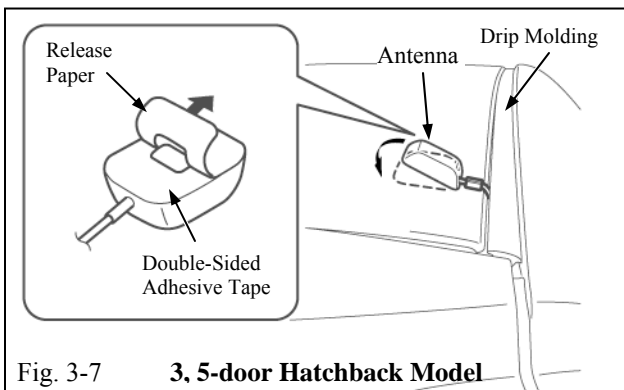
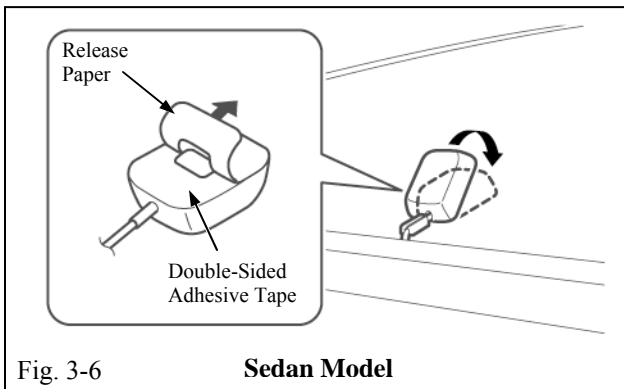

(f) Bury the antenna cable into the rear window weather strip using the panel removal tool. (Sedan only) (Fig. 3-8)

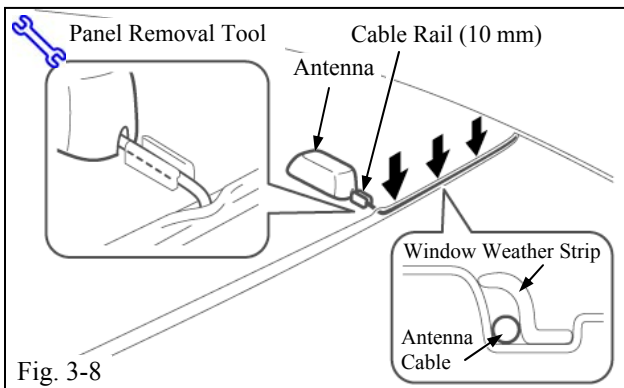

NOTE: Bury the antenna cable all the way into the weather strip.

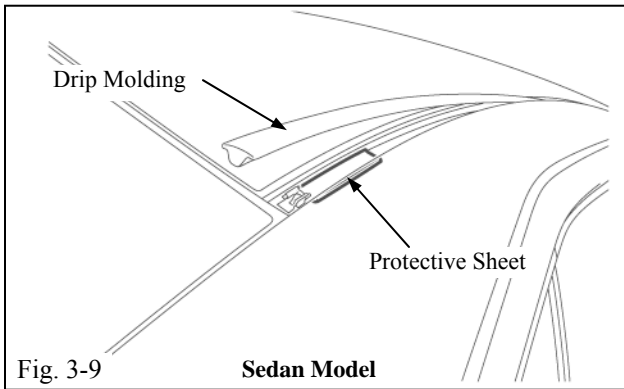

(g) Remove the rear side of drip molding and apply one (1) protective sheet (15 × 70 mm). (Fig. 3-9, 3-10)

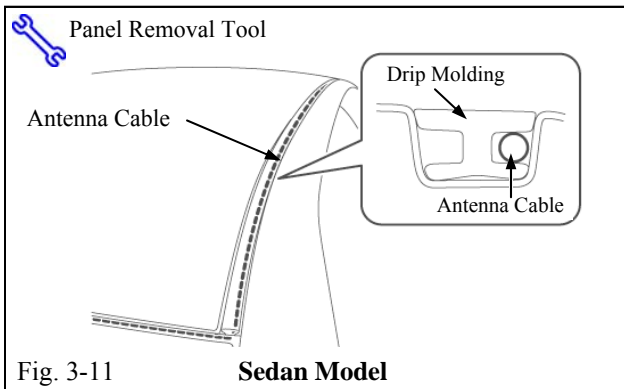
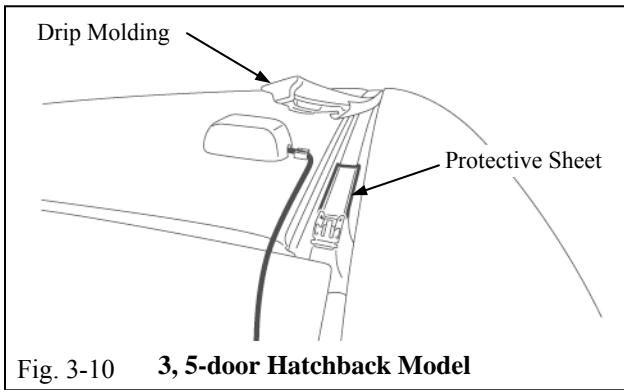

(h) Route the antenna cable as shown under the drip molding using the panel removal tool. (Fig. 3-11, 3-12)

NOTE: Bury the antenna cable all the way into the weather strip.

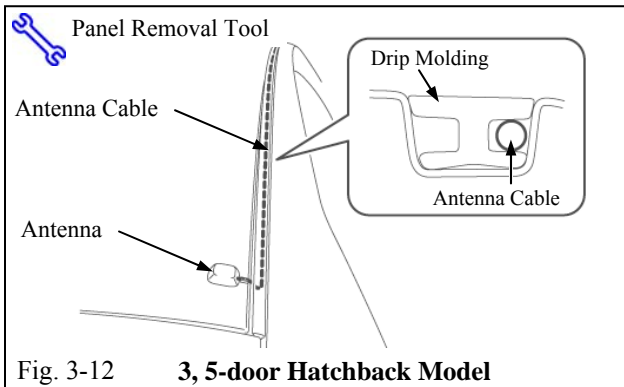

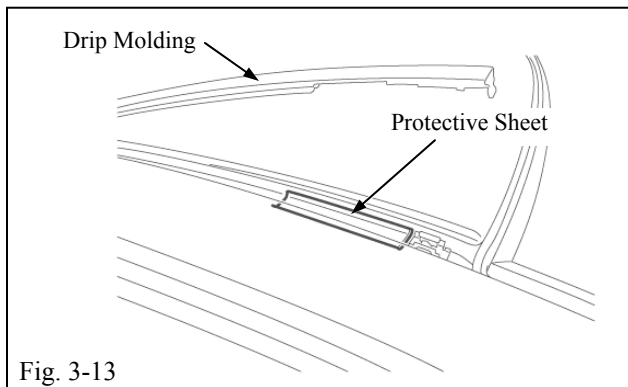

- (i) Remove the front side of drip molding and apply one (1) protective sheet (15 × 70 mm). (Fig. 3-13)

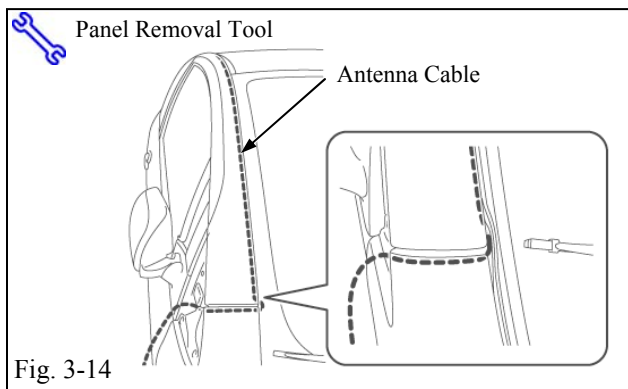

- (j) Bury the antenna cable into the front windshield weather strip using the panel removal tool. (Fig. 3-14)

NOTE:

- Bury the antenna cable all the way into the weather strip.
- Check for any gaps between the weather strip and the windshield.

- (k) Bury the antenna cable into the opening between the pillar and the front fender using the panel removal tool. (Fig. 3-14, 15)

NOTE:

Push the antenna cable behind the front fender.

- (l) Secure the antenna cable to the front portion of the mirror with sheet tape and cable rails. (Fig. 3-15, 3-16)

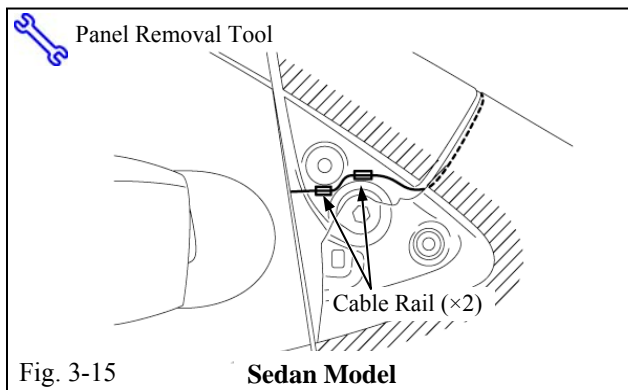

<Sedan>

- (1) Secure the antenna cable to the front area of the mirror using two (2) cable rails (10 mm). (Fig.3-15)

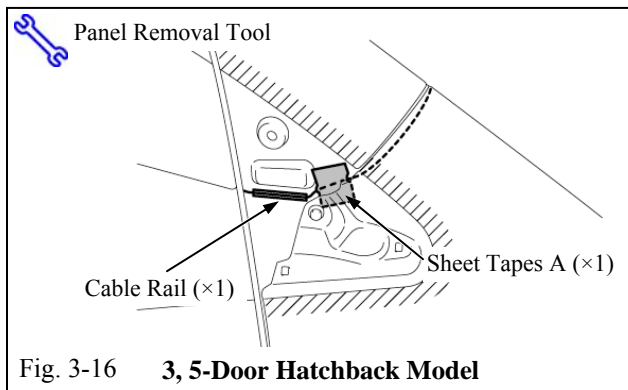

<3, 5-door Hatchback>

- (1) Secure the antenna cable to the front area of the mirror using one (1) sheet tape (30 × 30 mm) and one (1) cable rail (50 mm). (Fig.3-16)

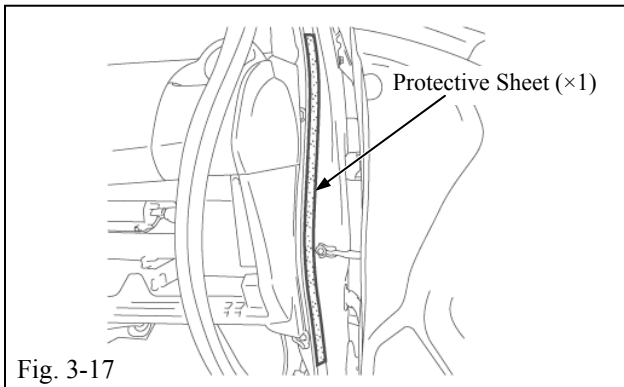

(m) Apply one (1) protective sheet (50 × 540 mm) to the door channel. (Fig. 3-17)

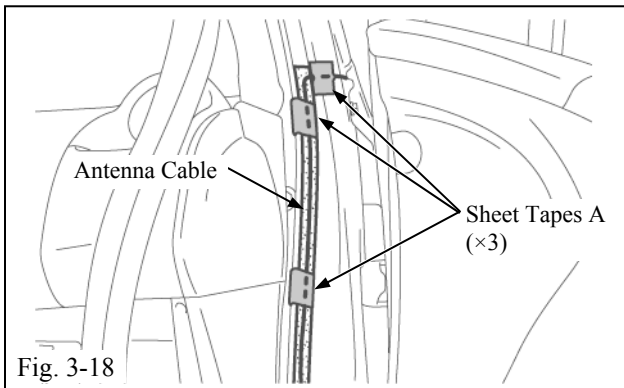

(n) Secure the antenna cable to the door channel using the three (3) sheet tapes (30 × 30 mm) as shown. (Fig. 3-18)

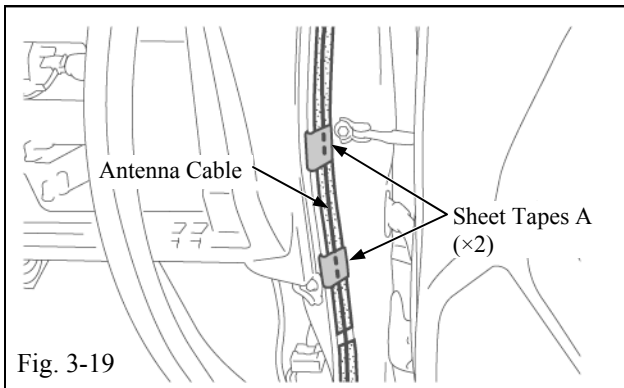

(o) Secure the antenna cable to the lower area of the door channel using two (2) sheet tapes (30 × 30 mm) as shown. (Fig. 3-19)

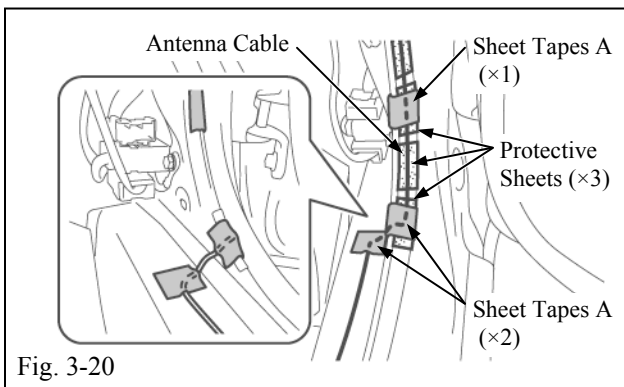

(p) Apply three (3) protective sheets (15 × 50 mm) to the door channel and secure the antenna cable to the door channel using three (3) sheet tapes (30 × 30 mm) as shown. (Fig. 3-20)

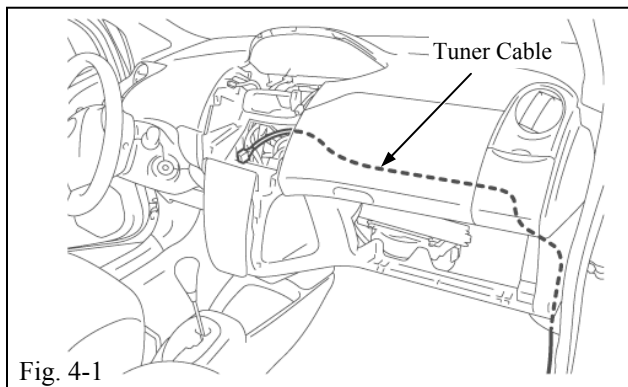

4. Install Tuner Cable

- (a) Install and route the tuner cable from the center cluster, along the reinforcement bar, over the dash mounting bracket, then downward toward the cowl side area. (Fig. 4-1)

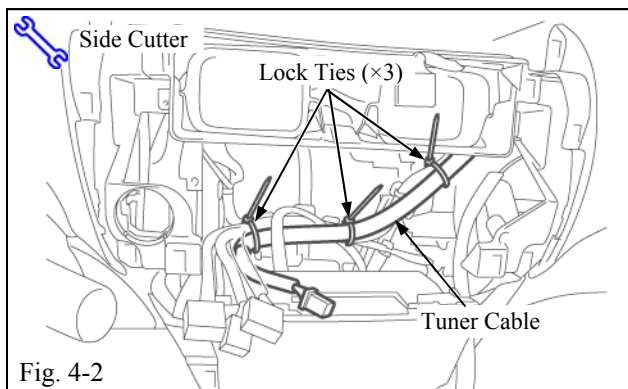

- (a) Route the tuner cable from the center cluster to the glove box side and secure it to the existing wire harness using three (3) lock ties. (Fig. 4-2)

NOTE: Cut excess lock ties length with side cutter.

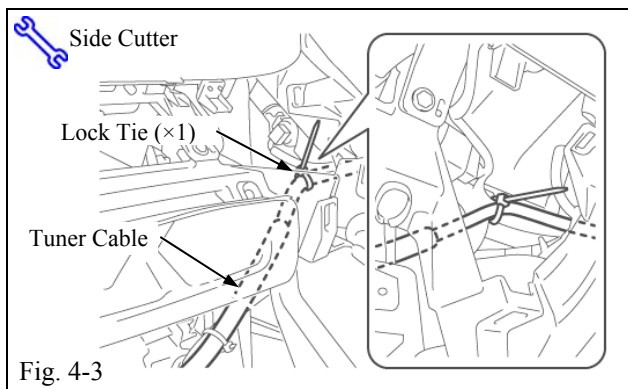

- (b) Secure the tuner cable in the existing harness using one (1) lock tie. (Fig. 4-3)

NOTE: Cut excess lock tie length with side cutter.

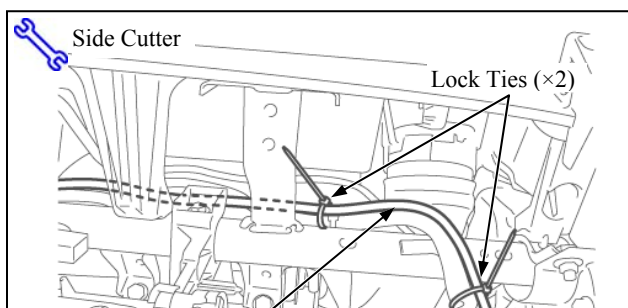

- (c) Secure the tuner cable in the upper area of glove box onto the existing harness using two (2) lock ties. (Fig. 4-4)

NOTE: Cut excess lock ties length with side cutter.

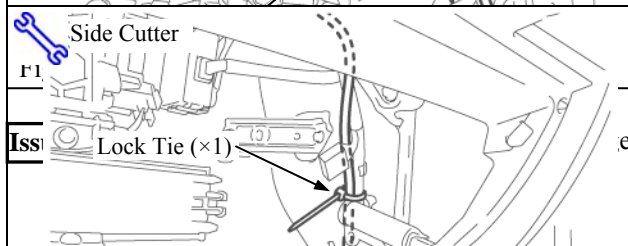

- (d) Secure the tuner cable in the right side area of glove box onto the existing harness using one (1) lock tie. (Fig. 4-5)

 **NOTE:** Cut excess lock tie length with side cutter.

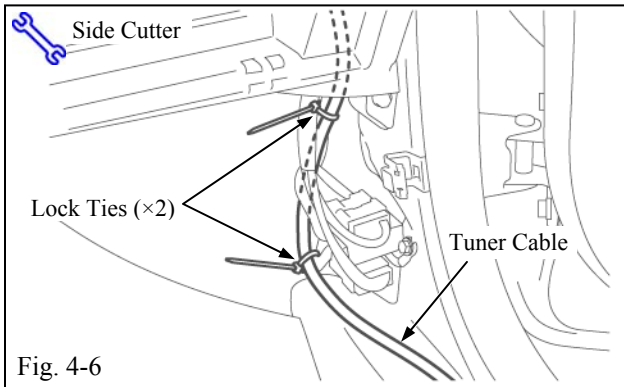

- (e) Secure antenna wire and tuner cable to existing vehicle harness using two (2) lock ties (Fig. 4-6).

 **NOTE:** Cut excess lock ties length with side cutter.

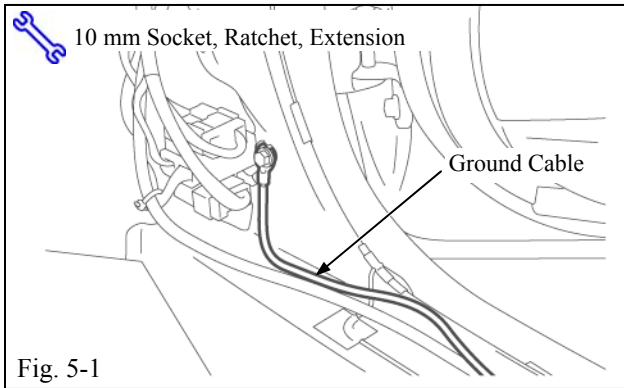

5. Install Ground Cable

- (a) Install the end of the tuner ground cable onto the bolt located on the cowl side. (Fig. 5-1)

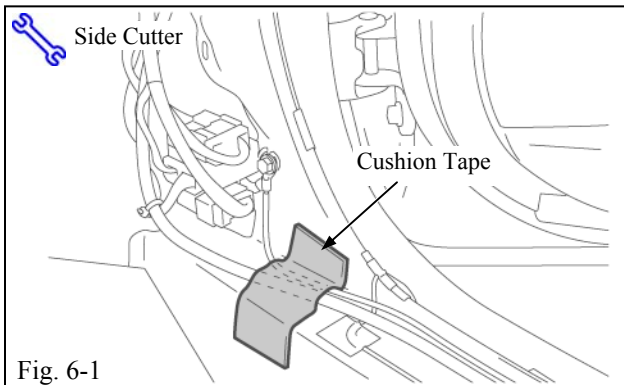

6. Route and Install Tuner, Antenna, Ground Cable

- (a) Bundle the tuner cable and ground cable, and then secure them using the cushion tape (100 × 50 mm). (Fig. 6-1)

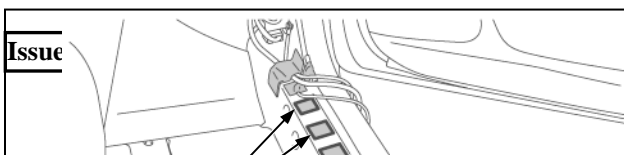

- (b) Apply nine (9) sheet tapes (30 × 30 mm) to the passenger scuff plate channel. (Fig. 6-2)

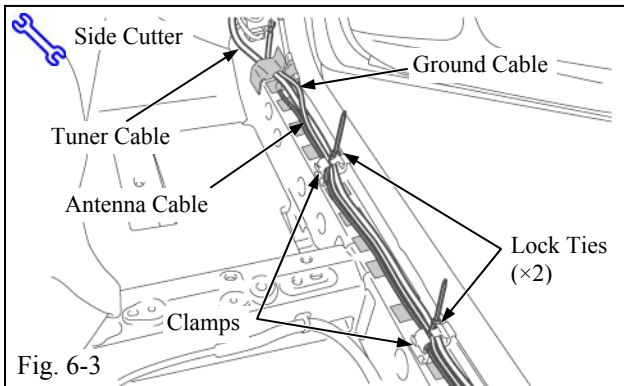

- (c) Route each cable through the existing clamps and secure the cables immediately behind the clamps using two (2) lock ties. (Fig. 6-3)

NOTE: Cut excess lock ties length with side cutter.

7. Install Tuner and Route The Cables

- (a) Install four (4) cushions (butyl) onto the bottom of base brackets. (Fig. 7-1)

NOTE: Clean the base brackets and base bracket mounting area (3M™ Prep Sol-70).

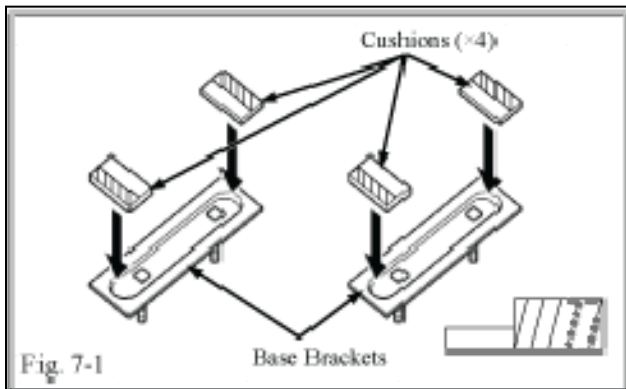

- (b) Run the part of the bolts on the bracket through from the backside of the template, and apply the template to the brackets.
- (c) Place the edge of the template attached to the brackets to the corner of the floor. (Fig. 7-2)
- (d) Apply pressure on the base brackets from above.
- (e) Detach the template from the brackets.

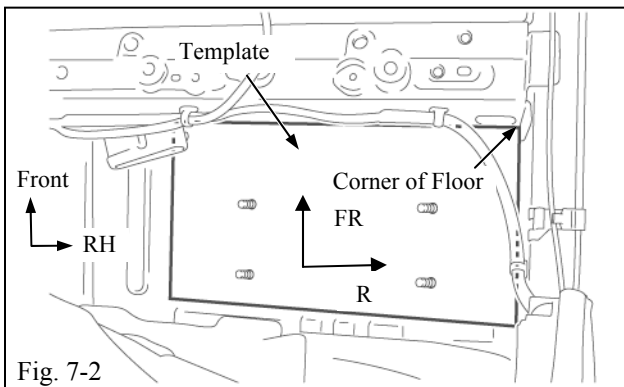

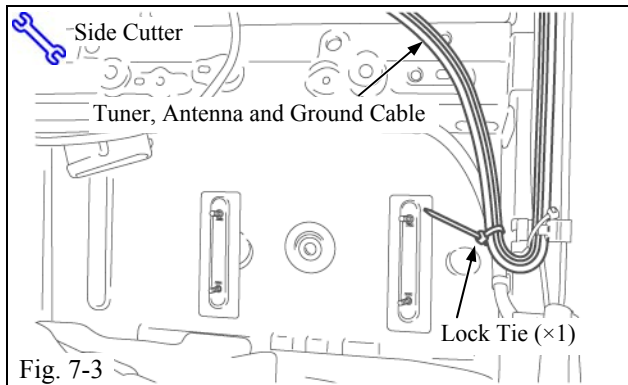

Fig. 7-3

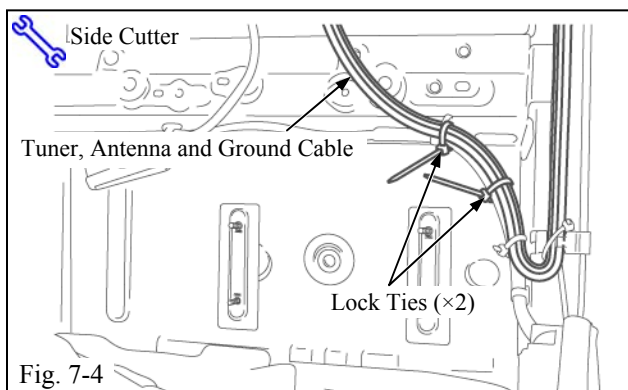

Fig. 7-4

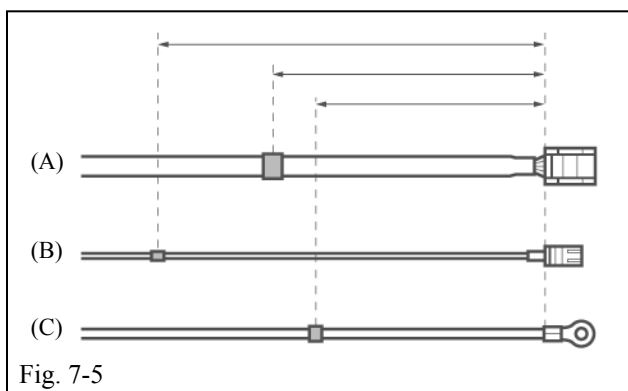

Fig. 7-5

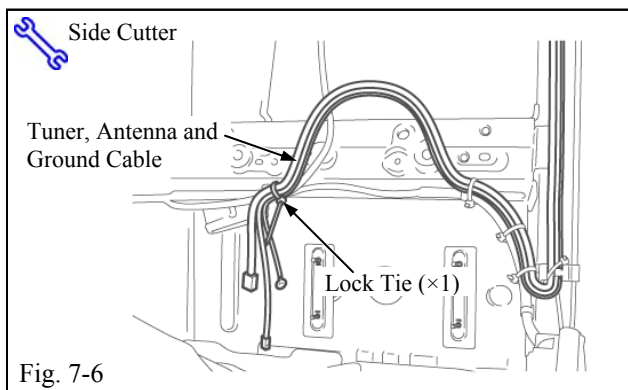

Fig. 7-6

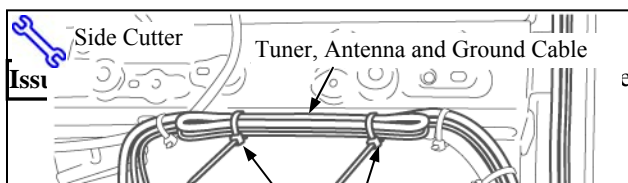

Fig. 7-7

(f) Route the tuner cable, antenna cable, ground cable.

- (1) Tie and secure the cables using one (1) lock tie at the point where the three cables join. (Fig. 7-3)



NOTE: Cut excess lock tie length with side cutter.

- (2) Route the cables as shown and secure them using two (2) lock ties starting from outside. (Fig. 7-4)



NOTE: Cut excess lock ties length with side cutter.

- (3) Mark each of the cables with masking tape as shown in the figure. (Fig. 7-5)

- (A) Tuner cable: 130 mm (5.12 in.)
- (B) Antenna cable: 250 mm (9.84 in.)
- (C) Ground cable: 125 mm (4.92 in.)

- (4) Secure the marked areas of the tuner cable, antenna cable and ground cable to the wire harness with the one (1) lock tie. (Fig. 7-6)



NOTE: Cut excess lock tie length with side cutter.

- (5) Even out the length of the cables and secure the tuner cable, antenna cable and ground cable with the two (2) lock ties. (Fig. 7-7)

⚠ NOTE: Cut excess lock ties length with side cutter.

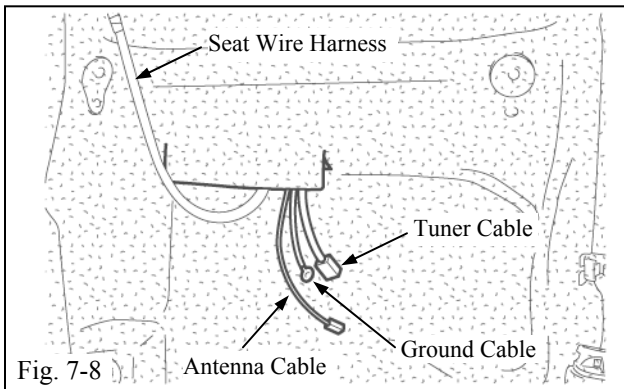

- (g) Route the tuner cable, antenna cable, ground cable, and seat wire harness through the floor carpet hole. (Fig. 7-8)
- (h) Reinstall the floor carpet to the original position.

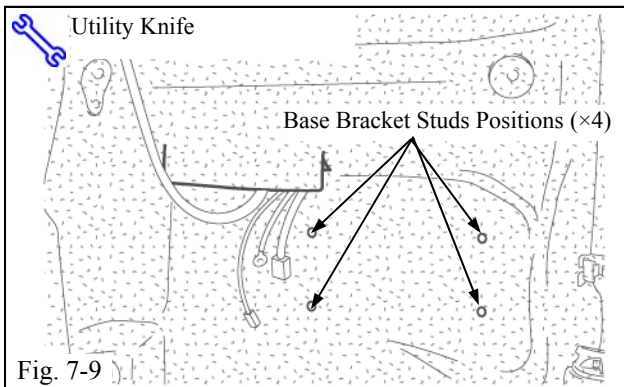

- (i) Verify the base bracket studs positions. Transfer each stud location onto the floor carpet using a marking pen and cut the four (4) holes in floor carpet. (Fig. 7-9)
- (j) Pass the base bracket studs through the carpet.

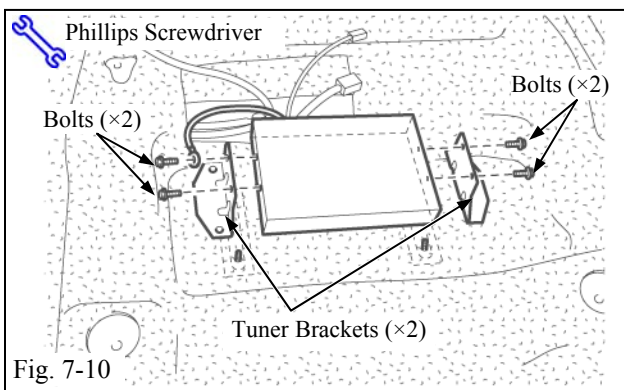

- (k) Install the tuner brackets and ground cable onto the tuner so the connectors face toward the forward of the vehicle. (Fig. 7-10)

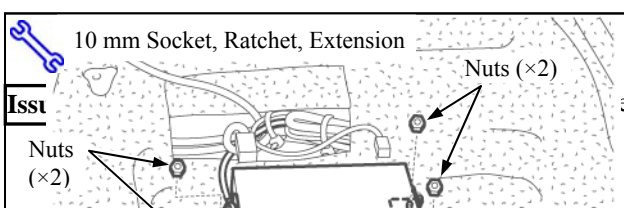

- (l) Secure the tuner onto the base brackets. (Fig. 7-11)

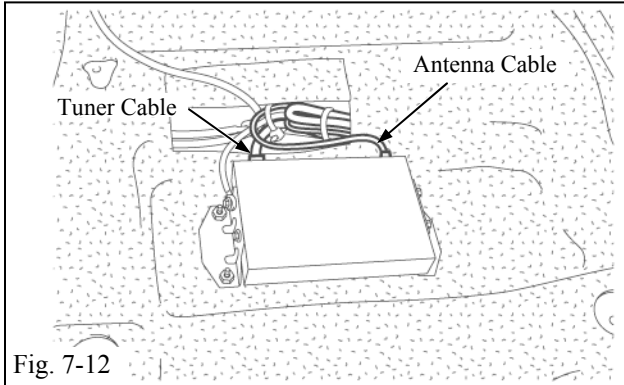

Fig. 7-12

(m) Plug the tuner and antenna cable connectors into the tuner. (Fig. 7-12)

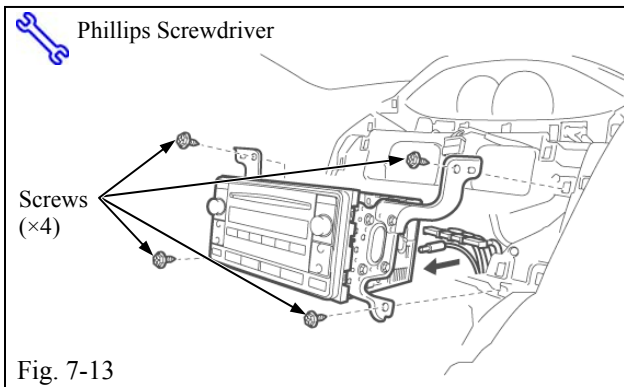

Fig. 7-13

(n) Plug the tuner cable into the head unit, reconnect the factory harness and antenna; then reinstall the audio head unit. (Fig. 7-13)

8. Test SDARS functionality

(a) Temporarily reconnect the negative battery cable. (Fig. 10-4)

+ **CAUTION:** Do not touch the positive terminal with any tool when replacing the cable.

! (b) Test for SDARS functionality.

! (c) After testing for SDARS functionality, disconnect the negative battery cable, then proceed to Vehicle Reassembly.

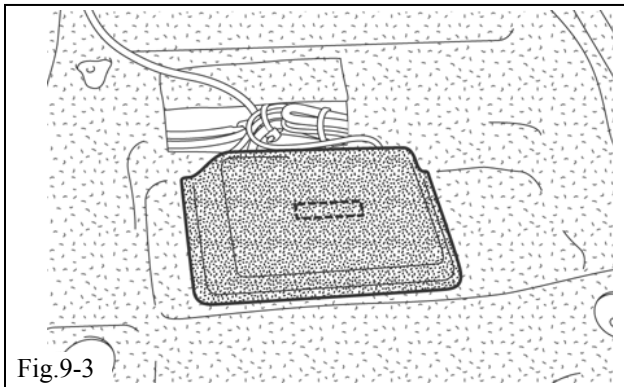
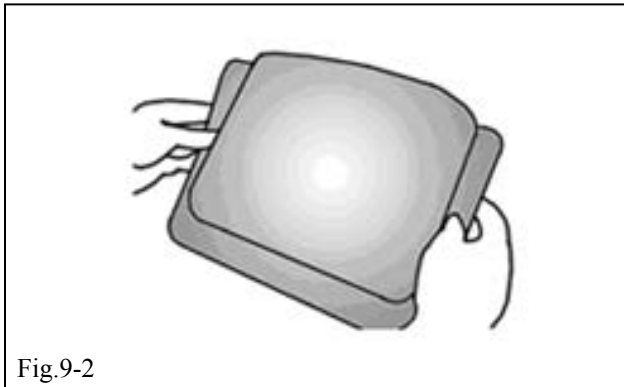
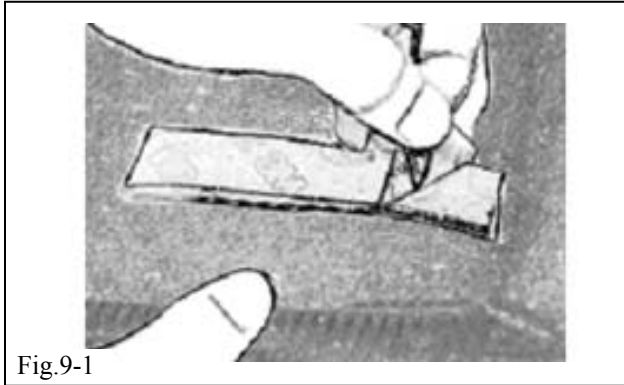

9. Installing Receiver Cover

- (a) Remove the satellite receiver cover (P/N PT218-52071) from the poly bag.
- (b) Shape the cover so that it forms an open box shape with the Velcro™ facing down.

⚠ NOTE: Shipping and storage may have caused the shape to distort.

- (c) Peel the backing off the sewn-in Velcro™ strip inside the cover. (Fig. 9-1).
 - (1) Do not separate the Velcro™.
- (d) Clean the top of satellite receiver box with 3M™ Prep Sol-70.
- (e) Align the rear edge of the cover with the rear edge of the satellite receiver. (Fig. 9-2).
- (f) Center cover to ensure satellite receiver mounting bolts are covered. Press Velcro™ to the floor carpet around the perimeter.
- (g) Press the sewn-in Velcro™ tab on the top underside of the cover firmly to the satellite receiver. (Fig. 9-3).

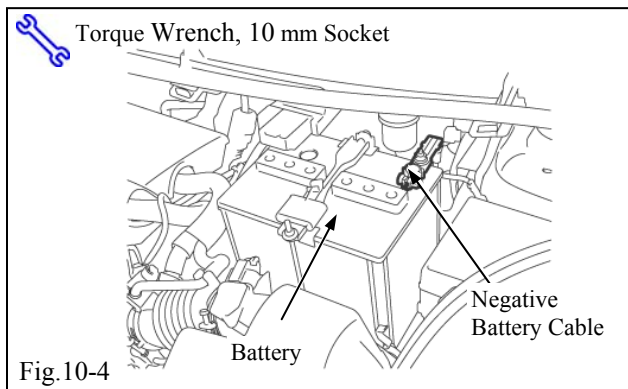
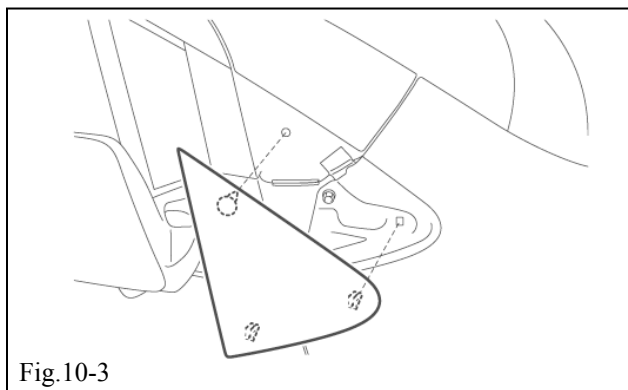
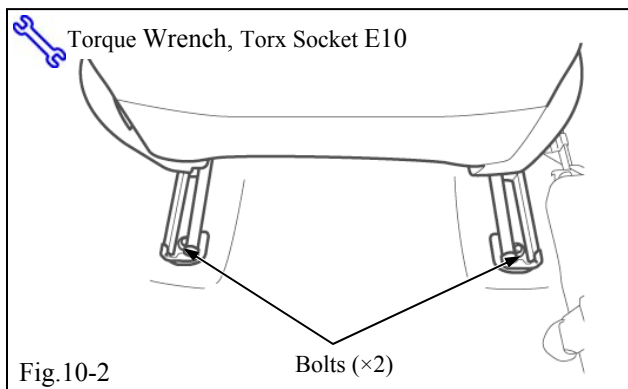
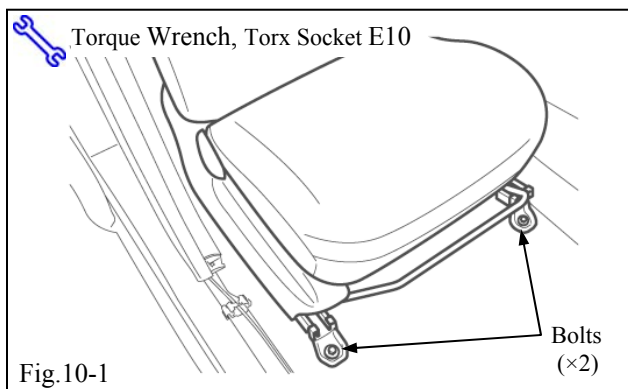

10. Completing the Installation

- (a) Reinstall the front passenger seat.
(Fig. 10-1, 10-2)
 - (1) Reconnect the seat connectors.
 - (2) Reinstall the four (4) bolts loosely, then tighten to specified torque.



Specified Torque: 37 N•m (27 lbf•ft)

- (b) Install the new cover (supplied with kit).
(Fig. 10-3)



- (c) Reconnect any disconnected electrical connectors.



- (d) Verify the panels fit together properly with no uneven gaps between them.

- (e) Clean up and remove any trash.

- (f) Place the owner "XM Satellite Radio" brochure in the glove box.

- (g) Reconnect the vehicle's negative battery cable. (Fig. 10-4)

- (1) Position the negative terminal at the original factory position.



Specified Torque: 4.1 N•m (36 lbf•in)



CAUTION: Do not touch the positive terminal with any tool when replacing the cable.

Checklist - these points **MUST** be checked to ensure a quality installation.

<u>Check:</u>	<u>Look For:</u>
<p><u>Accessory Function Checks</u></p> <p><input type="checkbox"/> Satellite Radio Tuner.</p> <p><input type="checkbox"/> Receiver/player Assembly.</p>	<p>*Verify the proper operation of the Satellite Radio Tuner.</p> <p>*Verify the proper operation of the Receiver/player Assembly</p> <p>*(Refer to the receiver assembly and radio owner's manuals.)</p>
<p><u>Vehicle Function Checks</u></p> <p><input type="checkbox"/> Hazard switch</p> <p><input type="checkbox"/> Passenger's seat belt reminder light</p> <p><input type="checkbox"/> Removed seat</p> <p><input type="checkbox"/> Proper operation of the removed seat lock mechanism</p> <p><input type="checkbox"/> SRS warning light</p> <p><input type="checkbox"/> HVAC (heating ventilation and air conditioning system)</p>	<p>Proper operation of the hazard switch.</p> <p>Proper operation of the passenger's seat belt reminder light.</p> <p>Verify the removed seat is securely fastened</p> <p>Verify the proper operation of the removed seat lock mechanism.</p> <p>Verify the SRS warning light illuminates for approximately 6 seconds with the ignition ON, and then goes out.</p> <p>Verify proper operation of the air conditioning system.</p>