

Preparation

**Part Number: Mounting Kit PT546-52080
Tuner Assy 86180-0W031**

NOTE: Part number of this accessory may not be the same as the part number shown.

Tuner Assy Kit Contents (86180-0W031)

Item #	Quantity Req'd.	Description
1	1	Tuner Assy, Stereo Component

Mounting Kit Contents (PT546-52080)

Item #	Quantity Req'd.	Description
1	1	Ground Cable
2	1	Wire, To Radio Installation
3	2	Tuner Bracket
4	2	Base Bracket
5	1	Template A (to locate base bracket)
6	4	Cushion A (Butyl)
7	1	Antenna
8	3	Hardware Bags
9	1	XM Satellite Radio Brochure

Hardware Bag Contents – 1 (PT546-52080)

Item #	Quantity Req'd.	Description
1	4	Screw (M5xL8)
2	4	Nut (M6)

Hardware Bag Contents – 2 (PT546-52080)

Item #	Quantity Req'd.	Description
1	15	Lock Tie A (AVC-LAN)
2	2	Cushion Tape (50 x 100 mm)

Hardware Bag Contents – 3 (PT546-52080)

Item #	Quantity Req'd.	Description
1	1	Template B
2	1	Connector Housing
3	1	Cushion Tape (20 x 100 mm)
4	8	Lock Tie B (antenna cable)
5	10	Sheet Tape (to fix antenna)
6	1	Cord Rail (30 mm)
7	3	Protective Sheet (20 x 40 mm)

Additional Items Required For Installation

Item #	Quantity Req'd.	Description
1	1	Satellite Receiver Cover P/N PT218-52071

Conflicts

Sirius Satellite Radio

Recommended Tools

Personal & Vehicle Protection	Notes
Safety Goggles	
Seat Covers	
Special Tools	Notes
Arch (Carpet) Punch	5/16 in. Hole Diameter
Installation Tools	Notes
Ratchet	
Extensions	
Sockets	10 mm, 12 mm, 14 mm
Torque Wrench	4.1 N•m (36 lbf•in), 18 N•m (13 lbf•ft), 37 N•m (27 lbf•ft), 42 N•m (31 lbf•ft)
Screwdriver	Philips, #2
Panel Removal Tool	e.g. Panel Pry Tool #1 Toyota SST # 00002-06001-01
Masking Tape	(2 in. wide)
Mallet	
Special Chemicals	Notes
Sealant	3M™ Ultra-Pro Body Sealant
Cleaner	3M™ Prep Solvent 70

General Applicability

--

Recommended Sequence of Application







Item #	Accessory
1	TVIP
2	Satellite Receiver
3	Audio
4	Subwoofer (SB)

*Mandatory

Vehicle Service Parts (may be required for reassembly)

Item #	Quantity Req'd.	Description

Legend

	STOP: Damage to the vehicle may occur. Do not proceed until process has been complied with.
	OPERATOR SAFETY: Use caution to avoid risk of injury.
	CAUTION: A process that must be carefully observed in order to reduce the risk of damage to the accessory/vehicle and to ensure a quality installation.
	TOOLS & EQUIPMENT: Used in Figures calls out the specific tools and equipment recommended for this process.
	REVISION MARK: This mark highlights a change in installation with respect to previous issue.
	SAFETY TORQUE: This mark indicates that torque is related to safety.

Parts Description of Tuner Assy (86180-0W030)

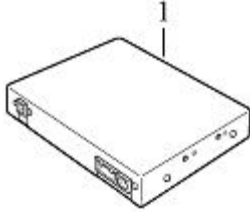

Item #	Parts Name	Parts No.	Qty
1	Tuner	86180-0W030	1

Parts Description of Mounting Kit (PT546-52080)

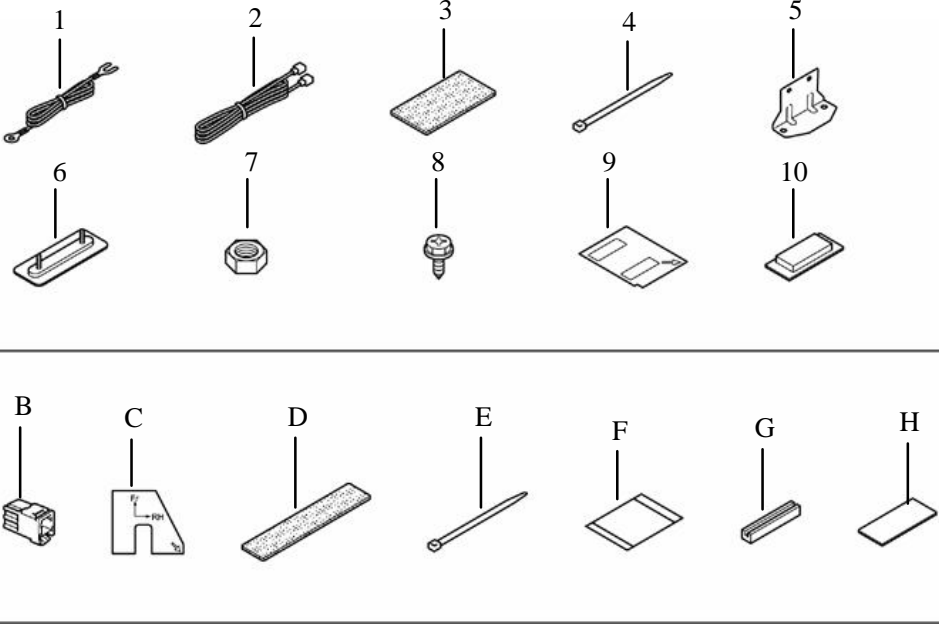

11 —

Item #	Parts Name	Qty	
1	Ground Cable	1	
2	Wire, To Radio Installation	1	
3	Cushion Tape (50 x 100 mm) (0 used for xB)	2	
4	Lock Tie A (AVC-LAN)	15	
5	Tuner Bracket	2	
6	Base Bracket	2	
7	Nut (M6)	4	
8	Screw (M5 x L8)	4	
9	Template A (to locate bracket)	1	
10	Cushion A (Butyl)	4	
11	A	Antenna	1
	B	Connector Housing	1
	C	Template B	1
	D	Cushion Tape (20 x 100 mm)	1
	E	Lock Tie B (antenna cable)	8
	F	Sheet Tape (to fix antenna) (8 used for xB)	10
	G	Cord Rail (30 mm)	1
	H	Protective Sheet (20 x 40 mm)	3

Care must be taken when installing this accessory to ensure damage does not occur to the vehicle. The installation of this accessory should follow approved guidelines to ensure a quality installation.

These guidelines can be found in the "Accessory Installation Practices" document.

This document covers such items as:-

- Vehicle Protection (use of covers and blankets, cleaning chemicals, etc.).
- Safety (eye protection, rechecking torque procedure, etc.).
- Vehicle Disassembly/Reassembly (panel removal, part storage, etc.).
- Electrical Component Disassembly/Reassembly (battery disconnection, connector removal, etc.).

Please see your Toyota dealer for a copy of this document.

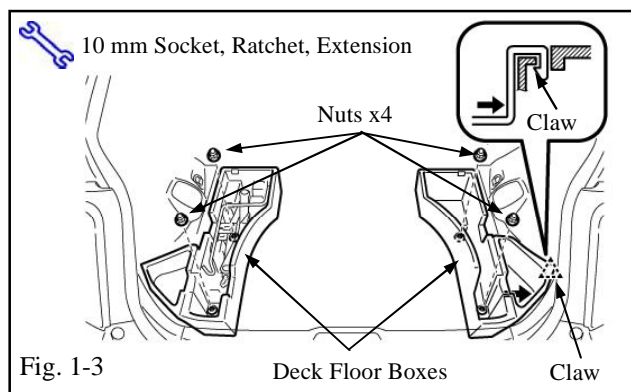
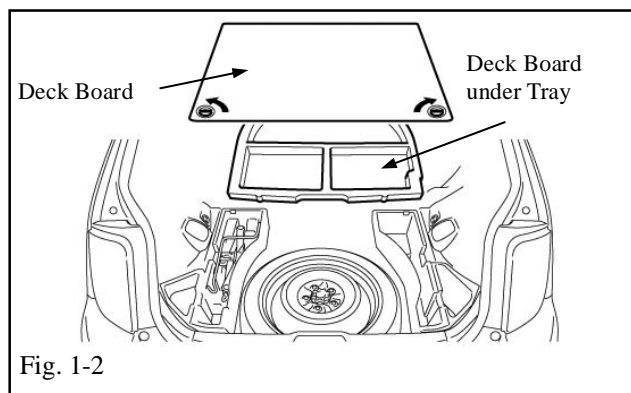
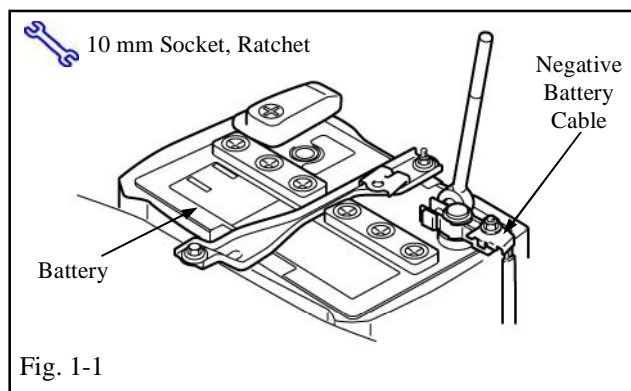

NOTES

STOP Removed Parts:
Place all removed parts on a protected surface.

STOP Connectors:
When disconnecting connectors, do not pull on the wires; pull on the connectors.

STOP Lock Ties:
When using lock ties to secure harness, clip the lock ties after securing them.

STOP Machine Screws:
Start all machine screws by hand.

Back door lock cannot be released without reconnecting negative battery cable.

1. Vehicle Disassembly

(a) Remove the negative battery cable.
(Fig. 1-1)

STOP (1) Protect the fender before starting.

+ (2) Do not touch the positive terminal with any tool when removing cable.

(b) Remove the deck board and under tray from the cargo area. (Fig. 1-2)

(c) Remove the four (4) nuts and then remove both deck floor boxes. (Fig. 1-3)

STOP **NOTE:** A claw is attached to the right deck floor box. When removing the box, detach the claw by pushing the lower part of the box outward as shown in the illustration.

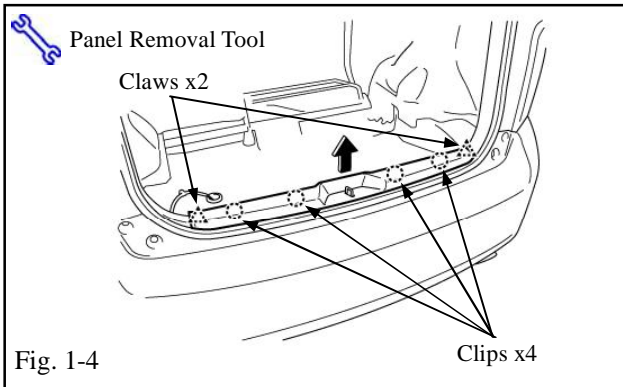

- (d) Disengage two (2) claws and four (4) clips, then pull upward and remove the deck trim cover. (Fig. 1-4)

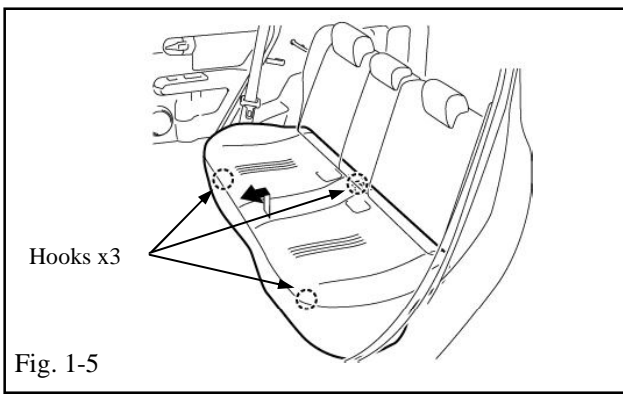

- (e) Disassemble the rear seat as follows:
 - (1) Disengage the three (3) hooks and remove the rear seat cushion. (Fig. 1-5)

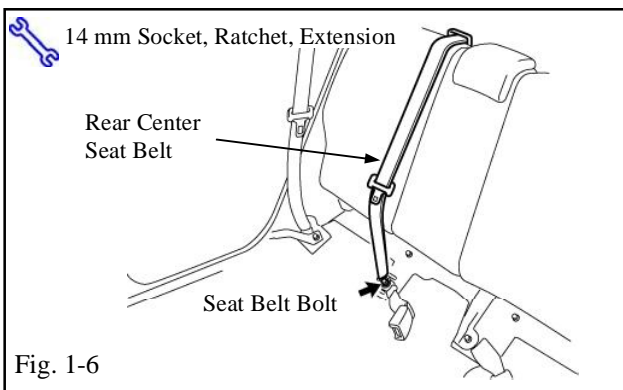

- (2) Remove the rear center seat belt installation bolt. (Fig. 1-6)

STOP NOTE: Be careful not to scratch or damage the vehicle body with the seat belt components. Apply masking tapes around the metallic parts of the seat belt.

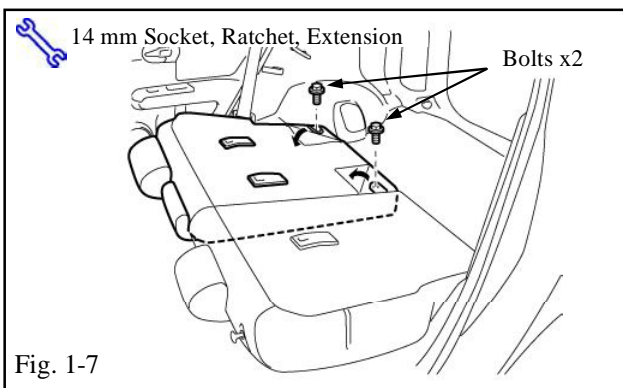

- (3) Fold down the seatback, and then fold back the cover to locate the two (2) bolts.
 - (4) Unbolt and remove the right rear seatback. (Fig. 1-7)

STOP NOTE: Be careful not to damage the seat, the door, and other vehicle parts when removing the seat from the vehicle.

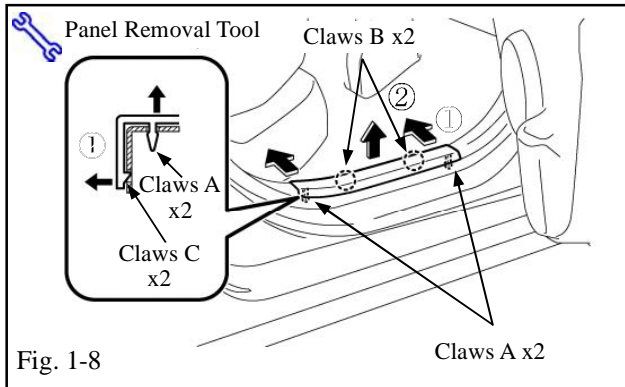

- (f) Disengage the six (6) claws and remove the rear passenger side door scuff plates. (Fig. 1-8)

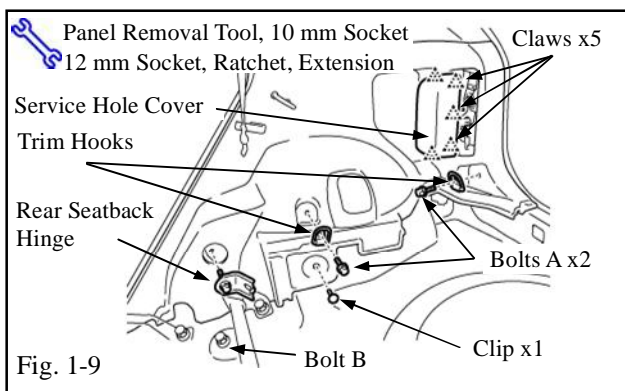

- (g) Remove the passenger side deck trim side panel as follows (Fig. 1-9):

- (1) Remove the service hole cover.
- (2) Remove two (2) bolts A to detach the luggage compartment trim hooks.
- (3) Remove the clip.
- (4) Remove the bolt B and rear seatback hinge.

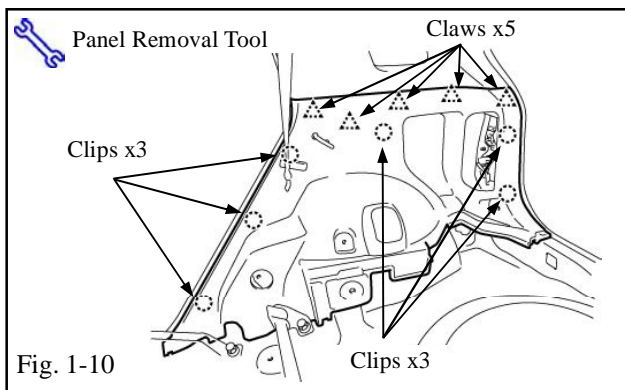

- (5) Disengage the clips and claws, then remove the deck trim side panel. (Fig. 1-10)

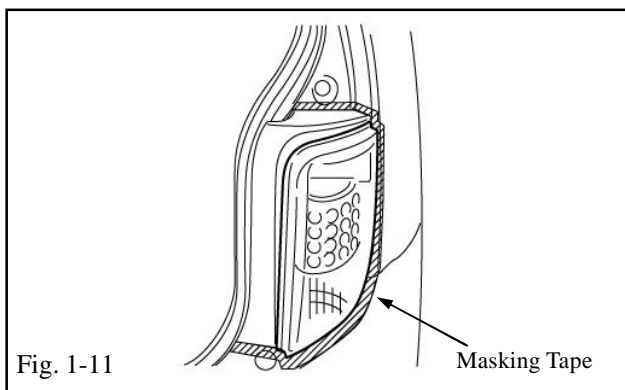

- (h) In order to prevent scratches, apply masking tape around the right side rear combination light before removing it. (Fig. 1-11)

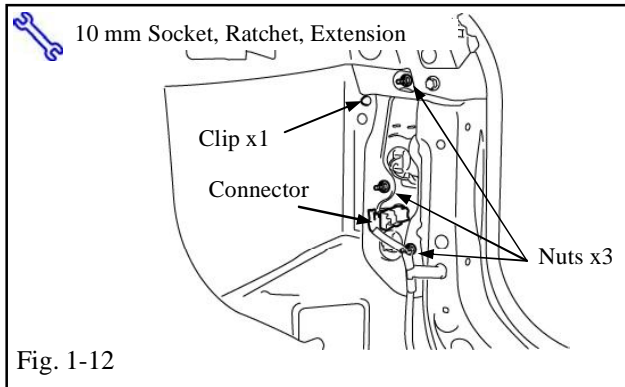

- (i) Disconnect the connector and remove the three (3) nuts, then detach the right side rear combination light. (Fig. 1-12).

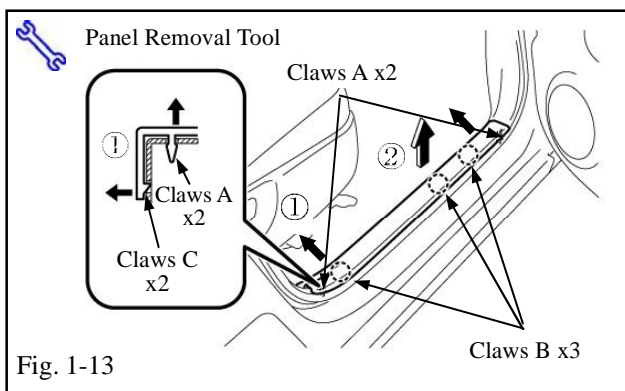

- (j) Disengage the seven (7) claws and remove the front passenger side door scuff plates. (Fig. 1-13)

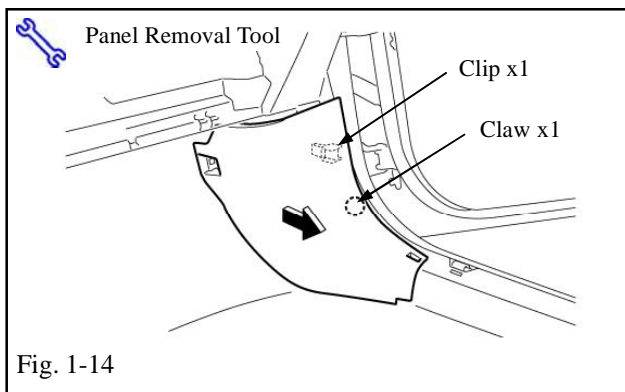

- (k) Disengage the clip and the claw, then remove the passenger side cowl side trim. (Fig. 1-14)

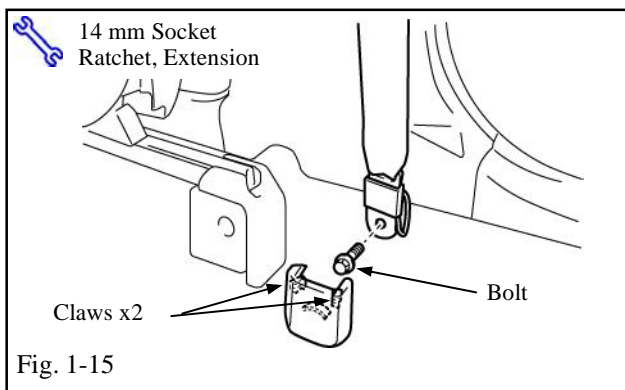

- (l) Disassemble the passenger front seat belt as follows (Fig. 1-15):
 - (1) Remove the passenger front seat belt anchor cover.
 - (2) Unbolt and detach the passenger front seat belt anchor plate.

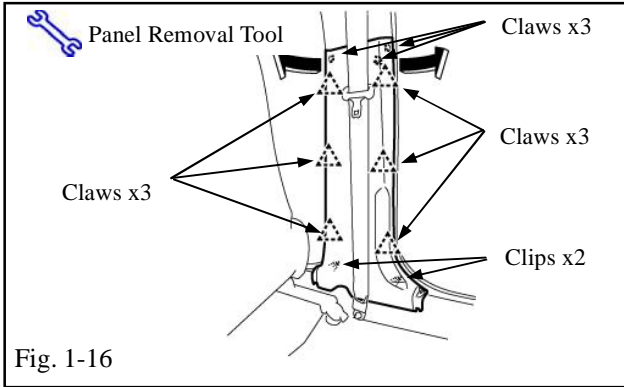

- (m) Disengage the nine (9) claws and two (2) clips, then remove the passenger side lower center pillar garnish. (Fig. 1-16)

2. Remove the Radio/Player Head Unit

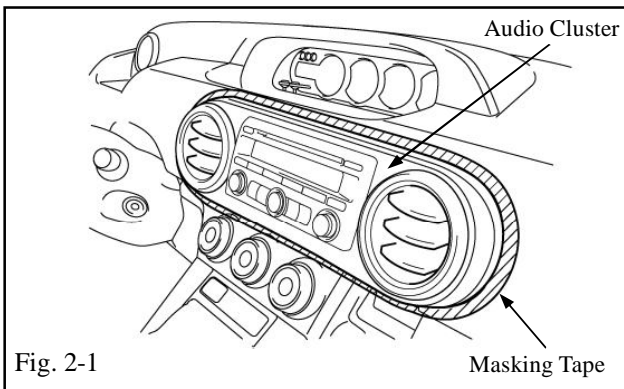

- (a) In order to prevent scratches, apply masking tape around the audio cluster (shaded areas in the figure) before removing the audio cluster. (Fig. 2-1)

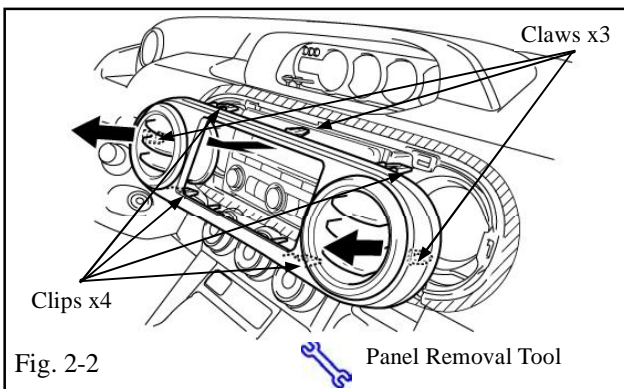

- (b) Disengage the four (4) clips and the three (3) claws, then remove the audio cluster. (Fig. 2-2)

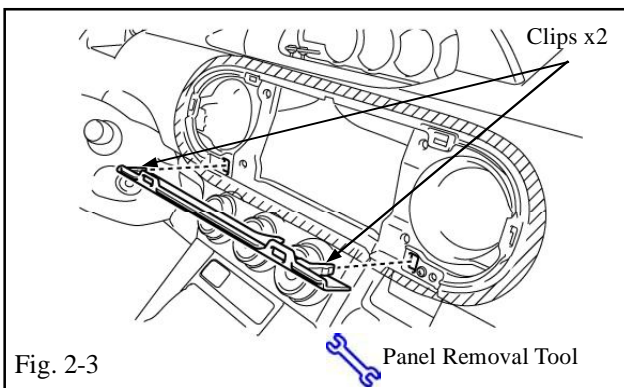

- (c) Disengage the two (2) clips and remove the audio cluster under plate. (Fig. 2-3)

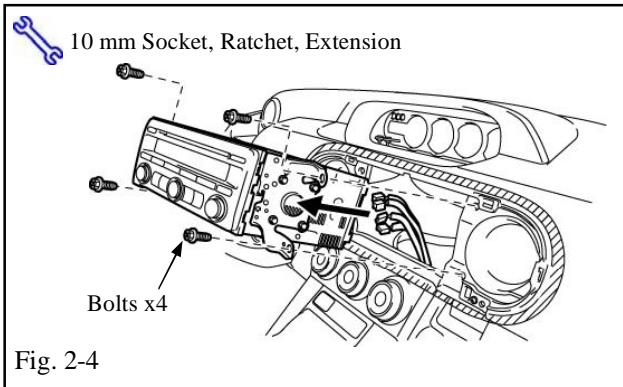

- (d) Remove the four (4) bolts and remove the head unit (Fig. 2-4).
- (e) Disconnect the connectors.

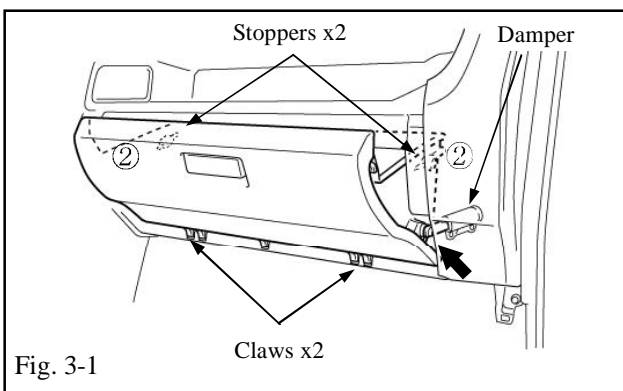

3. Remove the Glove Compartment Door

- (a) Disconnect the damper from the glove compartment door.
- (b) Squeeze both ends of the box together to fully extend the box, and then remove the stoppers. (Fig.-3-1)
- (c) Disengage the two (2) claws, and then remove the glove compartment door.

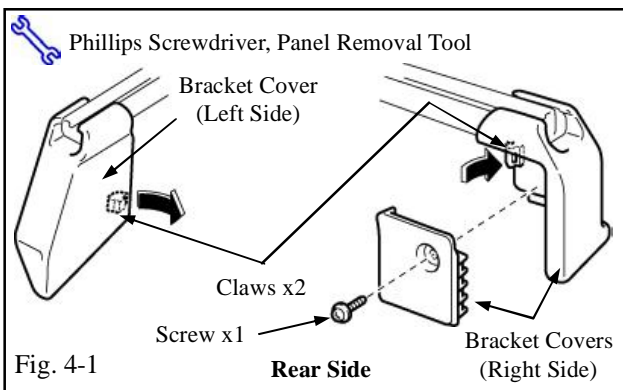

4. Remove Front Passenger Seat

-  (a) Protect the rear seat area, the floor, and the center console area.
- (b) Remove the screw and then disengage the claws and remove the seat track bracket covers. (Fig. 4-1)

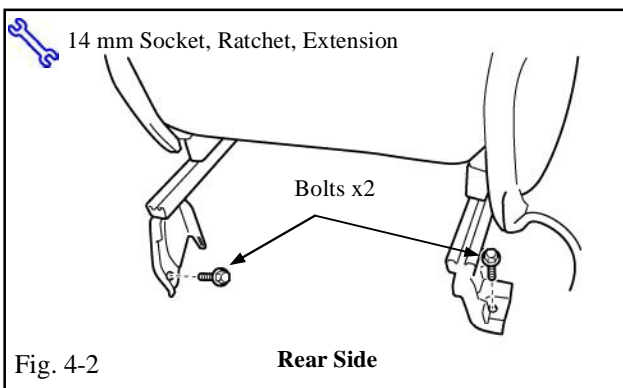

- (c) Remove the two (2) seat rear bolts. (Fig. 4-2)
- (d) Slide the seat backward.

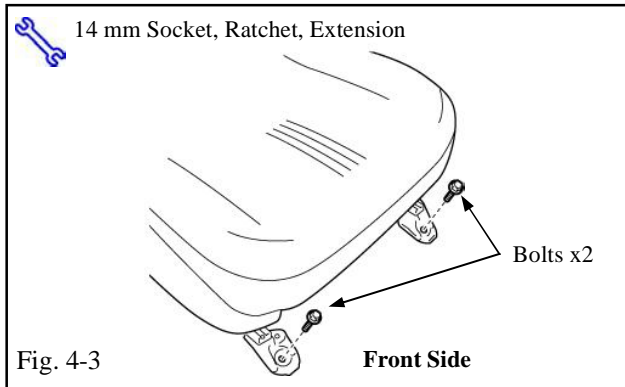

- (e) Remove the two (2) seat front bolts. (Fig. 4-3)
- (f) Disconnect the wire harness clamp and connectors.
- (g) Tilt the seat rearwards, exposing the floor under the front passenger seat, and lay the seat in the rear seat area.
- (h) Secure the seat to keep it from falling (optional).

5. Route the Satellite Tuner Cable

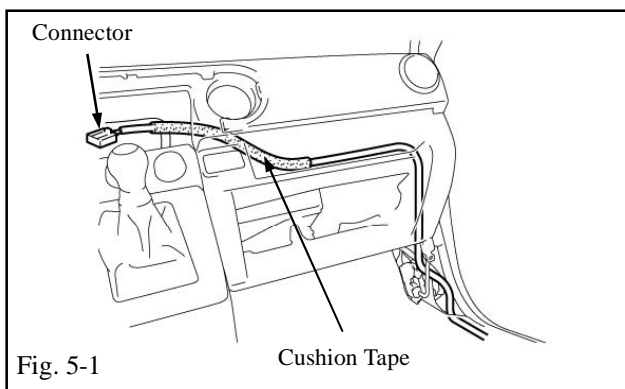

- (a) Route the tuner cable from the cowl side trim to the head unit as shown. (Fig. 5-1)

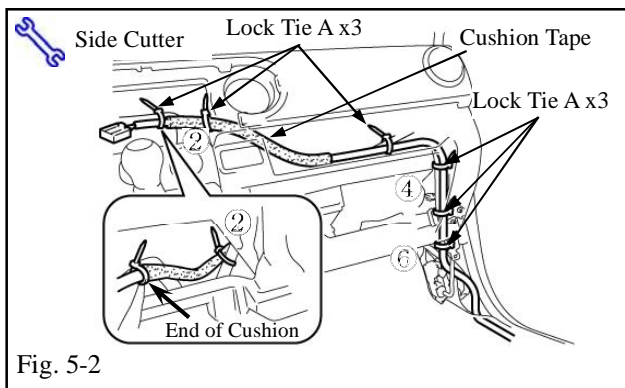

- (b) Secure the tuner cable with the vehicle wire harness. Install six (6) lock ties A as shown. (Fig. 5-2)

STOP NOTE: Match the position of the connector and the length of the cable to other connectors connected with the head unit.

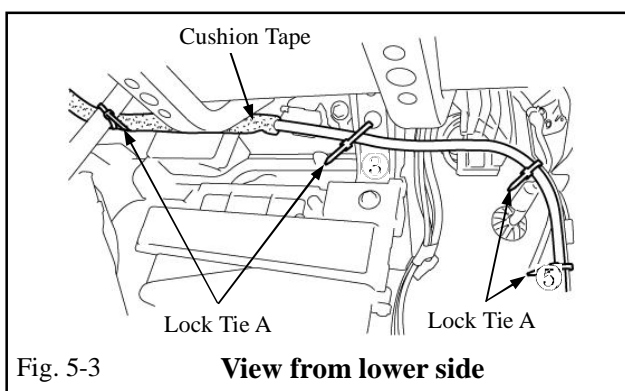

- (c) Check that the lock ties are at the correct positions. (Fig. 5-3)
- (d) Use a side cutter to cut off the excess lock tie length.

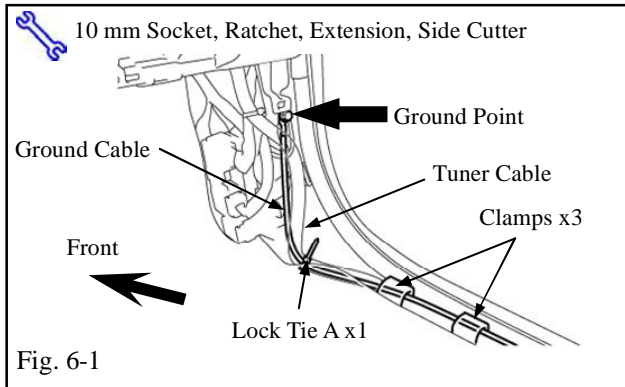

6. Route the Tuner Ground Cable

- (a) Install the end of the tuner ground cable onto the bolt located on the cowl side. (Fig. 6-1)
- (b) Secure the tuner ground cable and tuner cable using the vehicle wire harness clamps.
- (c) Secure the tuner ground cable and tuner cable to the vehicle wire harness using a lock tie A as shown. (Fig. 6-1)
- (d) Use a side cutter to cut off the excess lock tie length.

7. Install the Antenna

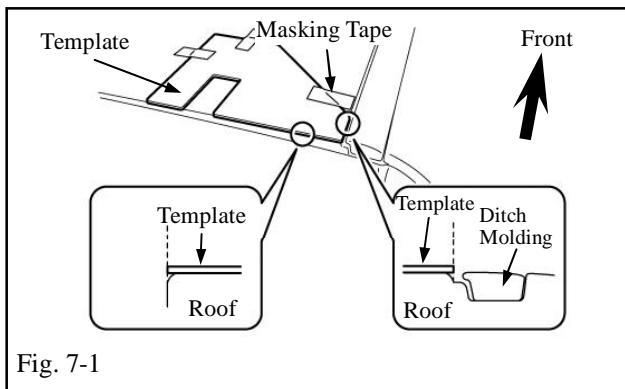

- (a) Clean the template (template B) mounting area with 3M™ Prep Solvent 70 and cleaning method. (Fig. 7-1)
- (b) When cleaning with 3M™ Prep Solvent 70 and cleaning method,



- (1) Always use a clean (lint free scratch resistant) soft cloth (or wipe), and clean a small area at a time (~ 3 ft. x 3 ft. max.).

- (2) Shake well.



- (3) Apply 3M™ Prep Solvent 70 to cloth or wipe. Do not spray cleaning solution directly on any vehicle surfaces.

- (4) Clean surface thoroughly and wipe dry immediately with a new clean cloth. Do not allow cleaner to air dry.

- (c) Position antenna template on the near right corner of the roof as shown. Secure the template with masking tape. (Fig. 7-1)

- (d) Remove the release paper from the back of antenna, and then affix the antenna onto the roof. (Fig. 7-2)

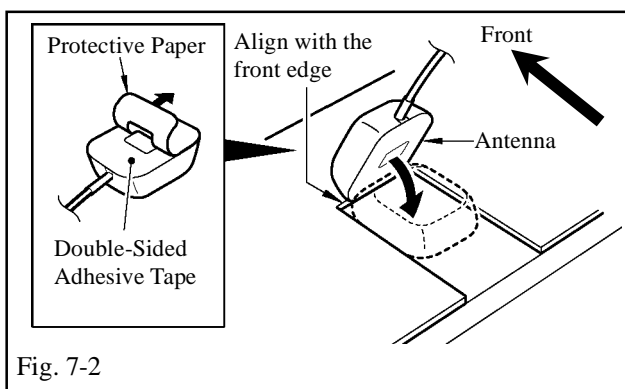

- (1) Align the front edge of the antenna with the template as shown and install it carefully.



- (2) Once attached, the antenna cannot be easily removed.

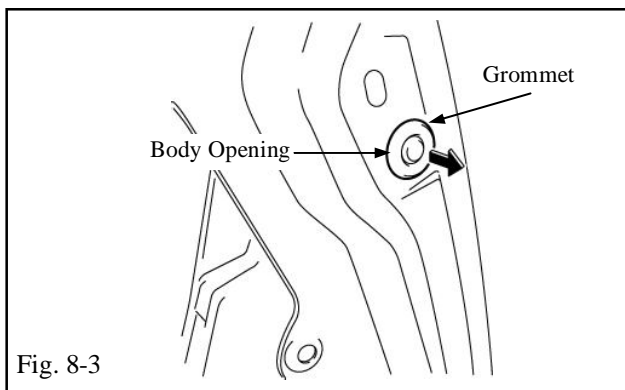
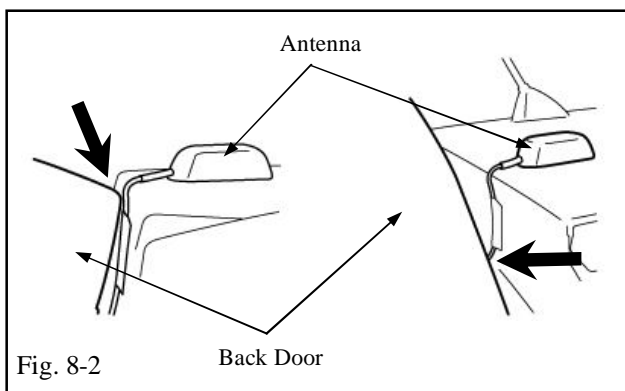
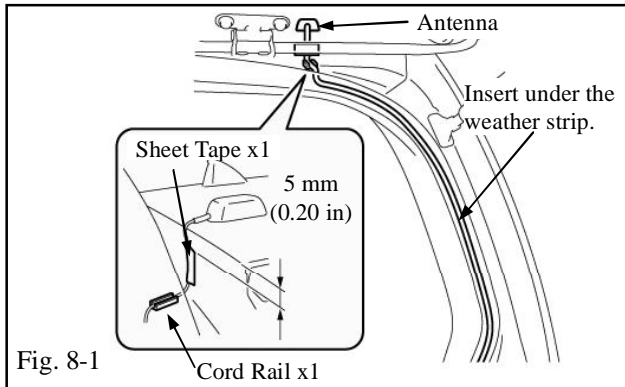

8. Route Antenna Cable through Body Opening

- (a) The roof and the roof/hatch area where the sheet tape and cord rail attach must be cleaned with 3M™ Prep Solvent 70 using the method defined in Step 7(b). (Fig. 8-1)
- (b) First, pass the grommet part through the space between the back door and the body.
- (c) Locate with sheet tape and a cord rail so the door does not contact or pinch the antenna cable. (details in Fig. 8-2)
- (d) Route the antenna cable around the body opening, and insert the cable under the weather strip.
- (e) Remove and discard the vehicle grommet covering the body opening. (Fig. 8-3)
 - (1) From the inside, push outward and remove the grommet plug of the right rear combination light installation area, then route the antenna cable through the body hole.
- (f) The body opening where the antenna grommet attaches must be cleaned with 3M™ Prep Solvent 70 and cleaning method.
- (g) After cleaning, apply 3M™ Ultra-Pro Body Sealant to the backside of the grommet.

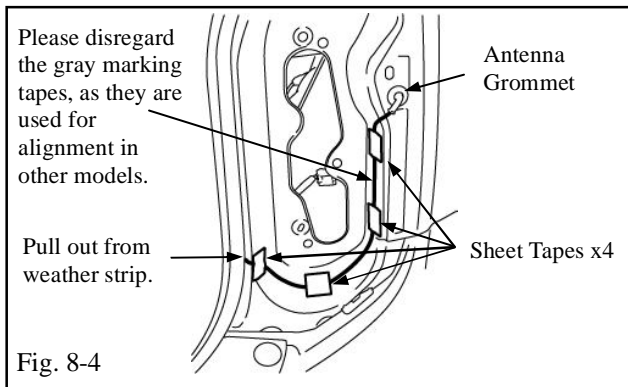

- (h) Run the antenna cable and insert the antenna grommet (attached to cable) into the body opening. (Fig. 8-4)
- (i) Secure the antenna cable around the area where the rear combination light is installed as shown using four (4) sheet tape pieces. (Fig. 8-4)
 - (1) Make sure the tape does not contact the rubber with the backside of the rear combination lamp.
- (j) Wrap the cushion tape around the antenna cable as shown in the illustration. (Fig. 8-5)

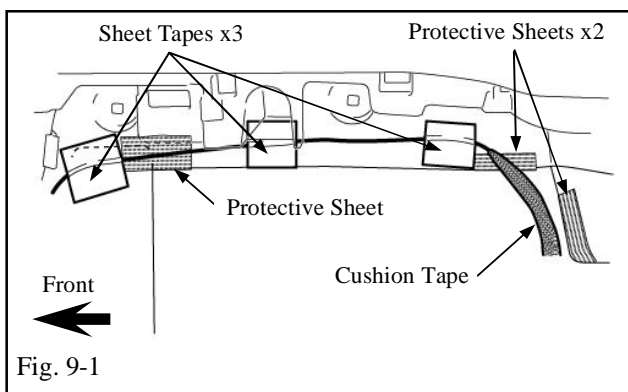
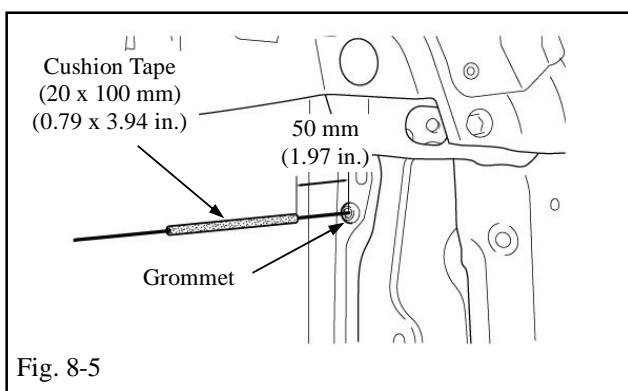

9. Secure the Antenna Cable

- (a) Secure the antenna cable to the rear right side inner panel using the three (3) sheet tapes and three (3) protective sheets as shown. (Fig. 9-1)

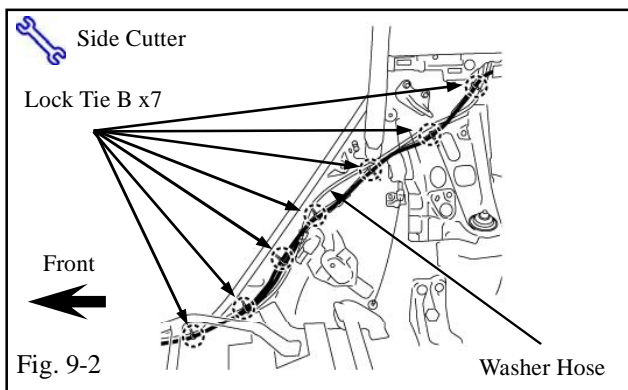

- (b) Secure the antenna cable to the vehicle wire harness using the seven (7) lock ties (type B). (Fig. 9-2)



NOTE: Do NOT secure the antenna cable to the washer hose.

- (c) Use a side cutter to cut off the excess lock tie length.

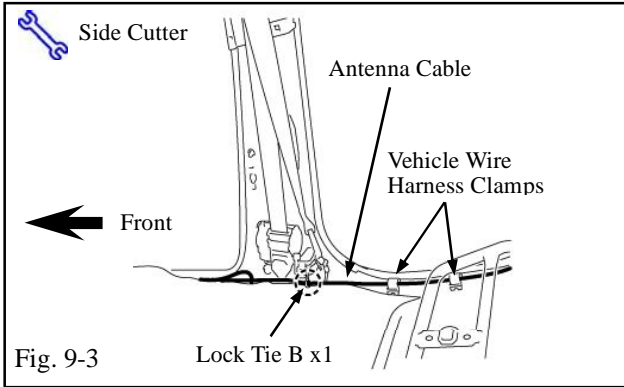

- (d) Secure the antenna cable to the vehicle wire harness using the one (1) lock tie B and vehicle wire harness clamps. (Fig. 9-3)



NOTE: Do NOT secure the antenna cable to the washer hose.

- (e) Use a side cutter to cut off the excess lock tie length.

10. Attach a Housing to the Antenna Cable Terminal

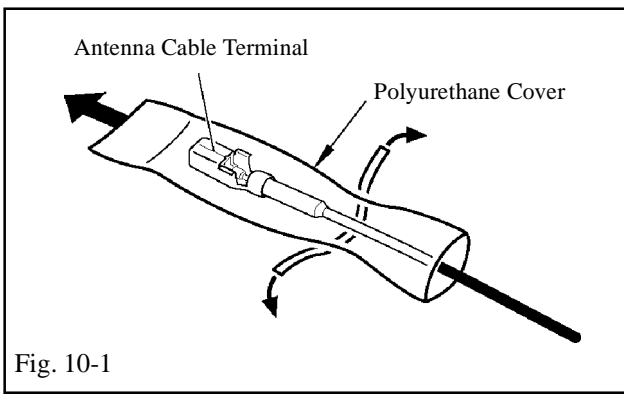

- (a) Remove the polyurethane cover from the terminal. (Fig. 10-1)

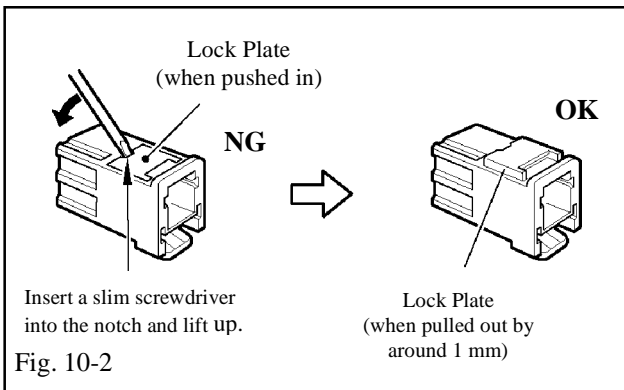

- (b) If the lock plate of the housing is pushed in, pull it out. (Fig. 10-2)

NOTE : This step is not required if the lock plate is already pulled out.

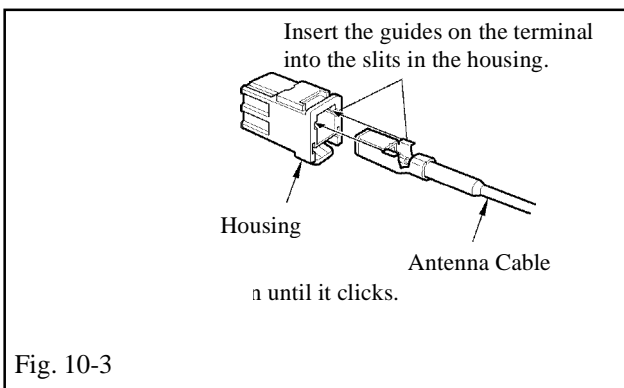

- (c) Push the terminal into the housing. (Fig. 10-3)

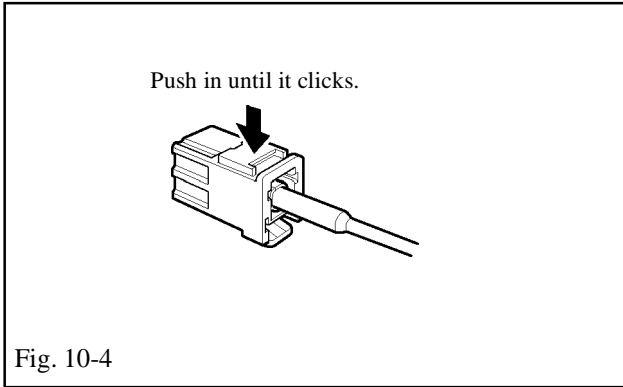

(d) Push the lock plate in (Fig. 10-4).

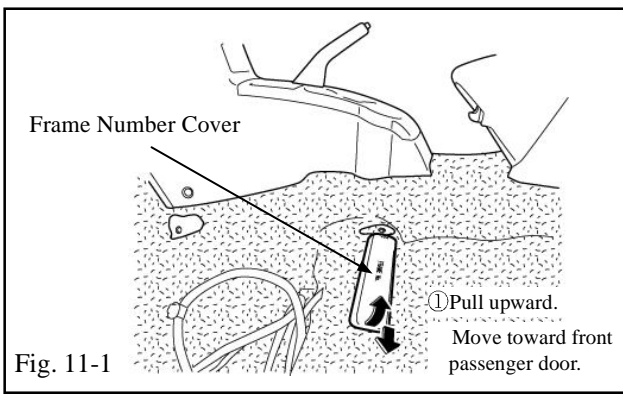

11. Install the Satellite Tuner

(a) Remove the frame number cover.
(Fig. 11-1)

(b) Peel back the carpet and felt.

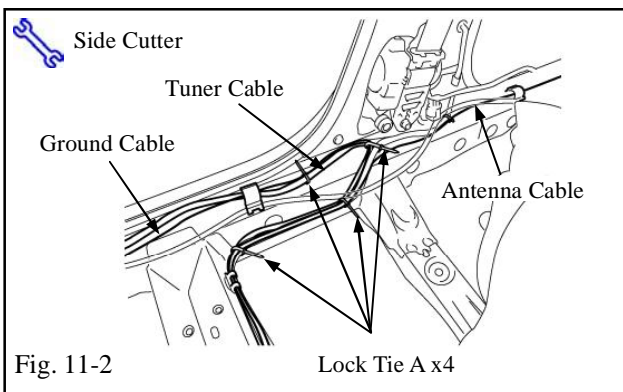

(c) At the center pillar area, route the cables and secure them to the vehicle wire harness using the lock ties A as shown. (Fig. 11-2)

(d) Use a side cutter to cut off the excess lock tie length.

(e) Clean the bracket mounting surface with 3M™ Prep Solvent 70 and cleaning method.

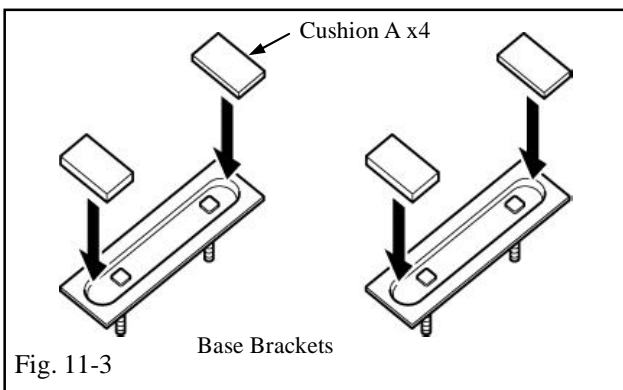

(f) Install four (4) cushion A (butyl) onto the bottom of the base brackets. (Fig. 11-3)

(g) Clean the bracket mounting surface of the vehicle floor pan with 3M™ Prep Solvent 70.

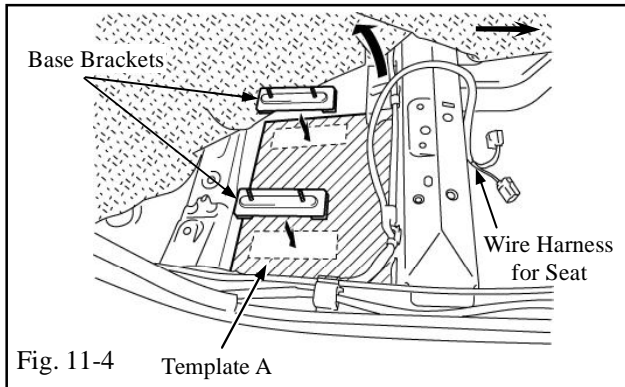

- (h) Position template A under the passenger's seat as shown. (Fig. 11-4)
- (i) Remove the release paper from the four (4) cushion tape A (butyl), and then secure the base brackets over template A as shown.
- (j) Remove template A.

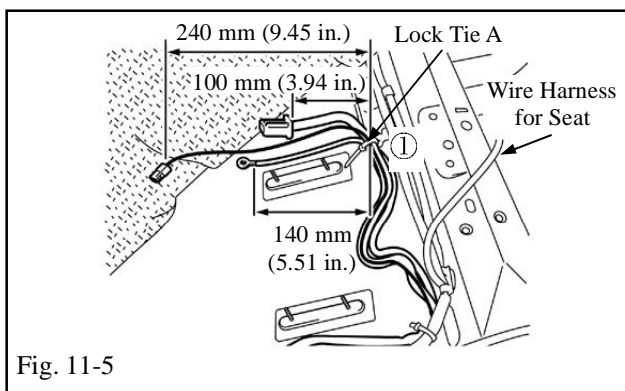

- (k) Route the tuner cable, tuner ground cable and antenna cable together and secure the excess of the cables using lock ties A.



NOTE: Never secure them with the wire harness for the seat.

- (1) Route the cables under the carpet as shown. Set the length of the cables over the carpet required; 140 mm (5.51 in.) of the tuner ground cable, 100 mm (3.94 in.) of the tuner cable and 240 mm (9.45 in.) of the antenna cable, and secure the cables with one (1) lock tie A (). (Fig. 11-5)



- (2) Locate the secured cables to the floor as shown. (Fig. 11-6)

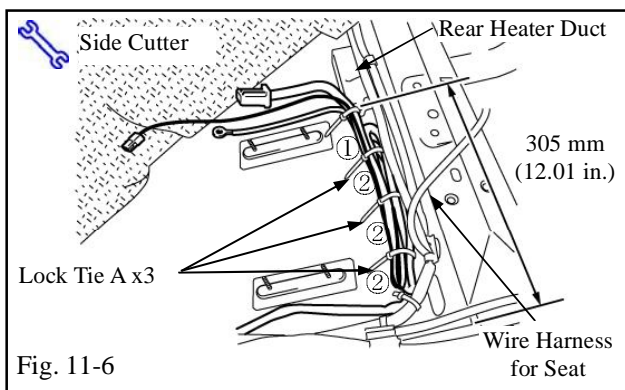

- (3) Verify the cables do not block the rear heater duct.
- (4) Secure the excess of the cables to the vehicle wire harness using three (3) lock ties A (②). (Fig. 11-6)
- (5) Use a side cutter to cut off the excess lock tie length.

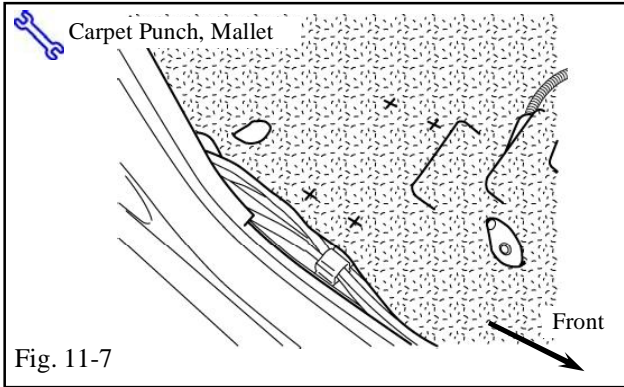

- (l) Reinstall the carpet and verify the base bracket bolt positions. Transfer each bolt location onto the carpet using carpet punch and mallet to cut four (4) holes in carpet. (Fig. 11-7)

(m) Pass the base bracket bolts through the carpet.

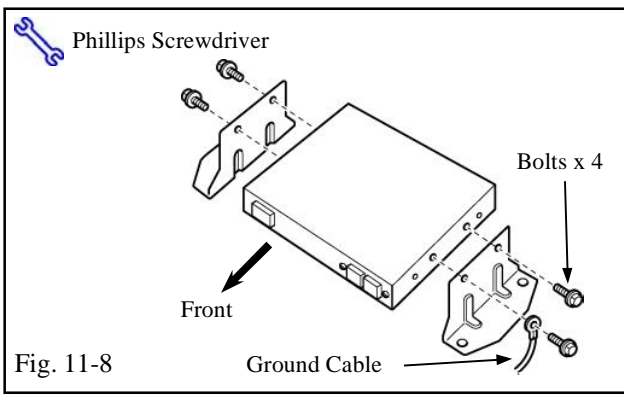

(n) Install the satellite tuner brackets and ground cable onto the tuner. (Fig. 11-8)

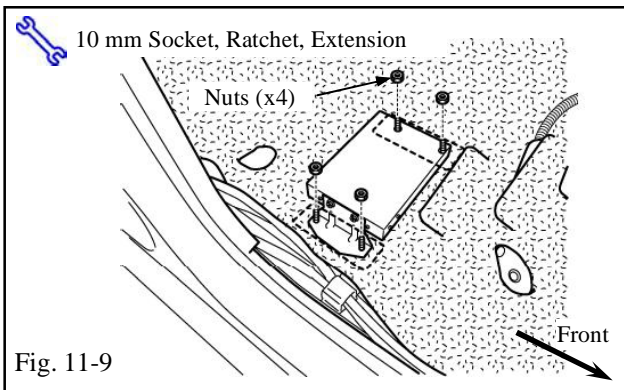

(o) Secure the satellite tuner onto the base brackets so the connectors face toward the front of the vehicle. (Fig. 11-9)

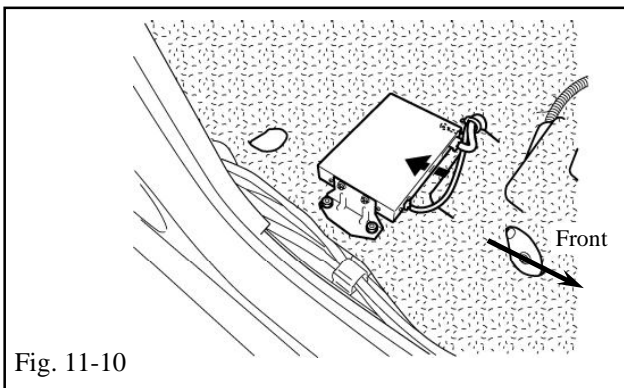

(p) Plug the tuner cable and antenna cable into the tuner. (Fig. 11-10)

(1) Connect the antenna cable connector to the tuner.

(2) Connect the tuner cable (wire, to radio installation) to the tuner.

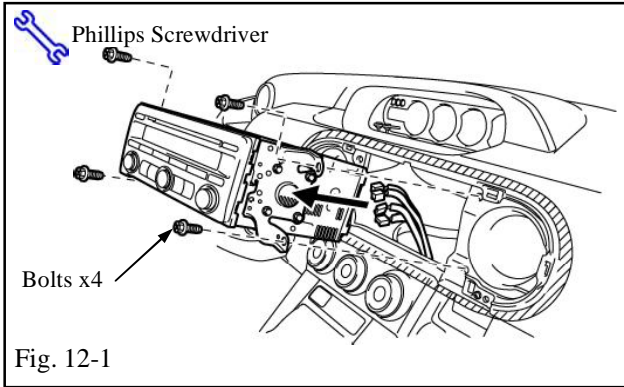

12. Reinstall the Radio/Player Head Unit

- (a) Connect the satellite tuner cable and the connectors removed in Step 2(b) into the rear of the head unit. (Fig. 12-1)
- (b) Insert head unit into opening and re-install the bolts. (Fig. 12-1)

13. In Process Functional Test

- (a) Temporarily reconnect battery negative cable.
- (b) Turn ignition key to “ACC” position.
- (c) Press the power button on the receiver/player head unit. Verify the backlighting illuminates.
- (d) Press and release the “SAT” button on the head unit.
 - (1) Verify that a satellite channel is received, or a “NO SIGNAL” message appears on the display.

NOTE: If “ANTENNA” appears (flashing) on the display – then the antenna cable is disconnected from the satellite tuner.

NOTE: If the head unit will not tune or go into satellite mode – then the tuner cable is disconnected from the satellite tuner.

- (e) Disconnect battery negative cable.

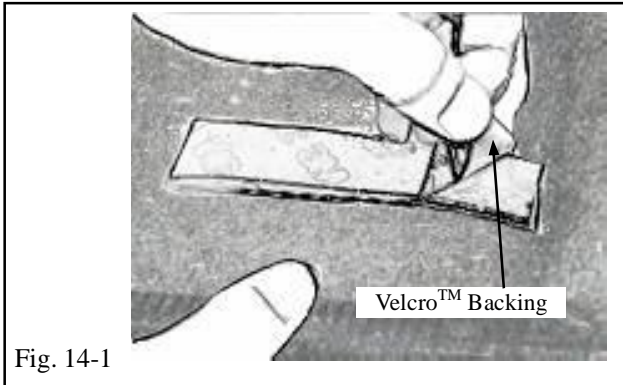

Fig. 14-1

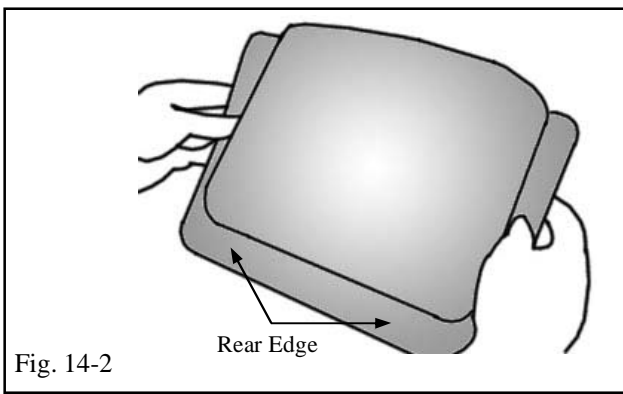

Fig. 14-2

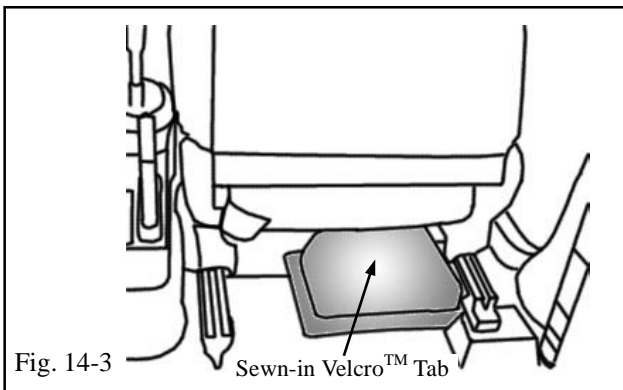

Fig. 14-3

14. Installing Receiver Cover

- (a) Remove the satellite receiver cover (P/N PT218-52071) from the poly bag.
- (b) Shape the cover so that it forms an open box shape with the Velcro™ facing down.

NOTE: Shipping and storage may have caused the shape to distort.

- (c) Peel the backing off the sewn-in Velcro™ strip inside the cover. (Fig.-14-1).
 - (1) Do not separate the Velcro™.
- (d) Clean the top of satellite receiver box with 3M™ Prep Solvent 70 using the method defined in Step 7(b).
- (e) Align the rear edge of the cover with the rear edge of the satellite receiver. (Fig. 14-2).
- (f) Center cover to ensure satellite receiver mounting bolts are covered. Press Velcro™ to the floor carpet around the perimeter.
- (g) Press the sewn-in Velcro™ tab on the top underside of the cover firmly to the satellite receiver. (Fig. 14-3).

15. Complete the Reassembly of Vehicle

- (a) Reinstall rear combination light.
- (b) Reconnect any disconnected connectors.
- (c) Re-install the front seat
 - (1) Reinstall the four (4) bolts loosely, then tighten them in the following order:
 - Rear inner bolt
 - Rear outer bolt
 - Front inner bolt
 - Front outer bolt
 - (2) Tighten bolts to 37 N•m (27 lbf•ft)



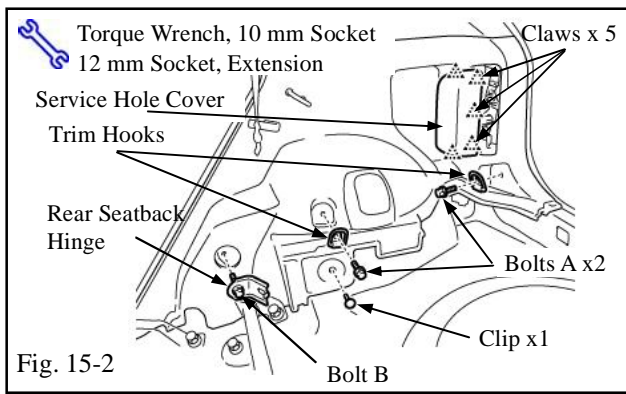
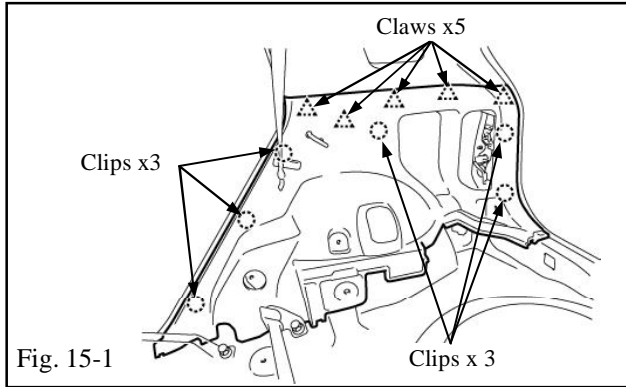

(d) Re-install the passenger side deck trim side panel as follows:

- (1) Install the deck trim side panel and engage the clips and claws. (Fig. 15-1)

(e) Install the rear seatback hinge and bolt B. (Fig. 15-2)



- (1) Tighten bolt B to 18 N•m (13 lbf•ft)

(f) Install the two (2) luggage compartment trim hooks with the bolts A.

(g) Install the service hole cover.

(h) Re-assemble the passenger front seat belt.

- (1) Bolt and attach the passenger front seat belt anchor plate.



- (i) Tighten the bolt to 42 N•m (31 lbf•ft)

(2) Attach the passenger front seat belt anchor cover.

(i) Re-assemble the rear seat.



- (1) Install the rear center seat belt installation bolt and tighten it to 42 N•m (31 lbf•ft).

(2) Install the rear seat cushion, taking care that the retaining hooks are securely engaged.

(3) Bolt and attach the right rear seatback.



- (4) Tighten bolts to 42 N•m (31 lbf•ft)

(5) Fold up the seatback, and then fold down the cover over the bolts.



(j) Verify the panels fit together properly with no uneven gaps between them.

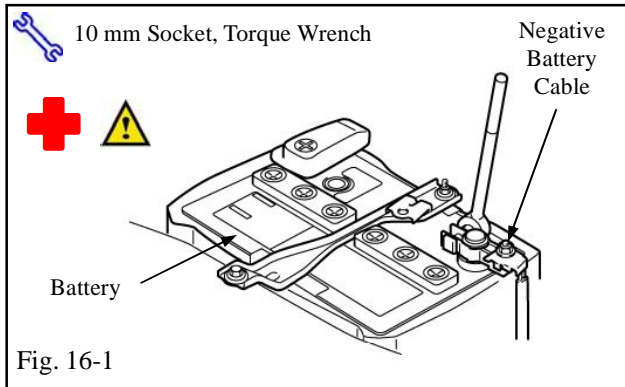

16. Reconnect Battery Cable

(a) Reconnect the vehicle's negative battery cable. (Fig. 16-1)

(1) Position the negative terminal to the battery as shown (original factory position).



(2) Tighten the nut to 4.1 N•m (36 lbf•in).



(3) Do not touch the positive terminal with any tool when installing the cable.

(b) Clean up and remove any trash.



(c) Place the owner "XM Satellite Radio" brochure in the glove box.

Checklist - these points **MUST** be checked to ensure a quality installation.

Check:	Look For:
<p><u>Accessory Function Checks</u></p> <p><input type="checkbox"/> Satellite Radio Tuner</p> <p><input type="checkbox"/> Receiver/player Assembly</p>	<p>*Verify the proper operation of the Satellite Radio Tuner.</p> <p>*Verify the proper operation of the Receiver/player Assembly</p> <p>*(Refer to the receiver assembly and radio owner's manuals.)</p>
<p><u>Vehicle Function Checks</u></p> <p><input type="checkbox"/> Hazard switch</p> <p><input type="checkbox"/> Passenger's seat belt reminder light</p> <p><input type="checkbox"/> Removed seat</p> <p><input type="checkbox"/> Proper operation of the removed seat lock mechanism</p> <p><input type="checkbox"/> Rear combination lamp Assy</p> <p><input type="checkbox"/> SRS warning light</p> <p><input type="checkbox"/> HVAC (heating ventilation and air conditioning system)</p> <p><input type="checkbox"/> SSP function</p>	<p>Proper operation of the hazard switch.</p> <p>Proper operation of the passenger's seat belt reminder light.</p> <p>Verify the removed seat is securely fastened.</p> <p>Verify the proper operation of the removed seat lock mechanism.</p> <p>Verify proper operation of the removed rear combination lamp Assy.</p> <p>Verify the SRS warning light illuminates for approximately 6 seconds with the ignition ON, and then goes out.</p> <p>Proper operation of the air conditioning system.</p> <p>Verify the radio SSP function is set to "xB" by pressing the "SSP" button on the head unit for 5 seconds. (If not, press the volume control and set to "xB".)</p>