

**Part Number: Mounting Kit PT546-02080
Tuner Assembly 86180-0W031**

NOTE: Part number of this accessory may not be the same as the part number shown.

Tuner Assembly Kit Contents (86180-0W031)

Item #	Quantity Reqd.	Description
1	1	Tuner Assy, Stereo Component

Mounting Kit Contents (PT546-02080)

Item #	Quantity Reqd.	Description
1	1	Tuner Bracket
2	1	Antenna Cable
3	2	Hardware Bags

Hardware Bag Contents - 1 (PT546-02080)

Item #	Quantity Reqd.	Description
1	4	Screw A (M5xL8)
2	1	Nut A (M6)
3	1	Nut B (M6)
4	1	Screw B (M6xL10)

Hardware Bag Contents - 2 (PT546-02080)

Item #	Quantity Reqd.	Description
1	1	Cushion Tape (50 x 100mm)
2	5	Lock Tie A (Antenna Cable)

Additional Items Required For Installation

--

Conflicts

JBL Premium Audio

Recommended Tools

Personal & Vehicle Protection	Notes
Special Tools	Notes
Installation Tools	Notes
Ratchet	
Extensions	
Sockets	10mm
Torque Wrench	4.1N•m (36 lbf•in)
Screwdriver	Philips, #2
Panel Removal Tool	e.g. panel pry Tool #1 Toyota SST#00002-06001-01
Side Cutter	
Special Chemicals	Notes

General Applicability

--

Recommended Sequence of Application





Item #	Accessory

*Mandatory

Vehicle Service Parts (may be required for reassembly)

Item #	Quantity Reqd.	Description

Legend

	STOP: Damage to the vehicle may occur. Do not proceed until process has been complied with.
	OPERATOR SAFETY: Use caution to avoid risk of injury.
	CAUTION: A process that must be carefully observed in order to reduce the risk of damage to the accessory/vehicle and to ensure a quality installation.
	TOOLS & EQUIPMENT: Used in Figures calls out the specific tools and equipment recommended for this process.
	REVISION MARK: This mark highlights a change in installation with respect to previous issue.

Parts Description of Tuner Assembly (86180-0W031)

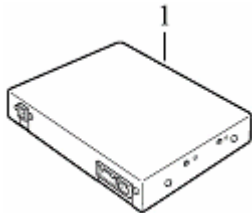

Item #	Parts Name	Parts No.	Qty
1	Tuner Assy, Stereo Component	86180-0W031	1

Parts Description of Mounting Kit (PT546-02080)

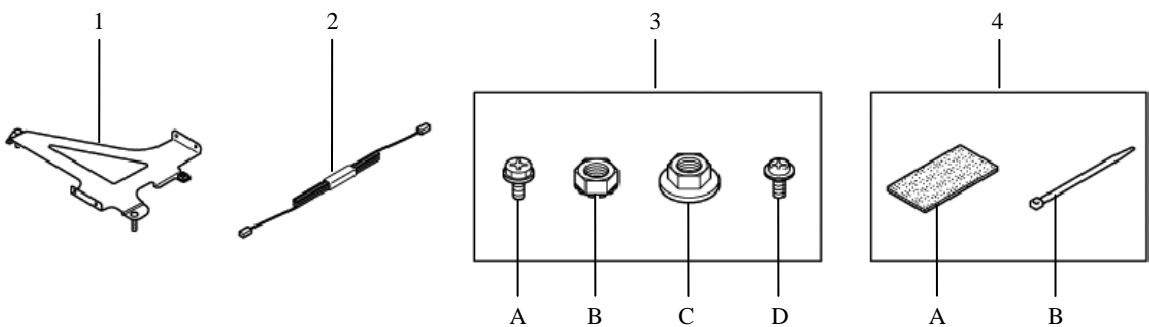

Item #	Parts Name	Qty
1	Tuner Bracket	1
2	Antenna Cable	1
3	A Screw A (M5×L8)	4
	B Nut A (M6)	1
	C Nut B (M6)	1
	D Screw B (M6×L10)	1
4	A Cushion Tape (50 × 100mm)	1
	B Lock Tie (Antenna Cable)	5

Care must be taken when installing this accessory to ensure damage does not occur to the vehicle. The installation of this accessory should follow approved guidelines to ensure a quality installation.

These guidelines can be found in the "Accessory Installation Practices" document.

This document covers such items as:-

- Vehicle Protection (use of covers and blankets, cleaning chemicals, etc.).
- Safety (eye protection, rechecking torque procedure, etc.).
- Vehicle Disassembly/Reassembly (panel removal, part storage, etc.).
- Electrical Component Disassembly/Reassembly (battery disconnection, connector removal, etc.).

Please see your Toyota dealer for a copy of this document.

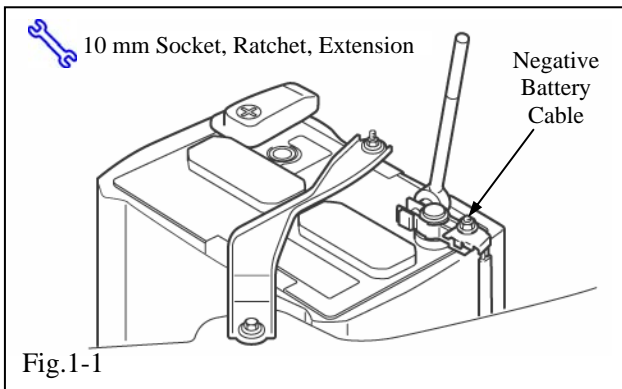

NOTES

Removed Parts: -



Place all removed parts on a protected surface.

Connectors: -



When disconnecting connectors, do not pull on the wires; pull on the connectors.

Lock Ties: -



When using lock ties to secure harness, clip the lock ties after securing them.

Machine Screws: -



Start all machine screws by hand.

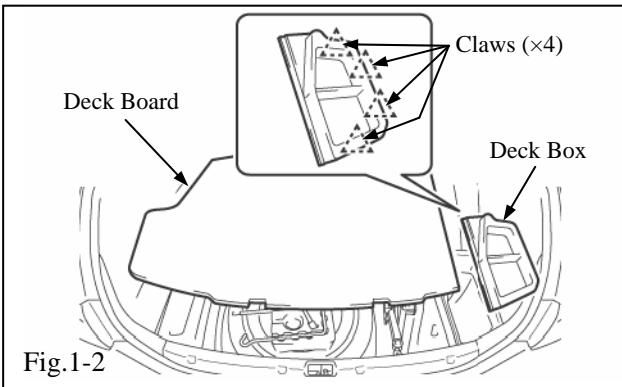

1. Disassembly of Vehicle

(a) Remove the negative battery cable. (Fig. 1-1)



(1) Protect the fender before starting.

(2) Do not touch the positive terminal with any tool when removing cable.

(b) Remove the deck board from the cargo area. (Fig. 1-2)

(c) Disengage claws and remove the deck box from the right side of the cargo area.

(d) Remove the two (2) clips and four (4) claws A from the front side of the cover. Then remove the four (4) claws B from the top surface in order to pull the deck trim cover upwards. (Fig. 1-3)

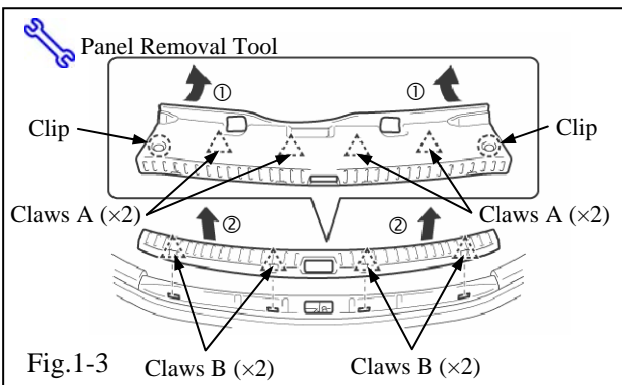

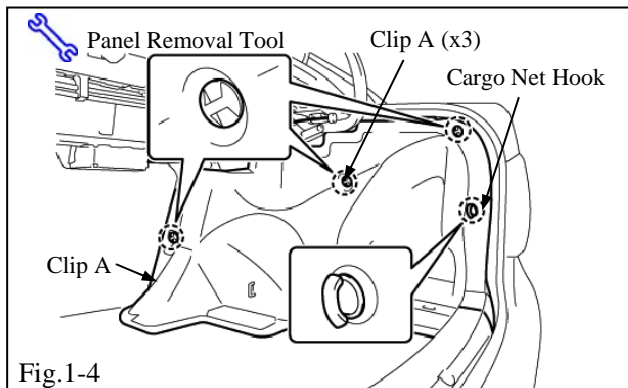

(e) Disengage the three (3) clips. (Fig. 1-4)

(f) Remove cargo net hook if applicable. If not remove clip. (Fig. 1-4)

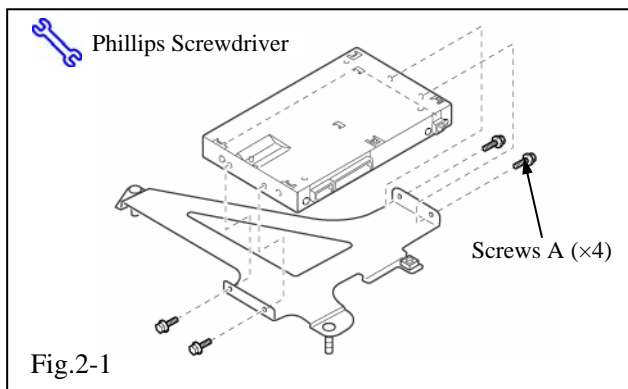

2. Install the tuner.

(a) Attach the tuner to the bracket. (Fig. 2-1)

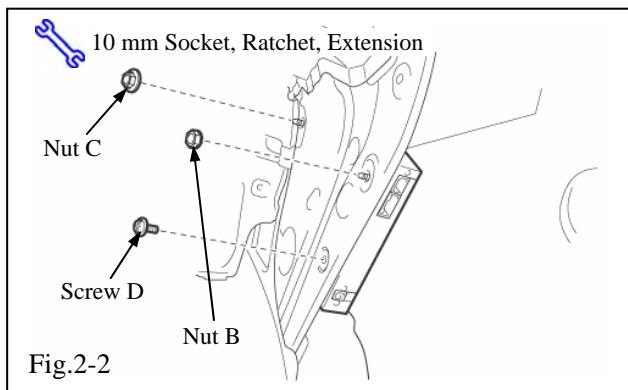

(b) Install the tuner with the bracket to the body. (Fig. 2-2)

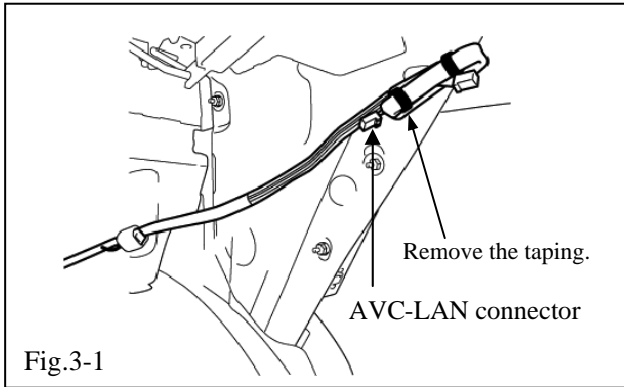

3. Install the tuner cable.

- (a) Remove the taping for the AVC-LAN on the vehicle wiring harness. (Fig. 3-1)
- (b) Attach the wiring harness to tuner.

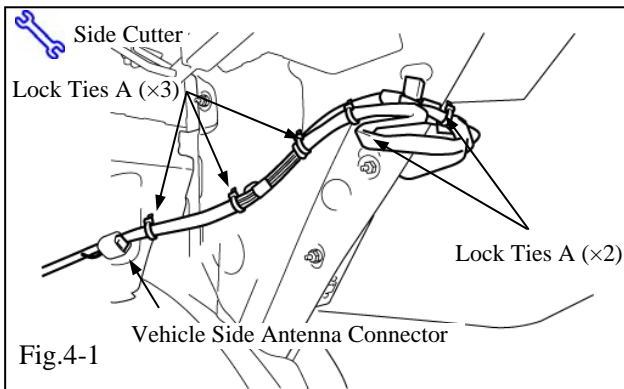

4. Install the antenna cable.

- (a) Route the antenna cable along the vehicle AVC-LAN wire harness. The short side of the antenna wire harness should be at the vehicle side connector. This will place the Bundle in the middle.
- (b) Attach the connectors to the body and tuner sides.
- (c) Fix the wire with the five (5) lock ties A. (Fig. 4-1)
- (d) Secure and bundle the antenna cable to the tuner by using the cushion tape (A). (Fig. 4-2)
- (e) Use the side cutter to cut off the excess lock ties length.

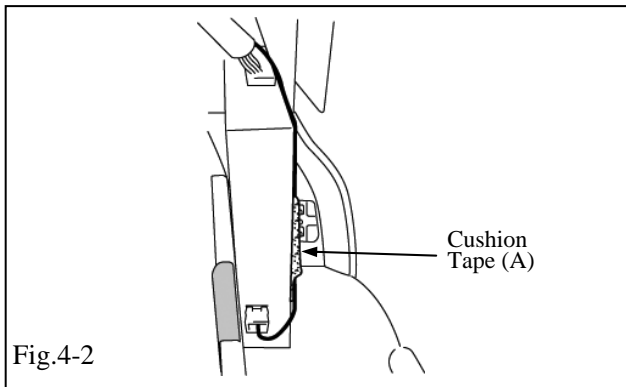

5. In Process Functional Test.

- (a) Temporarily reconnect the negative battery cable.
- (b) Install the short pin.
- (c) Turn ignition key to "ACC" position.
- (d) Press the power button on the receiver/player head unit. Verify the backlighting illuminates.
- (e) Press and release the "SAT" button on the head unit.
 - (1) Verify that a satellite channel is received, or a "NO SIGNAL" message appears on the display.

NOTE: If "ANTENNA" appears (flashing) on the display - then the antenna cable is disconnected from the satellite tuner.

NOTE: If the head unit will not tune or go into satellite mode - then the tuner cable is disconnected from the satellite tuner.

- (f) Disconnect the negative battery cable.

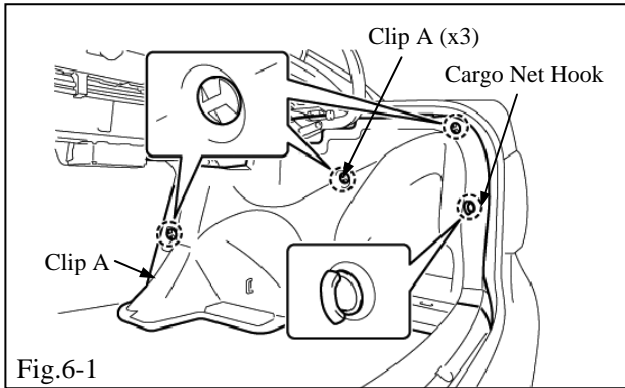

Fig.6-1

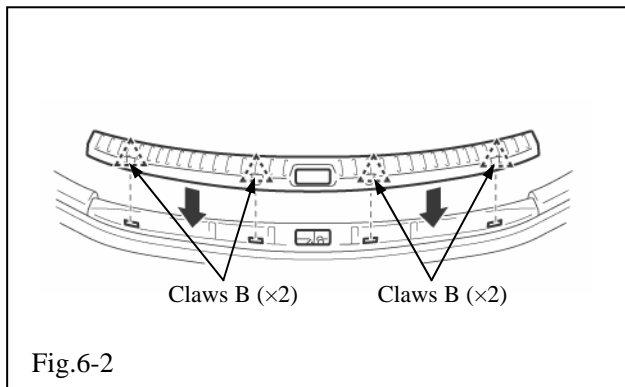

Fig.6-2

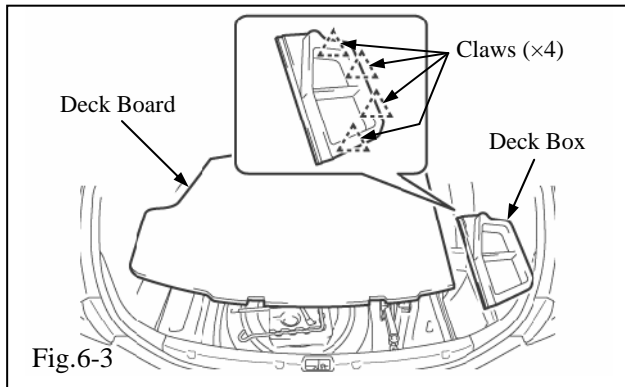

Fig.6-3

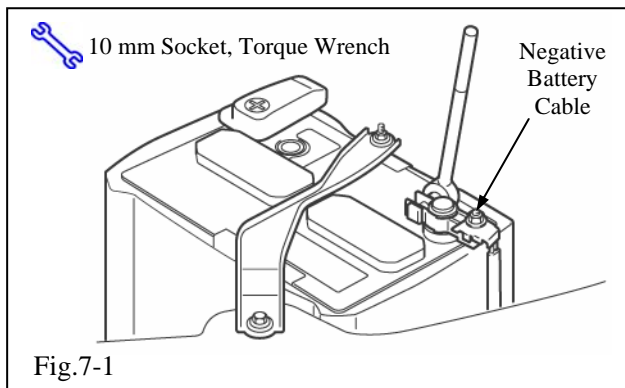

Fig.7-1

6. Complete the Reassembly of Vehicle.

- (a) Re-install the right side deck trim side panel as follows. (Fig. 6-1)
 - (1) Install the deck trim side panel and install the three (3) clips and screw in the Cargo net hook as shown.
- (b) Verify the panels fit together properly with no uneven gaps between them.
- (c) Install the deck trim cover. (Fig. 6-2)

- (d) Install the deck board and deck box.(Fig. 6-3)

7. Reconnect Battery Cable.

- (a) Reconnect the vehicle's negative battery cable. (Fig. 7-1)
 - (1) Position the negative terminal to the battery as shown (original factory position.).
 - (2) Tighten the nut to 4.1 N·m (36 lbf·in).
 - (3) Do not touch the positive terminal with any tool when installing the cable.
- (b) Clean up and remove any trash.
- (c) Place the owner "XM Satellite Radio" brochure in the glove box.
- (d) Perform the XM RID registration process.

TOYOTA Corolla 2009 - XM SATELLITE RADIO
Checklist - these points **MUST** be checked to ensure a quality installation.

Check:

Look For:

Accessory Function Checks

Satellite radio tuner.

*Verify the proper operation of the satellite radio tuner.

Receiver/player assembly.

*Verify the proper operation of the receiver/player assembly.

*(Refer to the receiver assembly and radio owner's manuals.)