

Preparation

Part Number: PT545-00082

Kit Contents

Item #	Quantity Reqd.	Description
1	1	Unit Assembly Kit
2	1	Mounting Kit
3	1	Hardware Bags
4	1	Unit and Fit Kit List
5	1	Owner's Manual

Unit Assembly Kit Contents

Item #	Quantity Reqd.	Description
1	1	Interface Kit

Mounting Kit Contents

Item #	Quantity Reqd.	Description
1	1	iPod Cable
2	1	Grommet

Hardware Bag Contents

Item #	Quantity Reqd.	Description
1	1	Foam Sleeve
2	4	2x4 inch Adhesive Protective Foam
3	4	14 inch Lock Tie
4	2	6 inch Lock Tie

Conflicts

XM or Sirius Satellite Radio

Requirement

SAT Ready Head Unit

Recommended Tools

Personal & Vehicle Protection	Notes
Safety Goggles	
Seat Covers	
Special Tools	
Panel Clip Remover	
Sockets	10 mm, 8 mm
Screwdriver	Phillips, #2
Torque Wrench	4.1 N•m (36lbf-in) (battery cable) 10 N•m (7ft-lbf)
Hole Saw	1 1/8 inch (29 mm)
De-burring Tool	
Installation Tools	Notes
Tape Measure/Ruler	Metric/Standard
Side Cutters	
Masking Tape	
Special Chemicals	Notes
Cleaner	3M™ Prep Sol-70

NOTE: Part number of this accessory may not be the same as the part number shown.

General Applicability

Note:-

Recommended Sequence of Application





Item #	Accessory
1	Security System
2	RES
3	EC Rearview Mirror
4	iPod Interface

*Mandatory

Vehicle Service Parts (may be required for reassembly)

Item #	Quantity Reqd.	Description
1		
2		
3		

Legend

	STOP: Damage to the vehicle may occur. Do not proceed until process has been complied with.
	OPERATOR SAFETY: Use caution to avoid risk of injury.
	CAUTION: A process that must be carefully observed in order to reduce the risk of damage to the accessory/vehicle and to ensure a quality installation.
	TOOLS & EQUIPMENT: Used in Figures calls out the specific tools and equipment recommended for this process.
	REVISION MARK: This mark highlights a change in installation with respect to previous issue.

Parts Description of Interface Kit Assy.

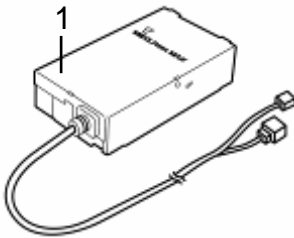

Item #	Part Name	Part No.	Qty
1	Interface Kit	PT545-00082	1

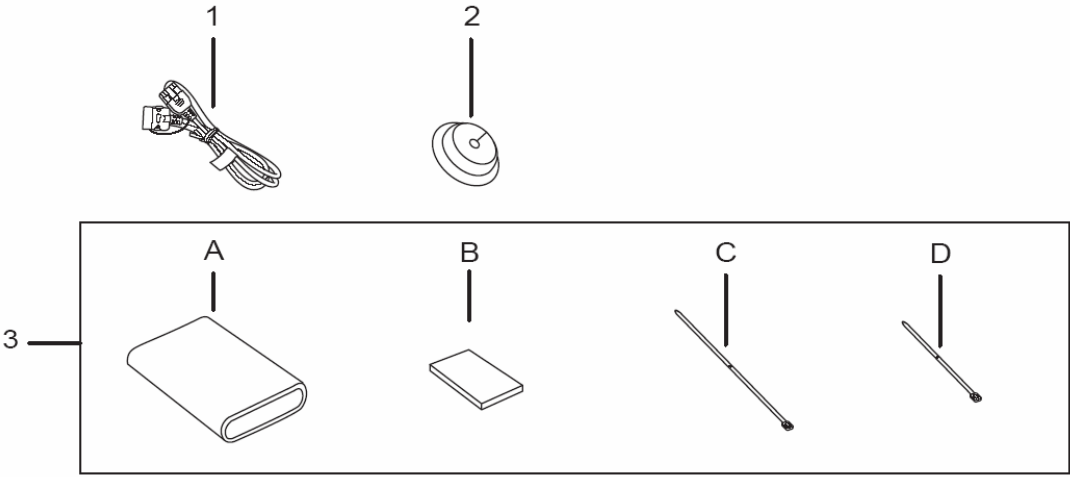

Parts Description of Mounting Kit (PT545-00082)

Item #	Part Name	Qty
1	iPod Cable	1
2	Grommet	1
3	A Foam Sleeve	1
	B 2x4 inch Adhesive Protective Foam	4
	C 14 inch Lock Tie	4
	D 6 inch Lock Tie	2

Procedure

Care must be taken when installing this accessory to ensure damage does not occur to the vehicle. The installation of this accessory should follow approved guidelines to ensure a quality installation.

These guidelines can be found in the "Accessory Installation Practices" document.

This document covers such items as:

- Vehicle Protection (use of covers and blankets, cleaning chemicals, etc.).
- Safety (eye protection, rechecking torque procedure, etc.).
- Vehicle Disassembly/Reassembly (panel removal, part storage, etc.).
- Electrical Component Disassembly/Reassembly (battery disconnection, connector removal, etc.).

Please see your Toyota dealer for a copy of this document.

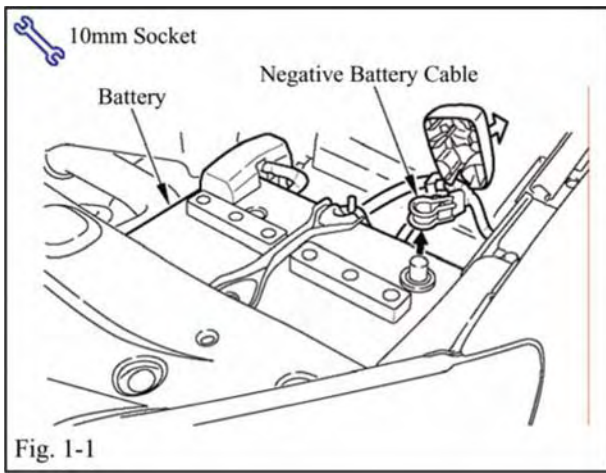

1. Vehicle Protection.

- (a) Place driver seat in mid position.
- (b) Set emergency brake.
- (c) Remove the negative battery cable. (Fig. 1-1)



(1) Protect the fender before starting.



CAUTION: Do not touch the positive terminal with any tool when removing cable.



(d) Using protective blankets cover front seats, interior of vehicle and center console and front side of the shift lever.



(e) Wait 90 seconds before proceeding to disassemble vehicle.

2. Disassembly of Vehicle.



NOTE: Place all removed parts on a protected surface.



NOTE: When disconnecting wiring connectors, do not pull on the wiring; pull on the connector only.

(a) Remove air conditioning control assembly (L,R). (Fig. 2-1)

(1) Apply protective tape.

(2) Using a panel remover, disengage the four (4) clips and remove the air conditioning control assembly.



NOTE: Tape up the screwdriver tip before use.

(3) Disconnect the two (2) connectors.

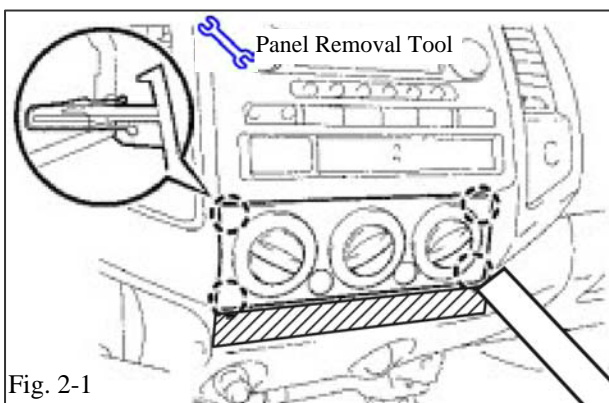



(b) Remove radio receiver assembly. (Fig. 2-2)

- (1) Remove the four (4) bolts.
- (2) Disconnect the connector and remove the radio receiver assembly with bracket.

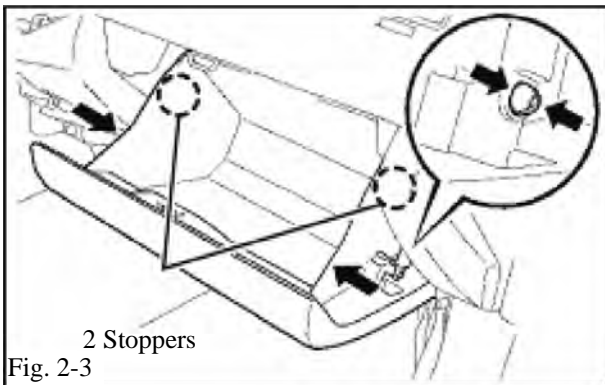

(c) Remove glove box door assembly. (Fig. 2-3)

- (1) Disengage the claw and separate the glove box door stopper from the glove box door assembly.
- (2) Slightly deform the upper part of the glove box door assembly to release the two (2) stoppers and open the glove box door assembly until it becomes horizontal.

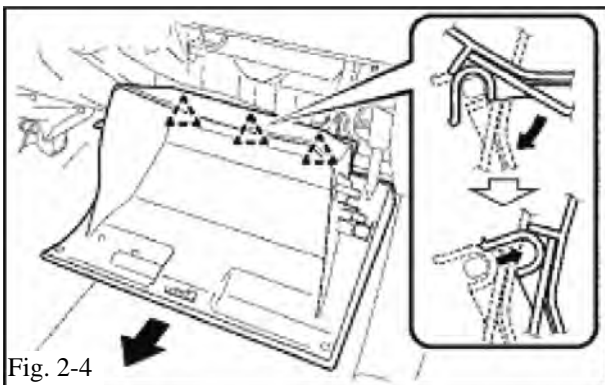

- (3) Pull the glove box door assembly toward the rear of the vehicle to release the three (3) hinges and remove the glove box door assembly. (Fig. 2-4)

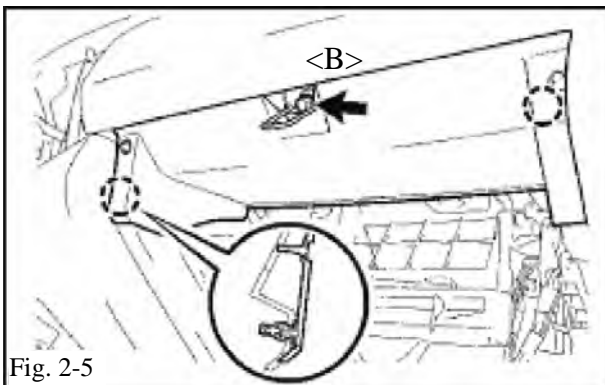

(d) Remove instrumental panel lower finish panel sub-assembly RH. (Fig. 2-5)

- (1) Remove the bolt .
- (2) Disengage the two (2) clips and remove the instrument panel lower finish panel sub-assembly RH.

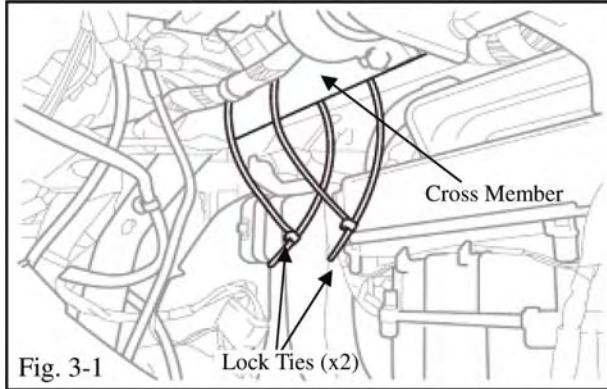

3. Install and Route the Interface Unit.

- (a) Locate the pipe-shaped cross member behind the glove box.
- (b) Place two (2) 14” lock ties around the cross member as shown. (Fig. 3-1)

NOTE: Do not tighten the lock ties.

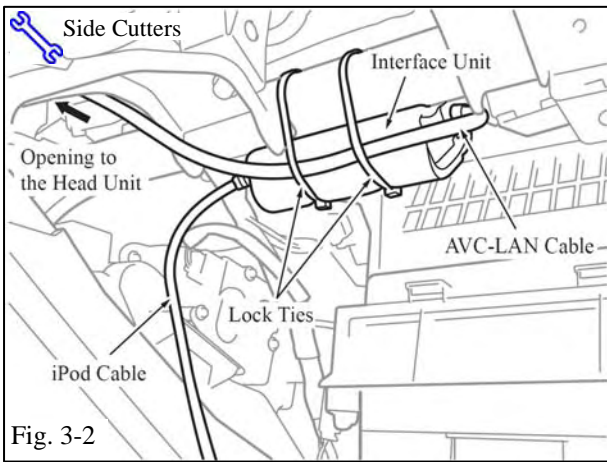

- (c) Install the foam sleeve over the interface unit.
- (d) Connect the iPod cable to the interface unit. (Fig. 3-2)
- (e) Slide the interface unit through the 14” lock ties, keeping the AVC-LAN cable on the right. (Fig. 3-2)
- (f) Route the AVC-LAN cable along the interface unit under the cross member to the head unit.
- (g) Tighten the two (2) 14” lock ties and secure the interface unit and the AVC-LAN cable. (Fig. 3-2)

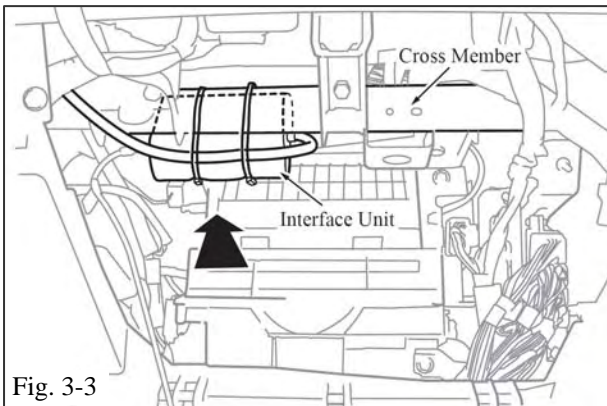

- (1) Make sure the cable is not bent too tightly or kinked.
- (h) The interface unit should fit securely in place forward of the vehicle cross member pipe, parallel to the floor of the vehicle. (Fig. 3-3 and 3-4)

NOTE: Trim excess from all lock ties after tightening. Ensure the lock ties are not interfering with any panels, harnesses or brackets.

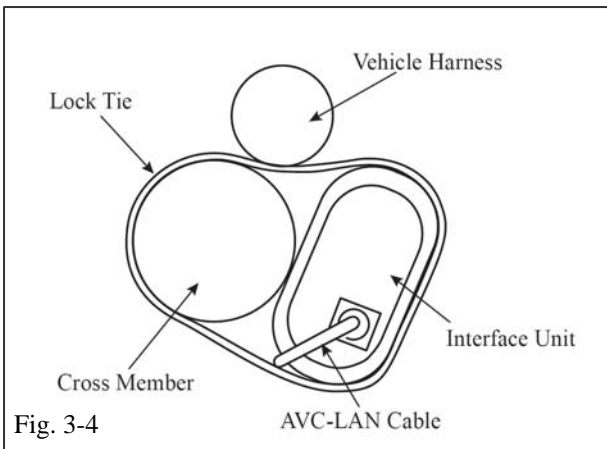

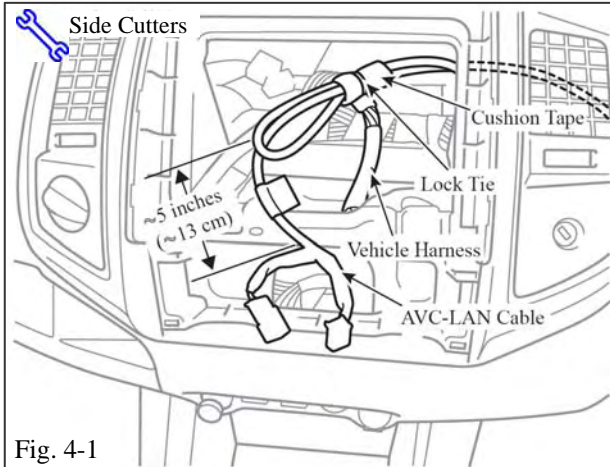

4. Connect the AVC-LAN Cable to the Head Unit.

- (a) Bundle the excess AVC-LAN cable and secure to the vehicle harness behind the head unit using the cushion tape and one (1) 14" lock tie. (Fig. 4-1)

NOTE: Cut off all excess of lock ties after tightening.

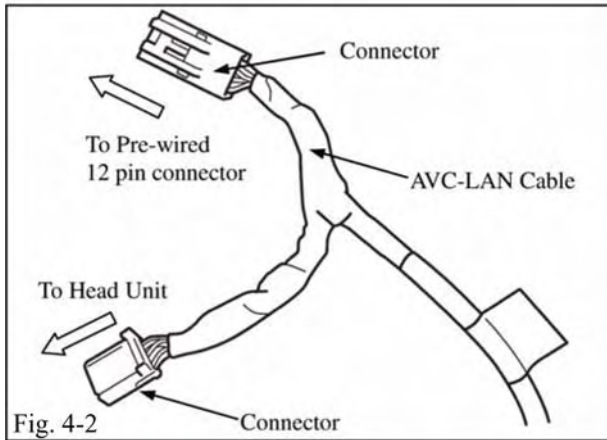

NOTE: If the 12 pin connector is already pre-wired to the head unit, proceed to step (b). If the 12 pin connector is not pre-wired to the head unit, proceed to step (c).

- (b) If the 12 pin connector is already pre-wired to the head unit.
 - (1) Remove the pre-wired 12 pin connector from the head unit.
 - (2) If applicable, plug the pre-wired 12 pin connector into the connector of the AVC-LAN cable. (Fig. 4-2 & 4-3)

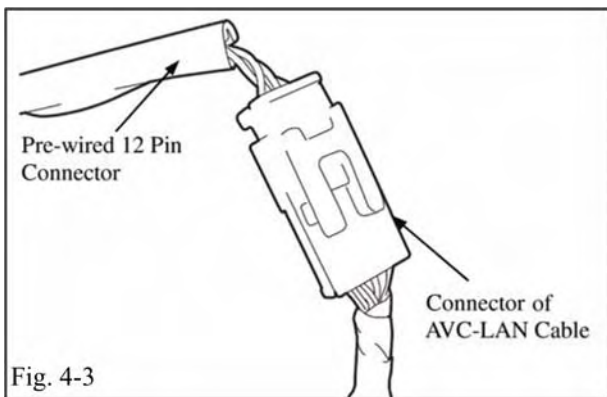

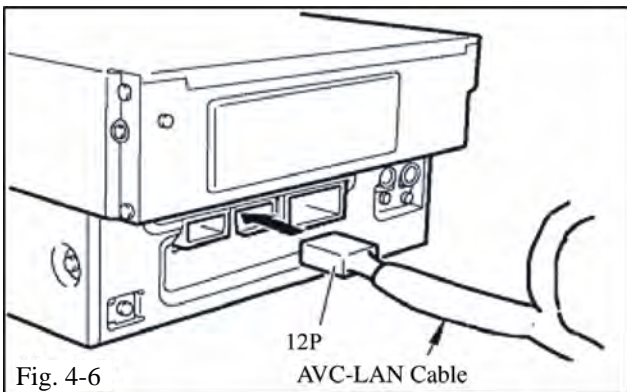
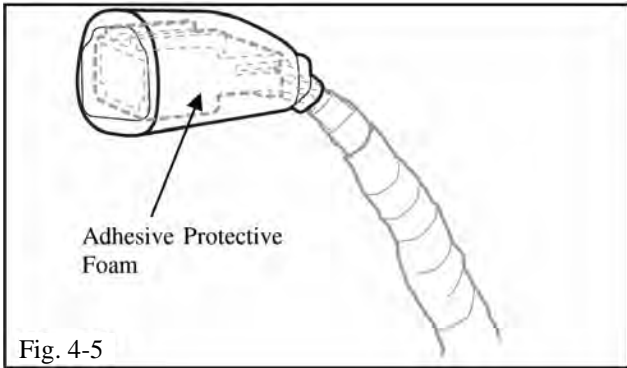
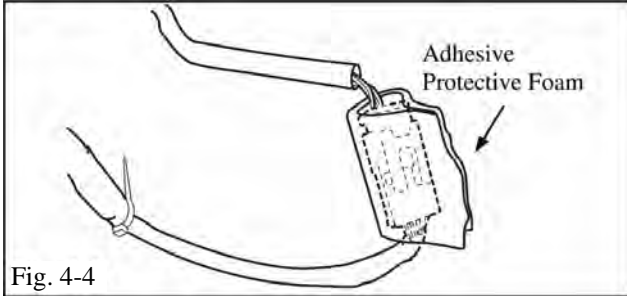

- (3) Wrap the connectors with adhesive protective foam to secure. (Fig. 4-4)
- (4) Reconnect the factory harness and antenna cable.

(c) If the 12 pin connector is not pre-wired to the head unit.

- (1) Wrap the unused connector of the AVC-LAN cable in adhesive protective foam. (Fig. 4-5)
- (2) Reconnect the factory harness and antenna cable.

(d) Plug the connector of the AVC-LAN cable into the head unit. (Fig. 4-6)

(e) Reinstall head unit.

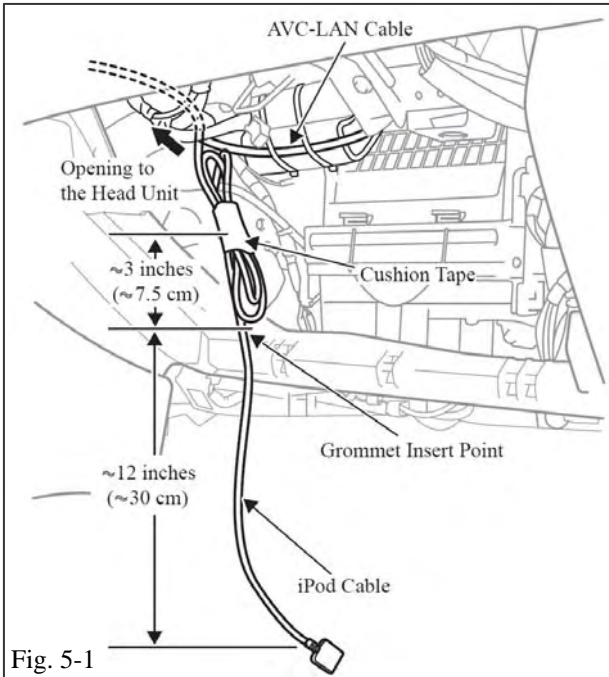

5. Route the iPod Cable.

- (a) Bundle the excess iPod cable and secure with cushion tape. (Fig. 5-1)
 - (1) Provide sufficient iPod cable length so 12 inches of cable will be in the glove box after installation.

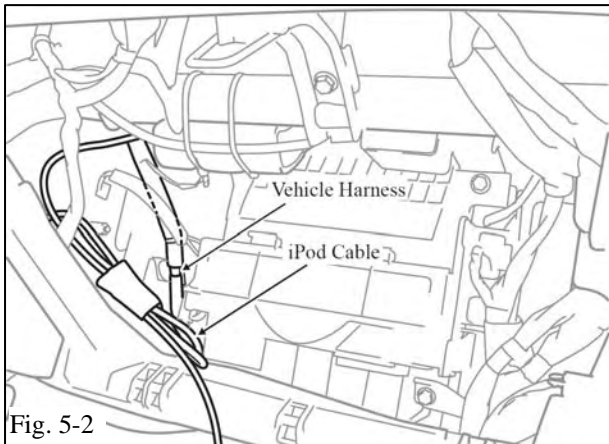

- (b) Using one (1) 6" lock tie, secure the cable bundle to the existing vehicle harness behind the glove box. (Fig. 5-2 and 5-3)

NOTE: Cut off all excess of lock ties after tightening.

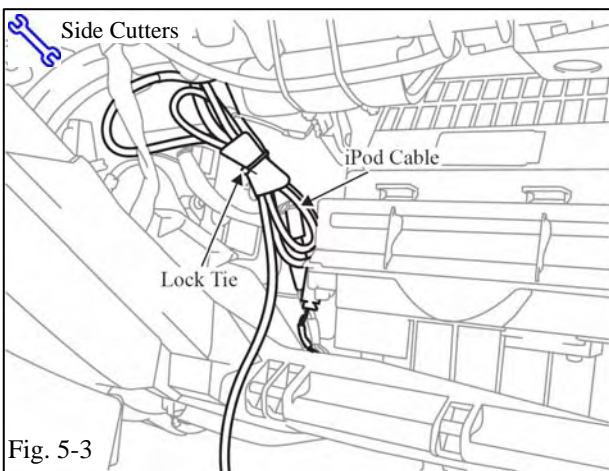

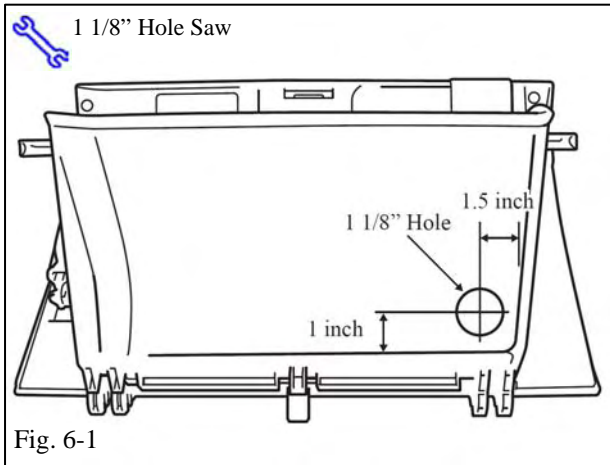

6. Route the iPod Cable Terminal.

- (a) Make a round hole through which the cable can pass at the location on the glove box shown in the illustration. (Fig. 6-1)
 - (1) Hole saw is 1 1/8" (29 mm).
 - (2) De-bur drilled hole.
 - (3) Clean shavings from glove box after drilling.

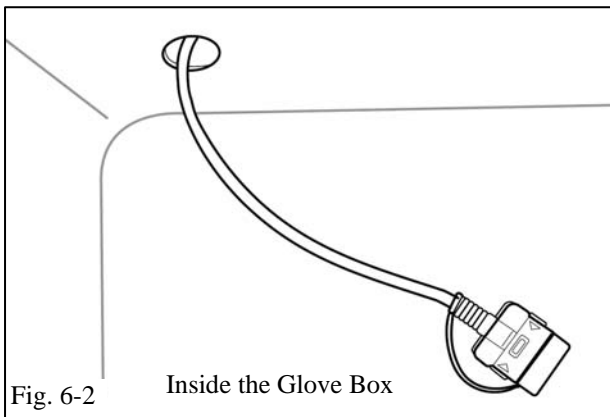

- (b) Route the iPod cable through the hole and into the glove box. (Fig. 6-2)

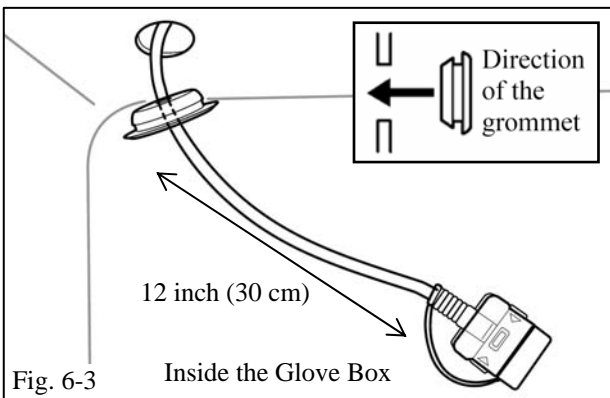

- (c) Apply the grommet to the iPod cable. The distance from the grommet to the iPod connector terminal should be approx. 12 inches. (Fig. 6-3)

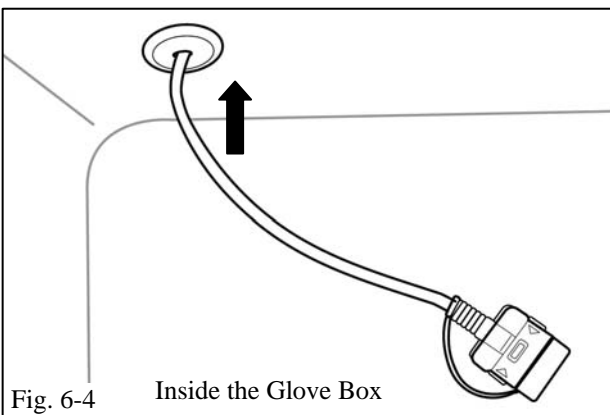

- (d) Secure the grommet to the hole from the inside of the glove box. (Fig. 6-4)

NOTE: The inside of the glove box should look like Fig. 6-4.

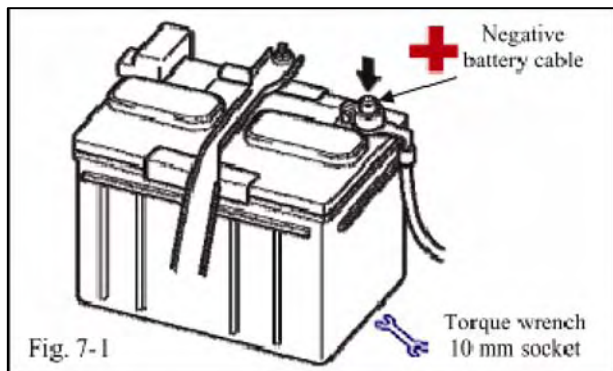

7. Vehicle Reassembly.

(a) Reconnect any disconnected connectors.



(b) Verify that panels fit together properly with no uneven gaps between them.

(c) Reinstall negative battery cable. (Fig 7-1)

Specified tightening torque:

4.1 N·m (36 lbf-in)



CAUTION: Do not touch the positive terminal with any tool.

(d) Place the owner's manual in the glove box.

(e) Clean up and remove any trash.

(f) Proceed to functional verification.

TOYOTA TACOMA 2008 - INTERFACE KIT FOR IPOD
Checklist - these points **MUST** be checked to ensure a quality installation.

Check:

Accessory Function Checks

- Interface Kit

- Receiver/player Assembly

Look For:

- *Verify the proper connection of the Interface kit.

- *Verify the proper operation of the Receiver/player Assembly.

- *Verify both AM & FM have good reception.

- *(Refer to the receiver assembly and radio owner's manuals.)

Vehicle Function Checks

- Audio AM/FM

- Hazard Switch

- HVAC

- Multi-information displays (Clock, Temp., and MPG meter)

- Operation of the 12V outlet switch

- Verify the proper operation of audio AM/FM.

- Verify the proper operation of the hazard switch.

- Verify the proper operation of the air conditioning system.

- Verify the proper operation of the multi-information displays.

- Verify the proper operation of the 12V outlet switch.