

Part Number: PT47A-21053-XX
PT47A-21063-XX
PT47A-21083-XX

NOTE: Part number of this accessory may not be the same as the part number shown.

Kit Contents

Item #	Quantity Reqd.	Description
1	1	Painted Front Skirt
2	1	Painted LH Side Skirt
3	1	Painted RH Side Skirt
4	1	Painted LH Rear Skirt
5	1	Painted RH Rear Skirt
6	1	Master Hardware Bag

Hex Nut Driver	10 mm
Nylon Removal Tool	e.g. Panel Pry Tool #1 Toyota SST # 00002-06001-01
Screwdriver	Phillips Head #2
Small Parts Bin	
Special Chemicals	Notes
Soap/Water Solution	

Hardware Bag Contents

Item #	Quantity Reqd.	Description
1	1	Installation Instructions
2	1	Front Skirt Hardware Bag
2a	6	White Retainer T-Clips
3	1	Side Skirt Hardware Bag
3a	12	Black Retainer Pins
4	1	Rear Skirt Hardware Bag
4a	8	White Retainer T-Clips
4b	6	Black Push Pins
4c	4	Black Wire Ties

General Applicability

All Scion tC Models

Recommended Sequence of Application

Item #	Accessory
1	
2	
3	

*Mandatory

Additional Items Required For Installation

Item #	Quantity Reqd.	Description
1		
2		
3		

Vehicle Service Parts (may be required for reassembly)

Item #	Quantity Reqd.	Description
1		
2		





Conflicts

Mud Guards

Recommended Tools

Personal & Vehicle Protection	Notes
Wrist and Belt Buckle Protectors	
Blankets	
Shop Rags	
Masking Tape	
Special Tools	Notes
Router	Router such as Dremel Rotozip with 1/8" Router Bit or Equivalent
Installation Tools	Notes
Drill Motor	3/8"
Twist Drill Bit	3/16", 5/16", 1/4"
Router Bit	1/8"
Clip Removal Tool	

Legend

	STOP: Damage to the vehicle may occur. Do not proceed until process has been completed with.
	OPERATOR SAFETY: Use caution to avoid risk of injury.
	CAUTION: A process that must be carefully observed in order to reduce the risk of damage to the accessory/vehicle and to ensure a quality installation.
	TOOLS & EQUIPMENT: Used in Figures calls out the specific tools and equipment recommended for this process.

Care must be taken when installing this accessory to ensure damage does not occur to the vehicle. The installation of this accessory should follow approved guidelines to ensure a quality installation.

These guidelines can be found in the "Accessory Installation Practices" document.

This document covers such items as:-

- Vehicle Protection (use of covers and blankets, cleaning chemicals, etc.).
- Safety (eye protection, rechecking torque procedure, etc.).
- Vehicle Disassembly/Reassembly (panel removal, part storage, etc.).
- Electrical Component Disassembly/Reassembly (battery disconnection, connector removal, etc.).

Please see your Toyota dealer for a copy of this document.

NOTE: Raise or lower vehicle on hoist as appropriate.

1. Bumper Removal (Front)

- (a) Clean the front and rear bumpers with a solution of soap and water.
- (b) Remove the three (3) screws. (Fig. 1-1)
NOTE: It is not necessary to fully remove the fender liner. Partially remove it so that it does not hang up on the bumper cover when it is removed. Repeat the same process for the opposite side.
- (c) Remove the three (3) lower screws and two (2) fender well bolts. (Fig. 1-2)
- (d) Using a clip remover, remove the clip labeled A and two (2) clips labeled B, and two (2) protectors. (Fig. 1-2)
- (e) Put protective tape under the front fender. (Fig. 1-3)
- (f) Gently pull the corner of the bumper cover away from the vehicle and disengage the three (3) claws labeled A and one (1) claw labeled B. Repeat the process for the opposite side and remove the bumper cover. (Fig. 1-3)

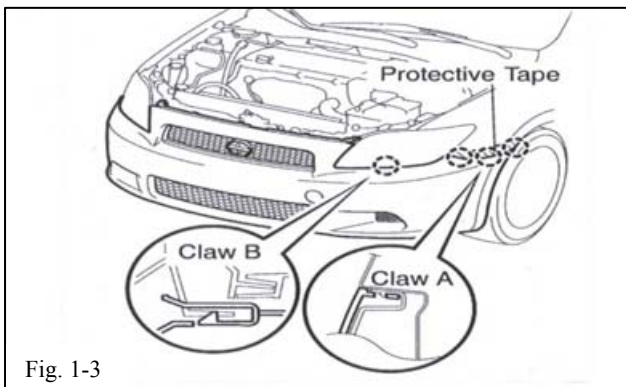
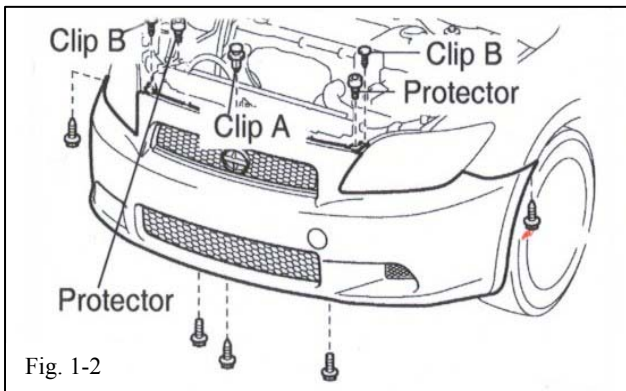
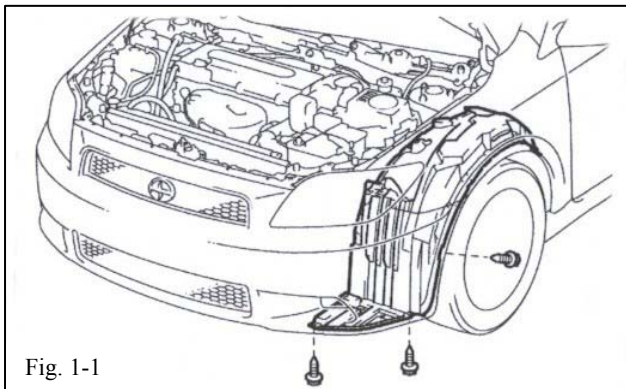

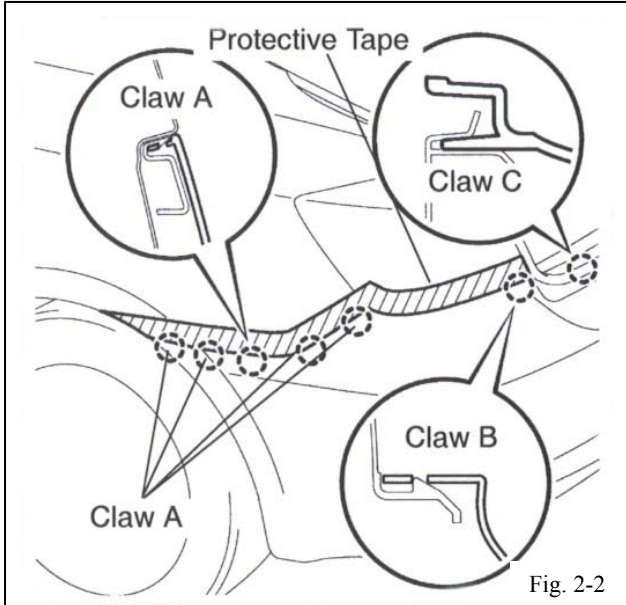
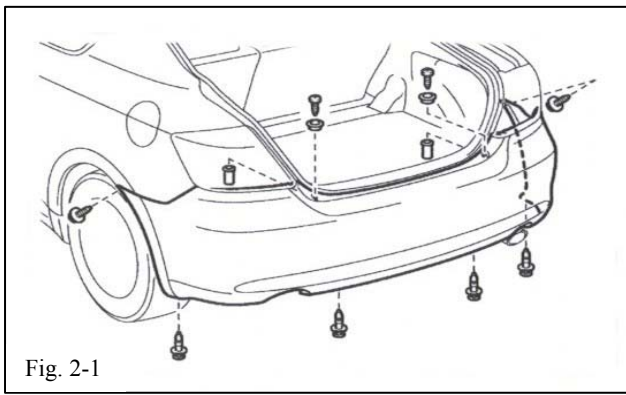

2. Bumper Removal (Rear)

- (a) Remove the four (4) lower pushpins and two (2) fender well screws. (Fig. 2-1)
- (b) Remove the two (2) upper bumper cover screws along with the plastic screw hats. (Fig. 2-1)
- (c) Put protective tape under the quarter panel.
- (d) Gently pull the corner of the bumper cover away from the vehicle and disengage the ten (10) claws labeled A, the two (2) claws labeled B, and the two (2) claws labeled C. Repeat the process for the opposite side and remove the bumper cover. (Fig. 2-2)

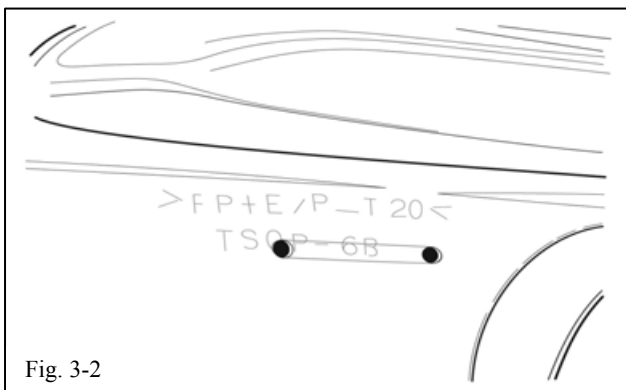
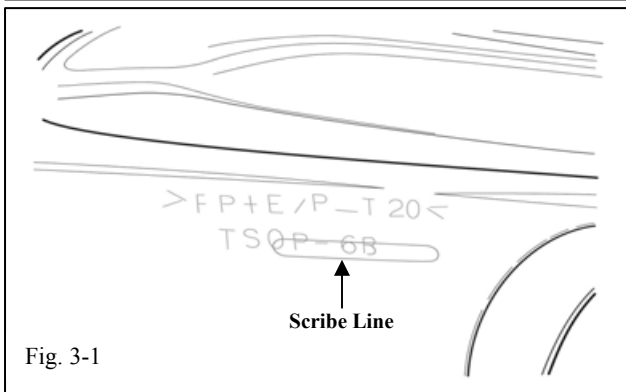

3. Slot Cutting

- + (a) Eye protection must be worn during all slot cutting and hole drilling.
- (b) With the bumper covers off the vehicle, look for slot scribe lines on the inside of the bumper covers. (Fig. 3-1) Front bumper cover has six (6) slots to be cut. Rear bumper cover has eight (8) slots to be cut. (Five (5) slots to the left of the muffler tip, three (3) slots to the right of the muffler tip.)

NOTE: If you have difficulty in locating the slot scribe lines, hold the front and rear ground effects skirts up to each bumper cover and note where the tabs are that align with the slots.)

- (c) Drill a 1/4" diameter hole at each end of each of the fourteen (14) slots to be cut. (Fig.3-2)

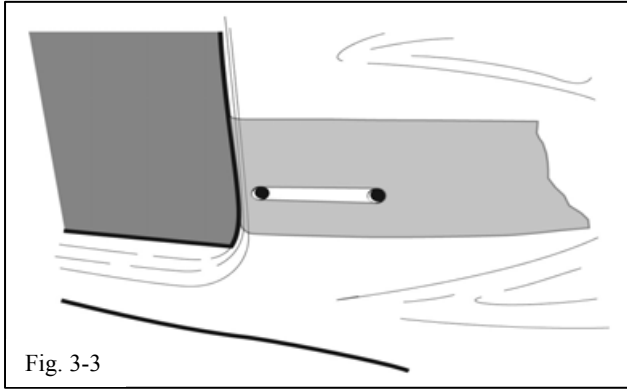

Fig. 3-3

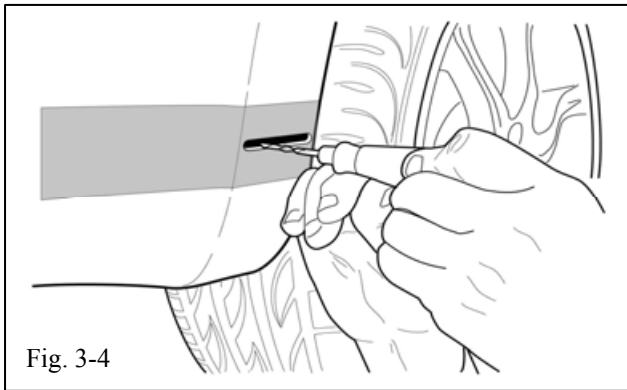

Fig. 3-4



- (d) On the painted surface of the bumper covers, apply masking tape over each set of 1/4" holes marking the ends of the slots. (Fig. 3-3) Using the top and bottom of each hole, scribe a horizontal line showing where to cut the slots.
- (e) Reinstall the front and rear bumper covers except for the fasteners on the bottom of the front and rear covers.
- (f) Using the router with a 1/8" diameter bit inserted into one of the 1/4" holes, carefully and slowly cut the rest of each slot. (Fig. 3-4) When properly cut, the slots should be 1/4" wide and have clean smooth edges.

DO NOT MAKE THE SLOTS OVERSIZED.

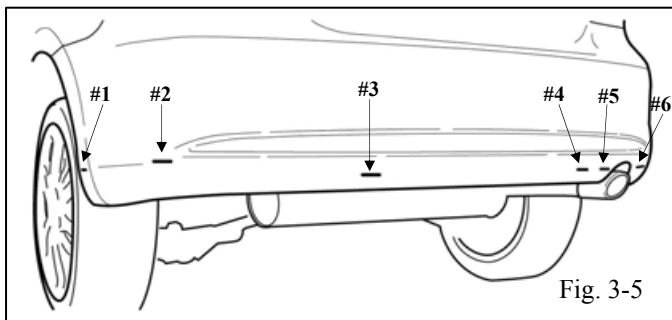

Fig. 3-5

- (g) A 3/16" diameter hole needs to be drilled above slot #3 and slot #4 (Fig. 3-5) shown in (Fig. 3-6).
- (h) When properly cut, all of the slots in the bumper will have clean edges.

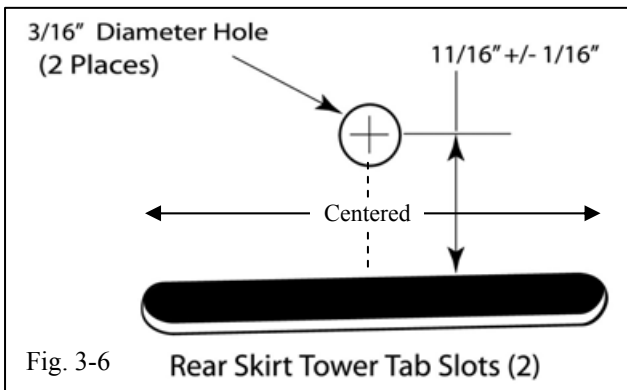
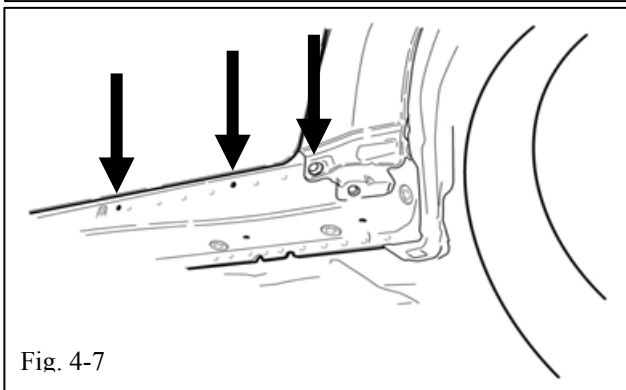
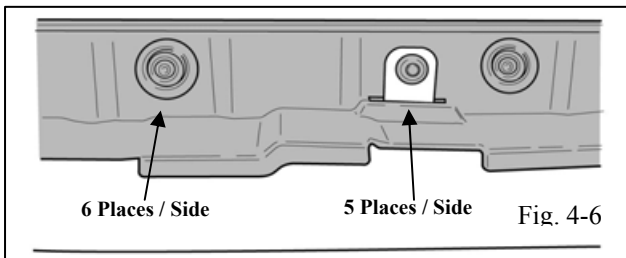
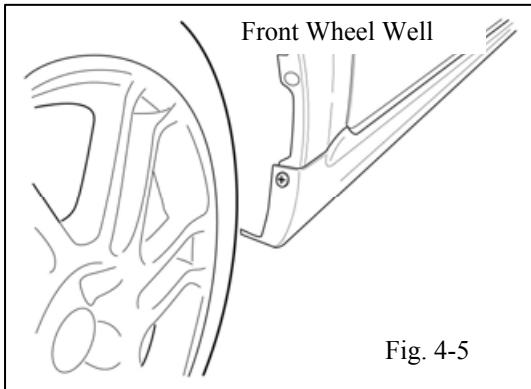
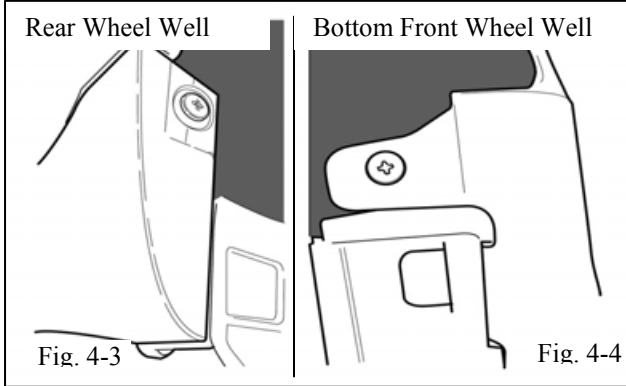
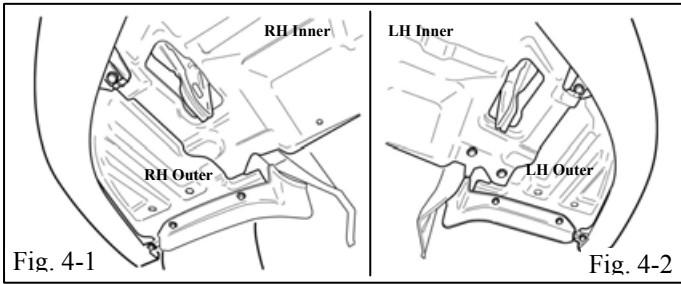

Fig. 3-6

Rear Skirt Tower Tab Slots (2)



4. Final Vehicle Disassembly

- (a) Remove all of the fasteners in the inner LH & RH splash shield. Remove the two inner splash shields. It is not necessary to remove the outer LH & RH splash shields (Figs. 4-1 & 4-2)
- (b) To remove the LH & RH side skirts, start by removing the Phillips head screw at each end inside the wheel well opening (Figs. 4-3, & 4-5). Remove the screw located at the bottom of the front wheel well (Fig. 4-4).
- (c) Next, remove and save five black plastic clips along the bottom of each side skirt and save for reinstallation. (Fig. 4-6)
- (d) Finally, remove the six (6) large plastic plugs from the bottom of each side skirt. Do not discard these plugs, as they will be reinstalled.
- (e) Lower the vehicle until the side skirts are at waist height.
- (f) The side skirts can now be removed from each side of the vehicle by first opening the doors and prying along the top edge with a nylon trim removal tool starting at the front and working toward the rear. If any of the six (6) white plastic clips on each side remain attached to the vehicle, remove and discard them. (Fig. 4-7)
- (g) With the original side skirts off the vehicle, you will find a two-piece mud shield inside each skirt. Remove these mud shields. They will be reinstalled on the new side skirts. Pay close attention to how they attach and keep the LH & RH parts separate. Each of the mud shields has a front and rear segment and they are not interchangeable.

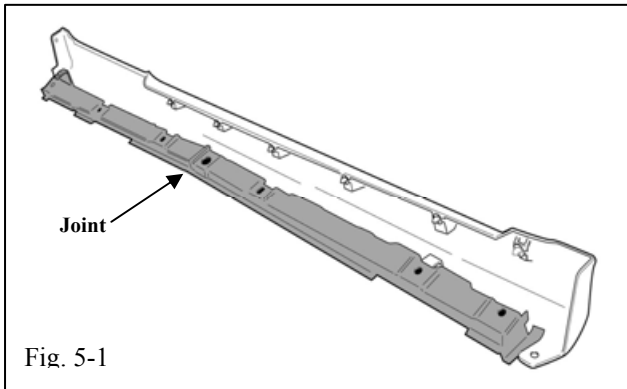

5. Attaching the Ground Effects Skirts.

- (a) Reinstall the mud shields in the new **side skirts**. (Fig. 5-1)
- (b) With the vehicle still at waist height and the doors open, place the new side skirts in position. Make certain that all six of the new white clips in each skirt are aligned with the corresponding holes in the body and then press in along the length to snap to the body. (Fig. 5-1)
- (c) Raise the vehicle again and reinstall the five black plastic clips in the bottom of the new side skirts along with the previously removed six plastic plugs. Note that these fasteners hold both the new side skirts, and the old reused mud shields. Finally, reinstall the three Phillips screws removed in Step 4. (b) in each of the new side skirts.

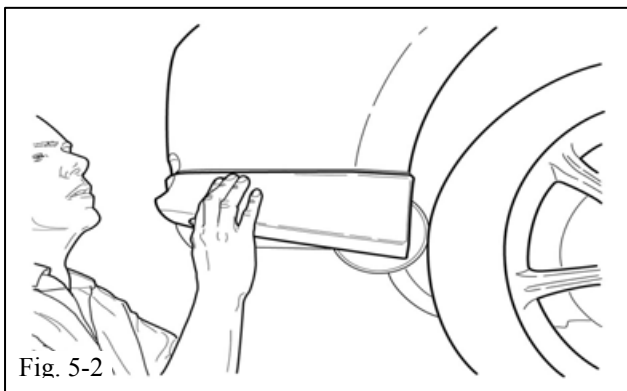

- (d) Position the **RH rear skirt** at the rear RH corner of the bumper cover and align the three mounting tabs with the slots cut in the bumper. Press the tabs into the slots until they snap in place. (Fig. 5-2)

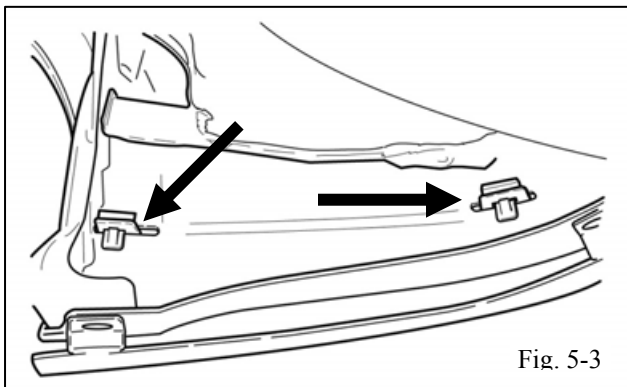

- (e) From inside the rear bumper cover, install the three white T-Clips in the slots in the tabs that protrude through the cut bumper cover slots. Be sure to install the T-clips with the spring tabs facing away from the inside of the bumper cover. The T-clips will snap in place and lock the skirt to the bumper. (Fig. 5-3) (NOTE: Fig. 5-3 shows only two of the T-clips – see Fig. 5-6 for location of third T-clip.)

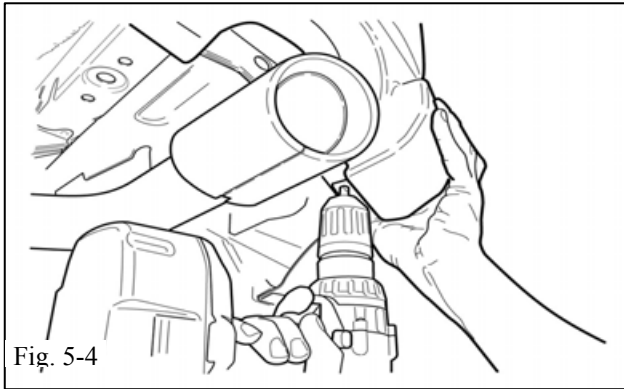

(f) There is a tab with a living hinge on the end next to the exhaust tip. While holding the tab up against the bottom of the rear bumper cover, drill a 5/16" hole in the bottom of the rear bumper using the hole in the tab as a drill locator. (Fig. 5-4)

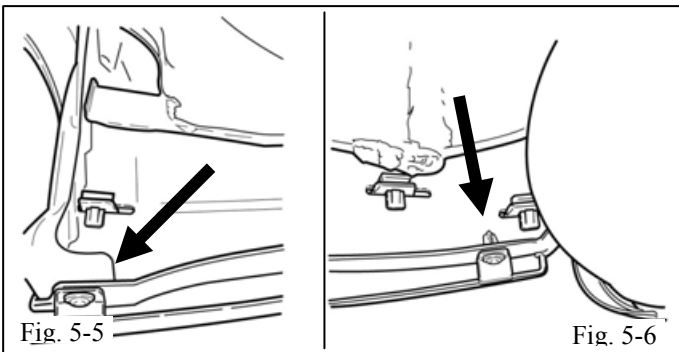

(g) Install the two black plastic push clips in the tabs on the bottom of the skirt. These clips hold the bottom of the skirt to the bumper. (Figs. 5-5 & 5-6)

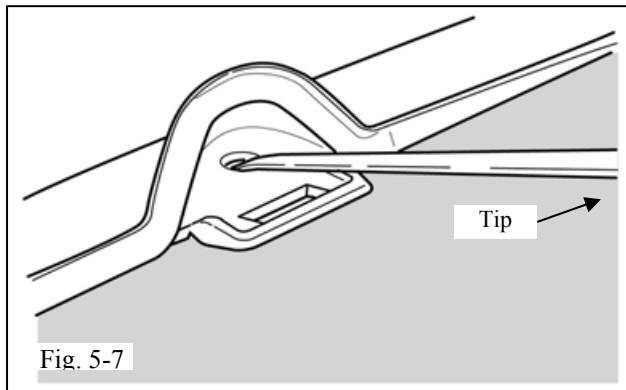

(h) On the **LH rear skirt**, thread the tip of a black cable tie up through the hole in the surface behind the slotted tabs. Do this in two places. (Fig. 5-7)

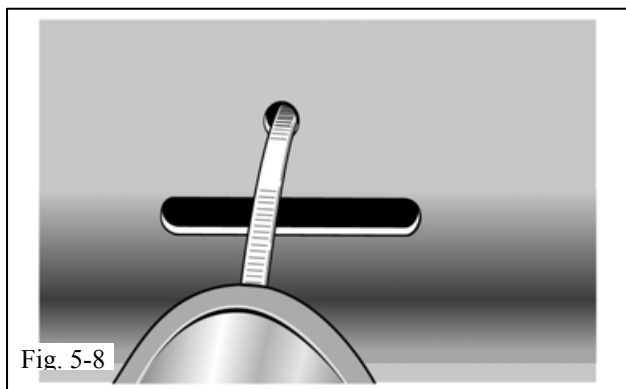

(i) Position the LH rear skirt at the rear LH corner of the bumper and align the five mounting tabs with the slots cut in the bumper. While holding it in place, thread the tip of the two black cable ties through the holes drilled in Step 3. (g) above two of the cut slots. (Fig. 5-8) Snap all five tabs into the cut slots.

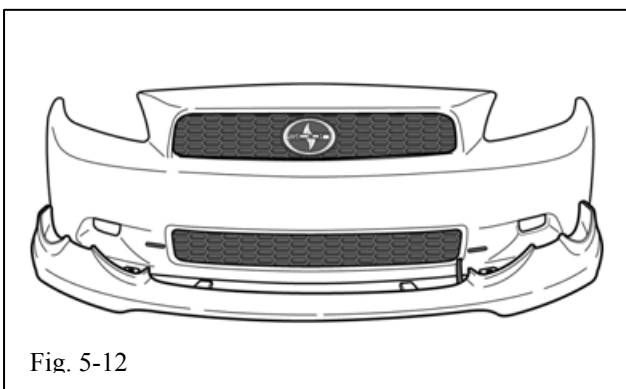
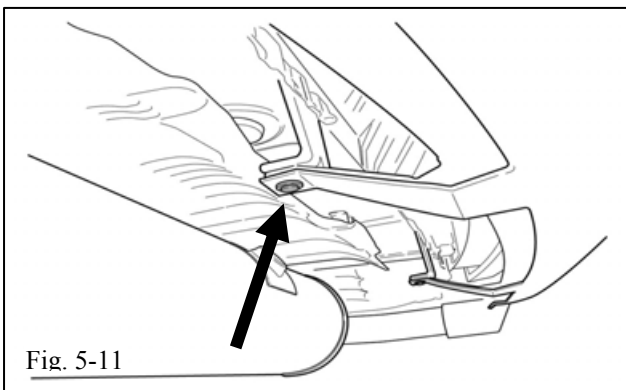
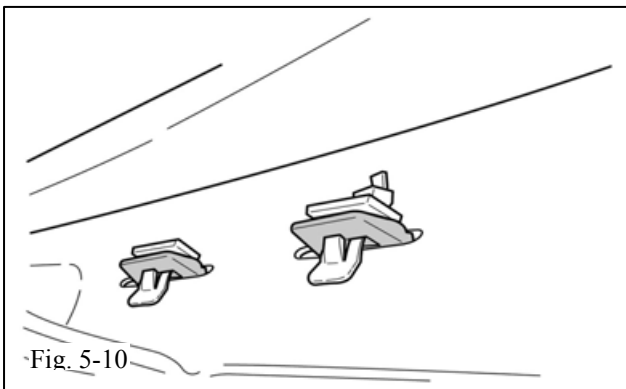
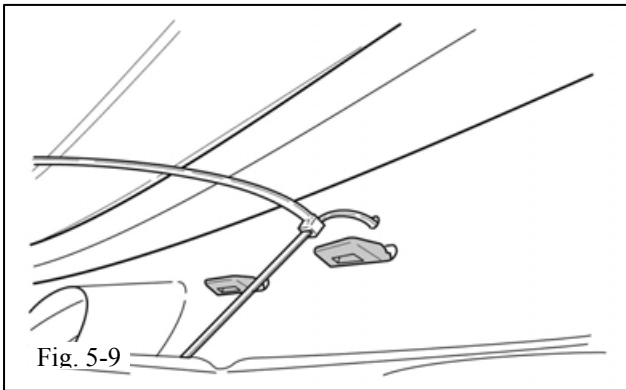

- (j) Slide a second cable tie onto each of the cable ties protruding through the bumper cover and tighten snugly. (Fig. 5-9)
- (k) Clip the ends of all four cable ties and then install the five white T-clips. Be sure to install the T-clips with the spring tabs facing away from the inside of the bumper cover. (Fig. 5-10)
- (l) Install black plastic push clips in each of the two long tabs. This will capture the corresponding tab on the rear bumper cover. (Fig. 5-11)
- (m) Drill a 5/16" diameter hole in the bottom of the rear bumper cover using the hole in the tab next to the exhaust tip as a guide. Install the last two black plastic push clips.
- (n) On the lower grill, clean the bottom portion of the grill opening area on the front bumper cover with soap and water solution.
- (o) Position the **front skirt** aligning the six tabs with the cut slots and snap it in place making sure the red tape pull tab sticks out above the skirt in front of the lower grill opening. (Fig. 5-12)

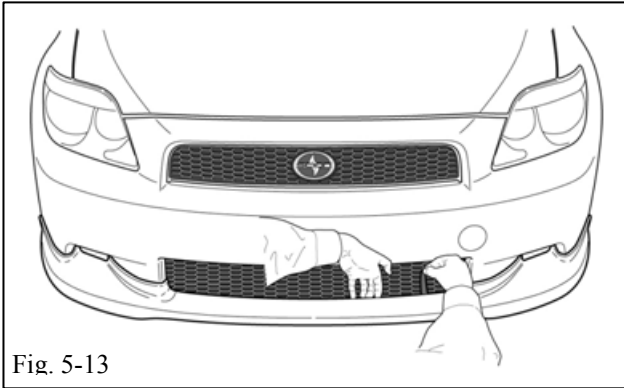

Fig. 5-13

- (p) Slightly lift the edge to pull the tape liner from the adhesive tape. Once the tape liner is completely removed, apply pressure to the entire edge of the front skirt at the grill opening to ensure good tape adhesion. (Fig. 5-13)

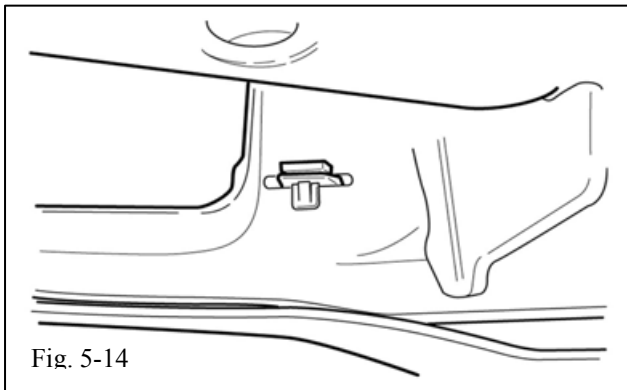

Fig. 5-14

- (q) Install the six white plastic T-clips. Be sure to install the T-clips with the spring tabs facing away from the inside of the bumper. (Fig. 5-14)

6. Reassemble the Vehicle

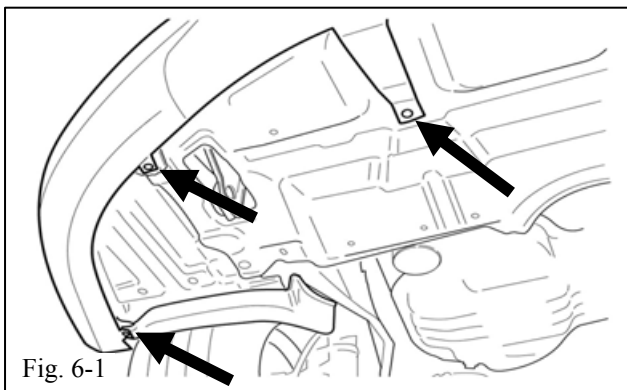

Fig. 6-1

- (a) Reinstall the front LH & RH inner splash shields. Complete by reinstalling all of the original fasteners in the bottom of the front bumper, while capturing the front skirt. (Fig. 6-1)

Checklist - these points **MUST** be checked to ensure a quality installation.

Check:

Look For:

Accessory Function Checks

Check for front and rear skirt gasket gaps.

A maximum allowable gap between the gaskets and the vehicle is ½ mm.

Vehicle Function Checks

None Required