

Part Number: PT47A-21052-XX
PT47A-21062-XX
PT47A-21082-XX

NOTE: Part number of this accessory may not be the same as the part number shown.

Kit Contents

Item #	Quantity Reqd.	Description
1	1	Painted Spoiler Assembly
2	1	LH Gas Strut
3	1	RH Gas Strut
4	1	Hardware Bag

Hardware Bag Contents

Item #	Quantity Reqd.	Description
1	4	M5 Hex Nuts

Additional Items Required For Installation

Item #	Quantity Reqd.	Description
1	1	DIO Install Kit P/N PT47A-2105P (DIO Only)

Conflicts

Satellite Radio Antenna

Recommended Tools

Personal & Vehicle Protection	Notes
Wrist and Belt Buckle Protectors	
Blankets	
Shop Rags	
Masking Tape	
Special Tools	Notes
None	
Installation Tools	Notes
Drill Motor	3/8"
Twist Drill Bit	1/8"
Twist Drill Bit	3/8"
Hole Cutter	3/4"
Drill Stops	1/8", 3/8", 3/4"
Center Punch	
Hex Nut Driver	10 mm
Deep Well Socket	10 mm
Socket Extension	3"
Ratchet	
Torque Wrench	0-100 lbf-in
Nylon Trim Removal Tool	Toyota SST # 00002-06001-01
Shop Vacuum	
Hole Deburring Tool	
Magnet With Flex Shaft	
Flat Blade Screwdriver	5 mm wide tip

Phillips Screwdriver	#2
----------------------	----

Heat Gun	
Small Parts Bin	
Scissors	
Special Chemicals	Notes
Sealant	3M Ultra-Pro Body Sealant
Cleaner	3M Prep Solvent 70

General Applicability

All Scion tC Models

Recommended Sequence of Application





Item #	Accessory
1	None
2	
3	

*Mandatory

Vehicle Service Parts (may be required for reassembly)

Item #	Quantity Reqd.	Description
1	As Required	Fastener, P/N 90467-07042-CO
2	As Required	White Panel Fastener, P/N 67771-89104

Legend

	STOP: Damage to the vehicle may occur. Do not proceed until process has been complied with.
	OPERATOR SAFETY: Use caution to avoid risk of injury.
	CAUTION: A process that must be carefully observed in order to reduce the risk of damage to the accessory/vehicle and to ensure a quality installation.
	TOOLS & EQUIPMENT: Used in Figures calls out the specific tools and equipment recommended for this process.

Care must be taken when installing this accessory to ensure damage does not occur to the vehicle. The installation of this accessory should follow approved guidelines to ensure a quality installation.

These guidelines can be found in the "Accessory Installation Practices" document.

This document covers such items as: -

- Vehicle Protection (use of covers and blankets, cleaning chemicals, etc.).
- Safety (eye protection, rechecking torque procedure, etc.).
- Vehicle Disassembly/Reassembly (panel removal, part storage, etc.).
- Electrical Component Disassembly/Reassembly (battery disconnection, connector removal, etc.).

Please see your Toyota dealer for a copy of this document.

1. Trim Panel Removal.

(a) Open the Lift Gate.



(b) Place blankets inside the cargo area and the lift gate opening. (Fig. 1-1)

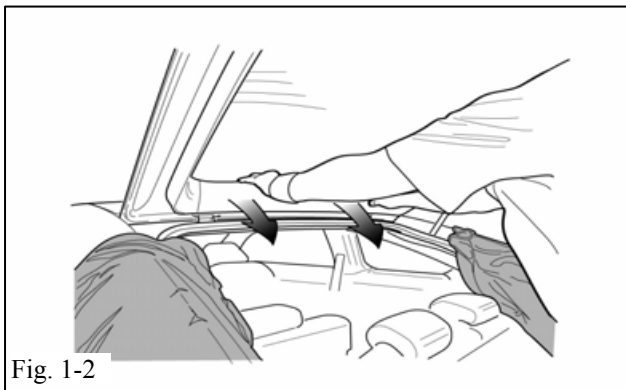

(c) Remove the trim panel across the inside of the lift gate window. (Fig. 1-2)

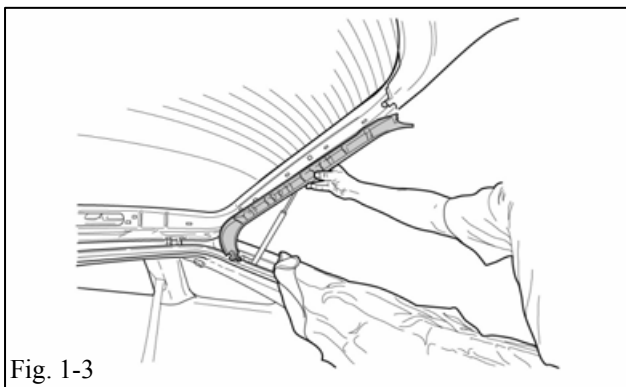

(d) Remove the LH and RH trim panels on the sides of the lift gate window. (Fig. 1-3)

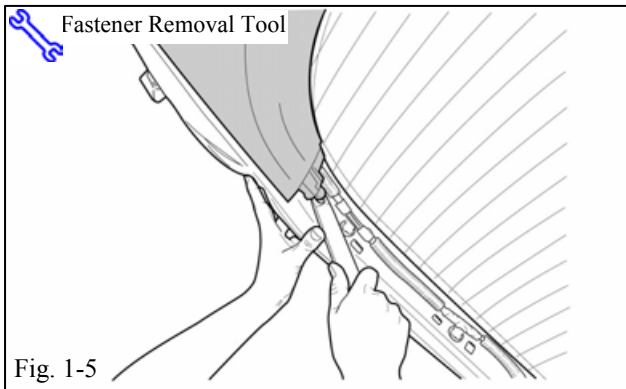
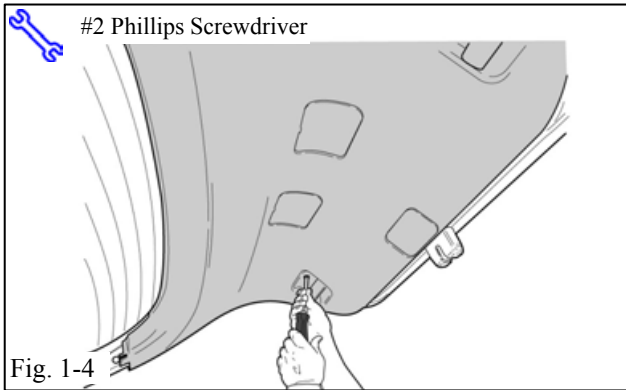

(e) Remove the two Phillips screws just above each handle pull on the lift gate trim panel. (Fig. 1-4)

(f) Remove the two fasteners at the top of the lift gate trim panel and remove the panel. (Fig. 1-5)

(g) Leave the protective blankets in place.

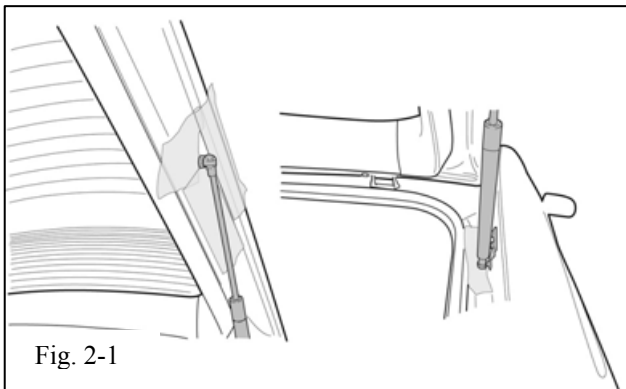

2. Gas Lift Strut Replacement.

(a) Apply protective masking tape to the painted surfaces behind the gas strut ball ends. (Figs. 2-1)

NOTE: If a helper is not available to hold the lift gate open, the lift gate **MUST** be propped open.

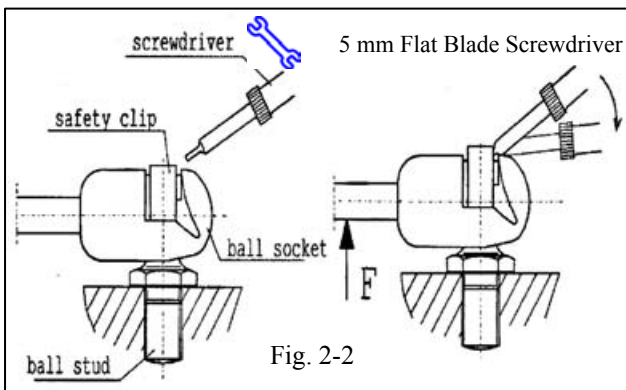

(b) Insert a 5 mm wide screwdriver into the gap between the retaining clip and the top of the ball socket. Lift the retaining clip by turning the screwdriver until the ball socket can be easily detached from the ball stud by applying a low hand force in direction shown as F. (Fig. 2-2)

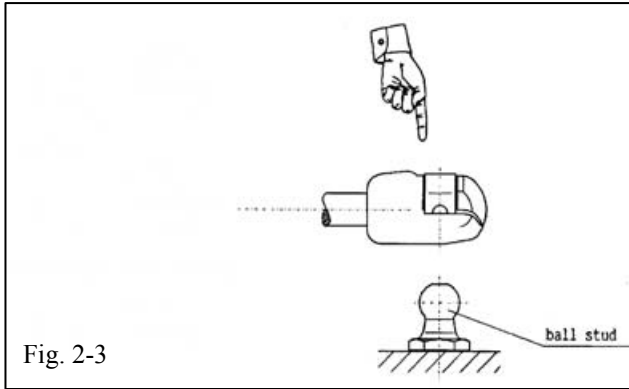

- (c) Remove and replace the LH and RH gas filled lift struts. When removing, start with the lift gate end. When installing the new struts, start with the lower end and position the ball socket onto the ball stud. Insert manually, so that the ball stud snaps in safety clip securely. Finish by snapping the upper end in place. (Fig. 2-3)

3. Hole Drilling



- (a) Eye protection must be worn during all drilling.
- (b) Set all drill stops to 1/2".
- (c) Apply masking tape to the lift gate surface in the areas of the hole locations.

NOTE: The above step is not necessary if the lift gate surface is covered with protective polywrap.

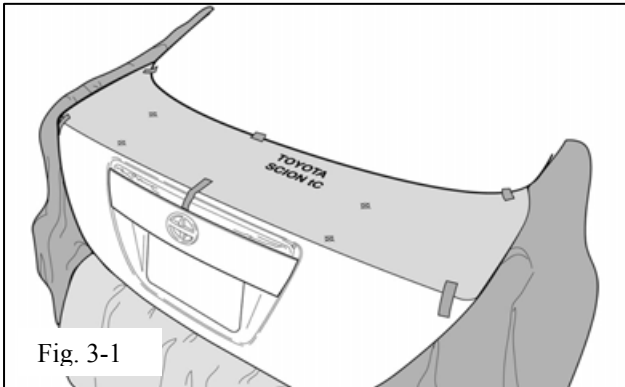

- (d) Place the drilling template on the vehicle as shown. Tape in place, making sure template is completely smooth and flat on trunk lid surface. (Fig. 3-1)

- (e) Locate the four (4) hole locations on the template.

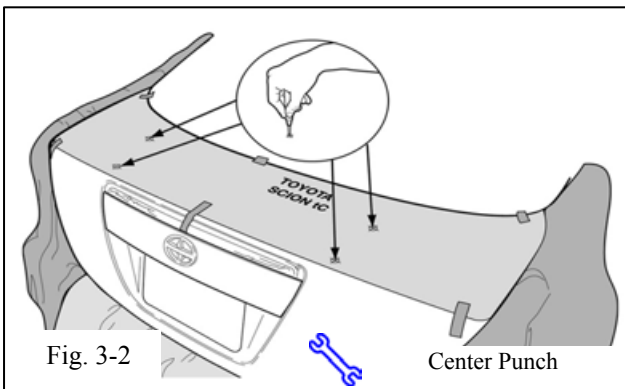

NOTE: The hole centers are punch marks within the segmented circles. The punch marks must be located and used for proper spoiler alignment.

- (f) Using a center punch, punch the centers of the four (4) hole locations. (Fig. 3-2)
- (g) Remove the template. Make sure you can see all four (4) punch marks.

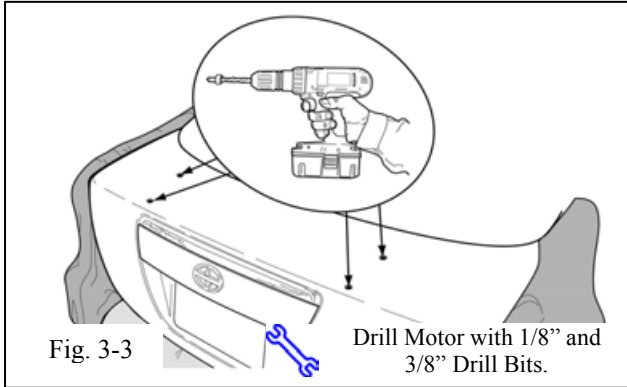

- (h) Using the 1/8" drill bit, drill a pilot hole at all four (4) locations. Enlarge all holes with the 3/8" drill bit. (Fig. 3-3)

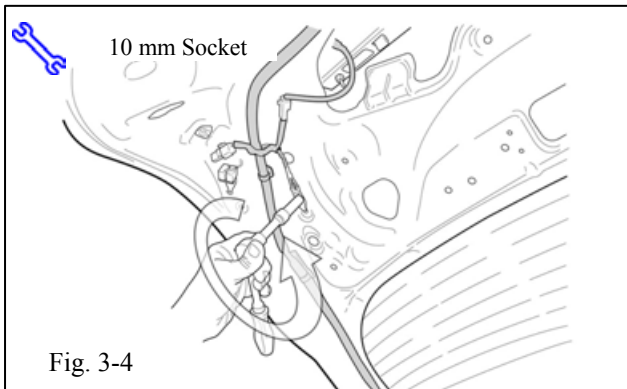

- (i) Open the lift gate and disconnect the electrical ground on the driver's side of the inner panel of the lift gate and tuck it out of the way as shown. (Figs. 3-4 & 3-5)

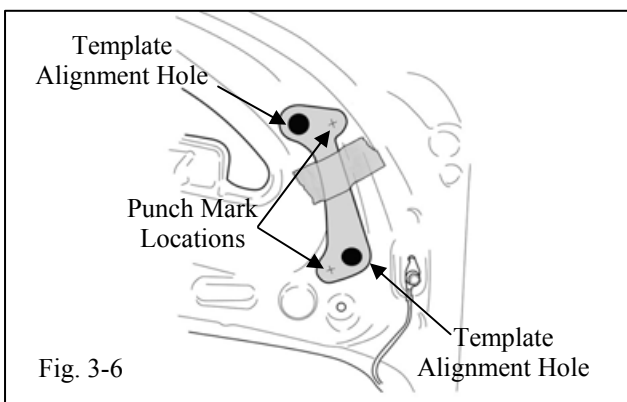
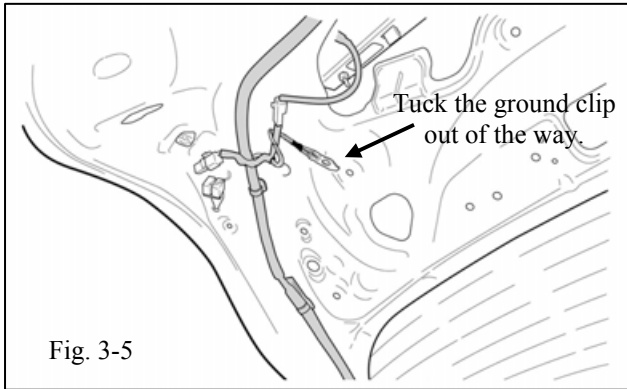

-  (j) Cut out the perimeter of the inner panel hole template and the two alignment holes. Place the template on the inner panel of the lift gate as shown on the passenger side. The alignment holes in the template will line up with existing holes in the inner panel. Center punch the two (2) punch mark locations. Turn the template over and repeat for the driver's side of the lift gate. (Fig. 3-6)

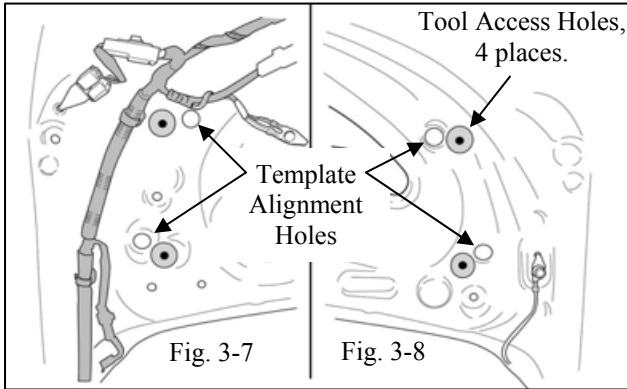

(k) Using the 3/4" hole cutter, drill the four (4) punch locations in the inner panel to make tool access holes. The 3/8" holes in the outer skin of the lift gate will be visible through these access holes. Use caution to avoid cutting the wire harness. Reconnect the wire harness ground and torque to 43 lbf-in (4.9 Nm) When complete, the new holes will look as shown. (Figs. 3-7 & 3-8)

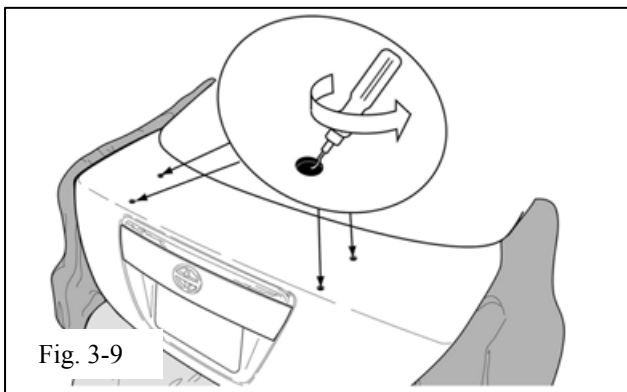

(l) Using a deburring tool, carefully deburr the eight (8) drilled holes. (Fig. 3-9)

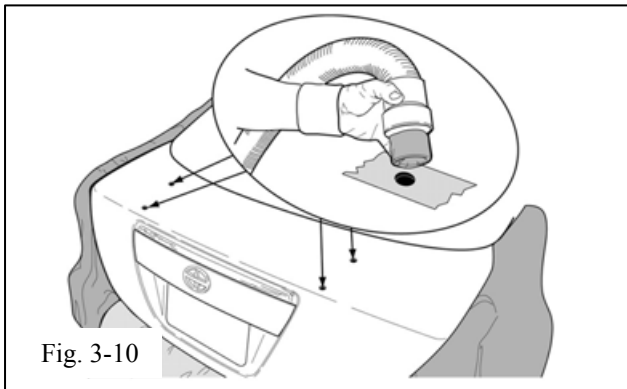

(m) Vacuum the surface of the trunk lid and the surrounding drilled areas. Remove masking tape. (Fig. 3-10)

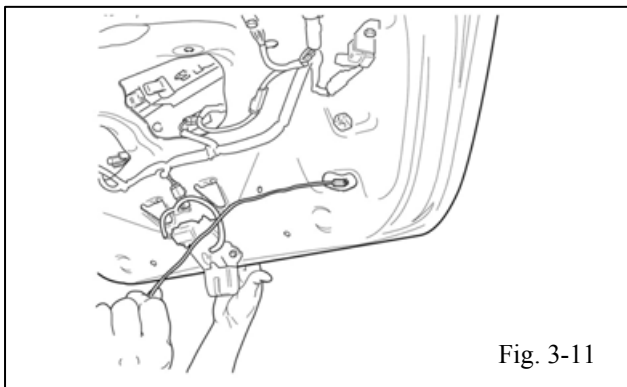

(n) Use a magnet with a flexible shaft to remove any remaining metal chips/discs from the drilling process. (Fig. 3-11)

4. Preparation for Spoiler Attachment.

(a) The trunk lid where the spoiler attaches must be cleaned with 3M Prep Solvent 70 and a lint free cloth.

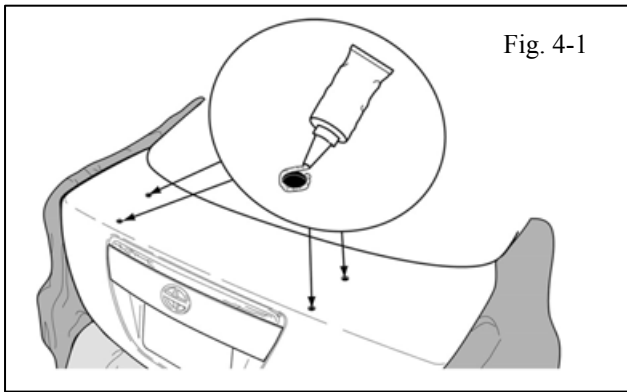

- (b) After cleaning, carefully apply 3M Ultra-Pro Body Sealant to all drilled hole edges. (Fig. 4-1)

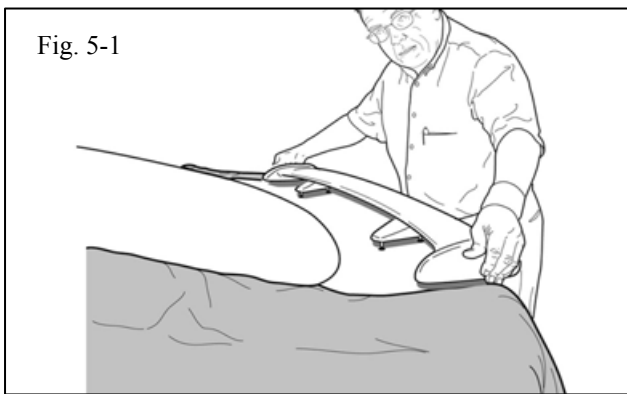

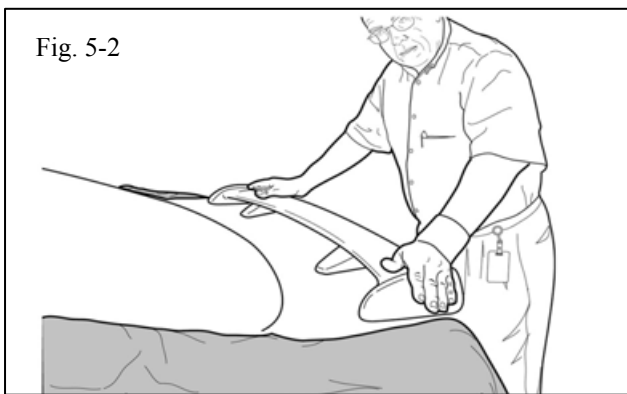

- (c) The trunk and spoiler should be a minimum of 60° F for proper set-up of adhesive tape. Use a hot air blower to heat the surface if the temperature is below 60° F. The adhesive tape on the spoiler must have full contact between spoiler and trunk lid for proper sealing to trunk lid.

5. Attaching the Spoiler to the Lift Gate.

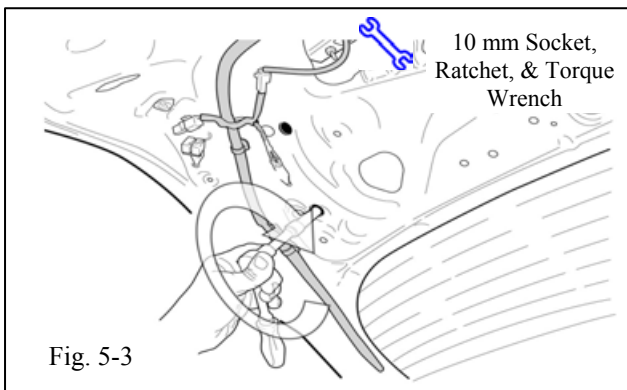

- (a) Remove the plastic liners from adhesive tape pads. Be careful not to touch or allow any contaminants to come into contact with adhesive pads.
- (b) Position the spoiler over the lift gate with the drill holes aligned to the spoiler studs. (Fig. 5-1)



- (c) Lower the spoiler down into place and press down to fully seat it. Continue to apply pressure to ensure complete adhesion of the spoiler to lift gate surface. (Fig. 5-2)
- (d)  Open the lift gate and install the four (4) flange nuts to the studs. Tighten the nuts to 43 lbf-in (4.9 Nm). (Fig. 5-3)

6. Reassemble the Vehicle.

- (a) Reinstall all removed panels and parts. Be sure that all the panel clips are engaged.



- (b) Check to be certain there are no metal chips in the vehicle trunk area and rear bumper.

7. Gas Lift Strut Disposal.



- (a) Due to high internal pressure, metal chips and oil can be ejected. Eye Protection (goggles and face shield) must be used when venting the Gas Lift Struts.

- (b) Without deforming the Gas Lift Strut, clamp it between two V-Blocks in such a way that the dimension X is at least 25 mm. (Fig. 7-1)



- (c) For venting, slowly drill or saw open the Gas Lift Strut at the two points shown. Drilling with a 1/8" diameter drill bit is the preferred method. (Fig. 7-1)

- (d) Drain the oil from the unpressurized Gas Lift Strut. Dispose of the oil in accordance with local waste disposal regulations.

- (e) The unpressurized Gas Lift Strut must be disposed of in accordance with local waste disposal regulations

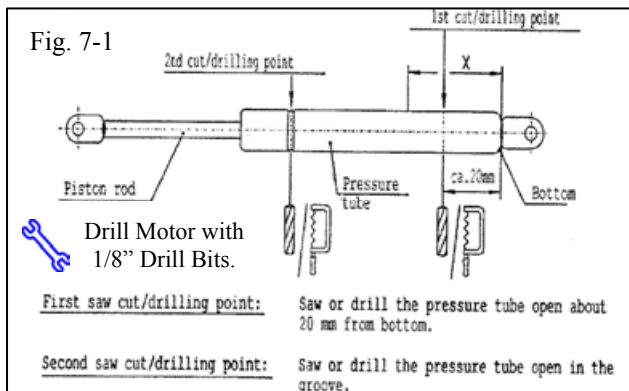

Checklist - these points **MUST** be checked to ensure a quality installation.

Check:

Look For:

Accessory Function Checks

Check for Spoiler Alignment.

Check for tape adhesion.

Verify gas strut operation.

The Spoiler should be centered from side to side and square to the rear window edge.

The Spoiler should have a uniform gap around the perimeter of the stanchion footprint. The maximum allowable gap is 1.7 mm.

The gas struts should hold the lift gate in the open position.