

Preparation

**Part Number: PT47A-02090-WH**

**NOTE:** Part number of this accessory may not be the same as the part number shown.

**Kit Contents**

Item #	Quantity Req.	Description
1	1	Corolla Spoiler Wire Harness
2		
3		

--	--

\*Mandatory

**Vehicle Service Parts** (may be required for reassembly)

Item #	Quantity Req.	Description
1		
2		
3		

**Hardware Bag Contents**

Item #	Quantity Req.	Description
1	6	Foam tape

**Additional Items Required For Installation**

Item #	Quantity Req.	Description
1	1	Rear Spoiler Installation Instructions(P/N PT47A-02090-XX
2		

**Legend**



**STOP:** Damage to the vehicle may occur. Do not proceed until process has been complied with.



**OPERATOR SAFETY:** Use caution to avoid risk of injury.



**CAUTION:** A process that must be carefully observed in order to reduce the risk of damage to the accessory/vehicle and to ensure a quality installation.



**TOOLS & EQUIPMENT:** Used in Figures calls out the specific tools and equipment recommended for this process.



**REVISION MARK:** This mark highlights a change in installation with respect to previous issue.

**Conflicts**

--	--

**Recommended Tools**

<b>Personal &amp; Vehicle Protection</b>	<b>Notes</b>
Safety Goggles	
Blankets, Small Parts Tray	
<b>Special Tools</b>	<b>Notes</b>
None	
<b>Installation Tools</b>	<b>Notes</b>
Trim Panel Clip Removal Tool	Panel Pry Tool #1 Toyota SST # 0002-06001-01
<b>Special Chemicals</b>	<b>Notes</b>

**General Applicability**

--	--

**Recommended Sequence of Application**

Item #	Accessory
1	
2	
3	

## Procedure

Care must be taken when installing this accessory to ensure damage does not occur to the vehicle. The installation of this accessory should follow approved guidelines to ensure a quality installation.

These guidelines can be found in the "Accessory Installation Practices" document.

This document covers such items as:-

- Vehicle Protection (use of covers and blankets, cleaning chemicals, etc.).
- Safety (eye protection, rechecking torque procedure, etc.).
- Vehicle Disassembly/Reassembly (panel removal, part storage, etc.).
- Electrical Component Disassembly/Reassembly (battery disconnection, connector removal, etc.).

Please see your Toyota dealer for a copy of this document.

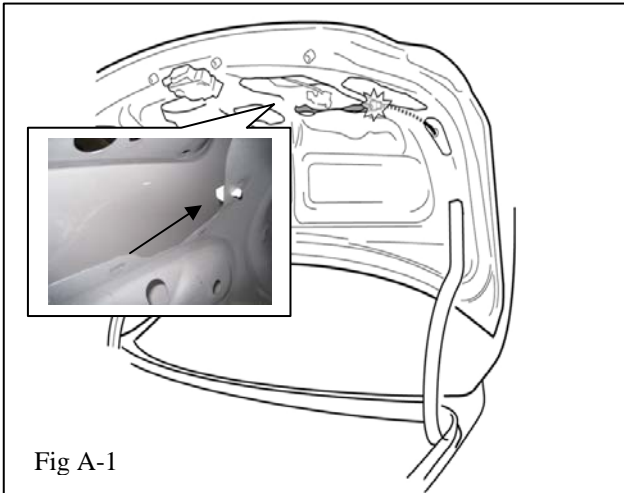

Fig A-1

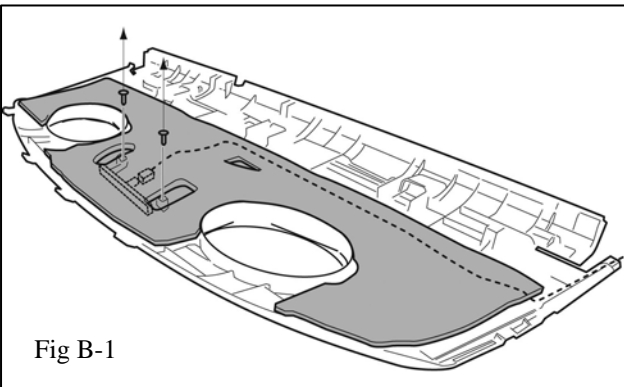

Fig B-1

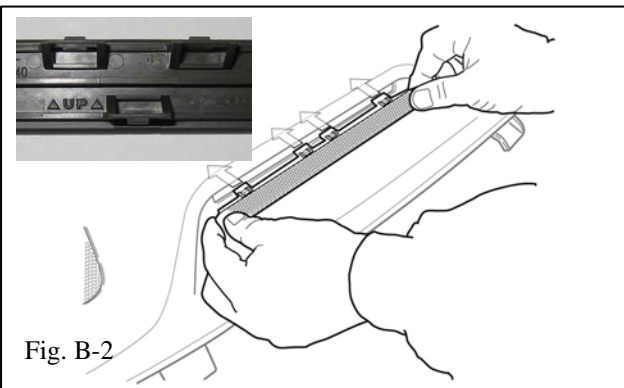

Fig. B-2

**NOTE:** This Installation Procedure references much of the Procedure given in Section II of Rear Spoiler Installation Instructions (P/N PT47A-02090-XX)

### 1. Checking for Factory Installed Harness



- (a) Complete steps A-1 through B-3 from the Rear Spoiler Installation Instructions Section II



- (b) If the connector plug shown is present, the vehicle is pre-wired for the Rear spoiler and it is not necessary to install this supplemental wiring harness. (Fig. A-1)

- (c) If the connector plug is not present, proceed as follows.

### 2. Trim Panel Removal

- (a) Complete Steps B-4 through B-9 for Rear Spoiler Installation Section II.

### 3. Replacing the CHMSL

- (a) Remove the CHMSL and wiring from it's mounting in the Package tray and slide it out from under the felt padding. Fig B-1
- (b) Discard the CHMSL and wiring.
- (c) From the outside of the package tray, install the CHMSL Block Out Plate in the location of the removed CHMSL. Check the up arrow on the back side. It points up when installed Fig B-2

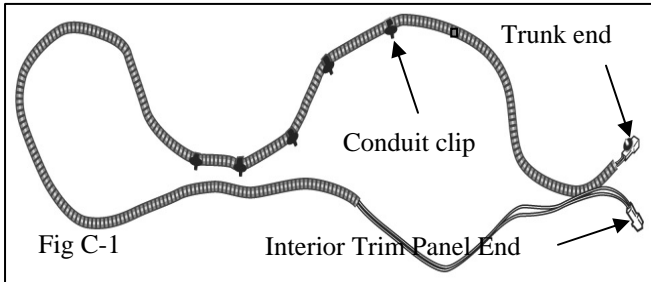

#### 4. Installation of the Spoiler Wire Harness

(a) Examine the wiring harness. The end nearest a Conduit Clip is the trunk lid end. This is the end you start threading through the vehicle from inside the passenger compartment. Fig C-1

(b) From within the rear passenger compartment on the LH side attach the Trim Panel Connector end to the vehicle side harness that once fed the CHMSL in the package tray. Wrap connector with Foam Tape Pad Fig C-2

(c) Feed the harness through the hole leading into the trunk. Fig C-2

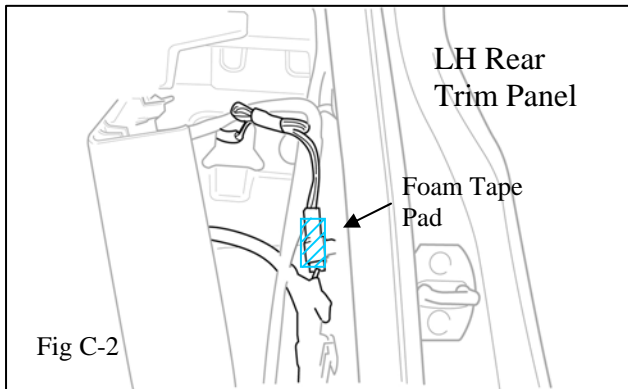

(d) From inside the trunk continue to lace the harness across to the right hand side of the vehicle. Fig C-3

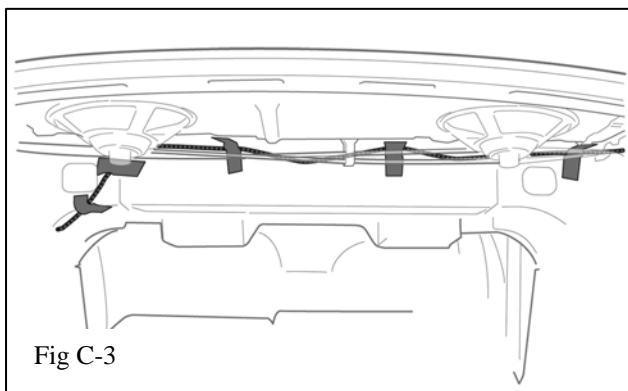

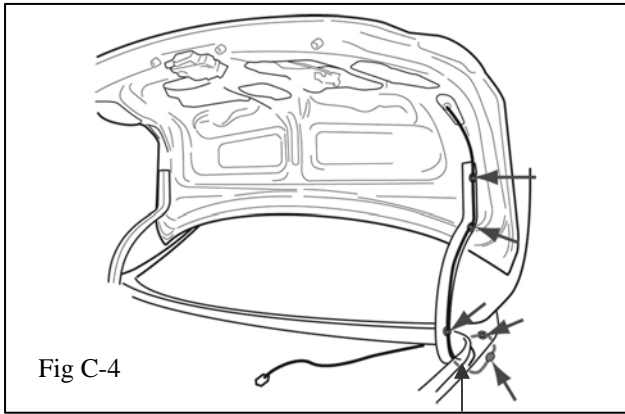

- (e) Bring the harness up along the outside of the right hand trunk lid support arm.
- (f) Thread the connector into the trunk lid as shown and clip the connector into the trunk lid sheet metal. Fig C-4 and Fig C-5
- (g) Starting at the top of the trunk lid arm mount the harness onto the trunk lid arm by pushing the conduit clip pins into the holes in the trunk lid arm. Fig C-4
- (h) Work you way down the arm. The last conduit clip mounts just beyond the end of the arm.
- (i) Fasten the harness across the back of the trunk using 5 Foam Tape Pads. Fig C-6

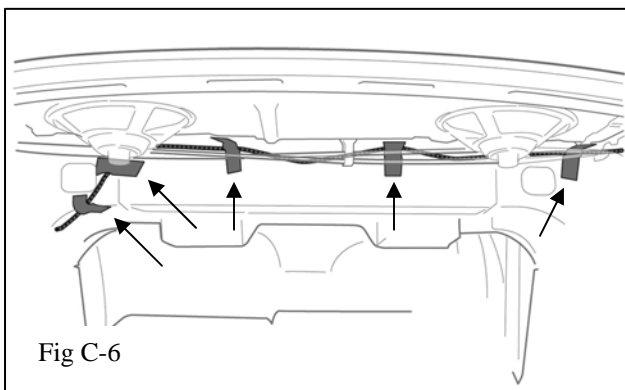
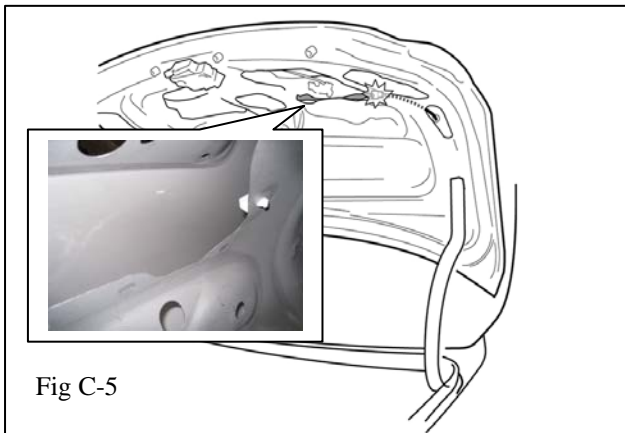

**5. Continuation of Rear Spoiler Installation**

- (a) Continue the normal Rear Spoiler Installation Procedure. ( See Section C Rear Spoiler Installation Instructions Section II)

**6. Perform Function Verification**

- (a) Complete the functional verification in the Rear Spoiler Installation Instructions

**7. Reassemble the Vehicle**

- (a) NOTE: at this point complete the “Reassemble the Vehicle” section in the Rear Spoiler Installation Instructions

**TOYOTA COROLLA 2009- REAR SPOILER WIRE HARNESS**  
Checklist - these points **MUST** be checked to ensure a quality installation.

<u>Check:</u>	<u>Look For:</u>
<p><u>Accessory Function Checks</u></p> <p><input type="checkbox"/></p> <p><input type="checkbox"/></p> <p><input type="checkbox"/></p> <p><input type="checkbox"/></p>	<p><input type="checkbox"/></p>
<p><u>Vehicle Function Checks</u></p> <p><input type="checkbox"/></p> <p><input type="checkbox"/></p>	<p>Complete Section III Functional Verifications in the Rear Spoiler Installation Instructions.</p>