

Part Number: PT413-34070

Kit Contents

Item #	Quantity Req.	Description
1	1	License Plate Bracket

Hardware Bag Contents

Item #	Quantity Req.	Description
1	2	M6 x 25 Philips pan-head self-tapping screw
2	2	M6 x 50 Philips pan-head self-tapping screw

Additional Items Required For Installation

Item #	Quantity Req.	Description
1	1	Vehicle front license plate

Conflicts

Note:

Recommended Tools

Safety Tools	
Safety glasses	
Special Tools	
Installation Tools	
#3 Philips Screwdriver	
1/8" or 3mm drill bit	
Electric Drill	
Special Chemicals	

Color Applicability/Trim Level

Color	Accessory																			

General Applicability





Toyota Tundra

Recommended Sequence of Application

Item #	Accessory	
1		
2		
3		

*Mandatory

Legend

	STOP: Damage to the vehicle may occur. Do not proceed until process has been complied with.
	OPERATOR SAFETY: Use caution to avoid risk of injury.
	CAUTION: A process that must be carefully observed in order to reduce the risk of damage to the accessory/vehicle and to ensure a quality installation.
	TOOLS & EQUIPMENT: Used in figures, calls out the specific tools and equipment recommended for this process.

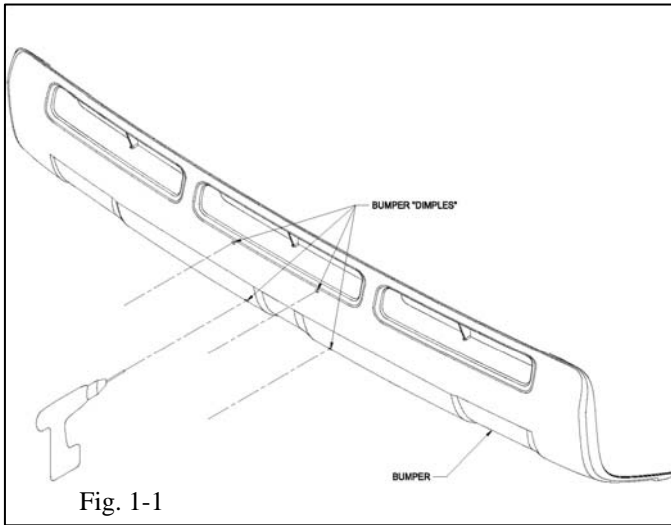

1. Bracket Installation.

(a) Remove front license plate or paper placeholder.

 (b) Pre-drill dimples in bumper with a 1/8" (3mm) diameter drill bit, to a depth of approximately 1/8" (Fig. 1-1)

(c) Install license plate in license plate bracket, then screw into bumper at dimples. Use 25mm long screws on top, and 50mm long screws on the bottom. (Fig. 1-2, next page)

 (d) Drive screw until secure; do not over-tighten.

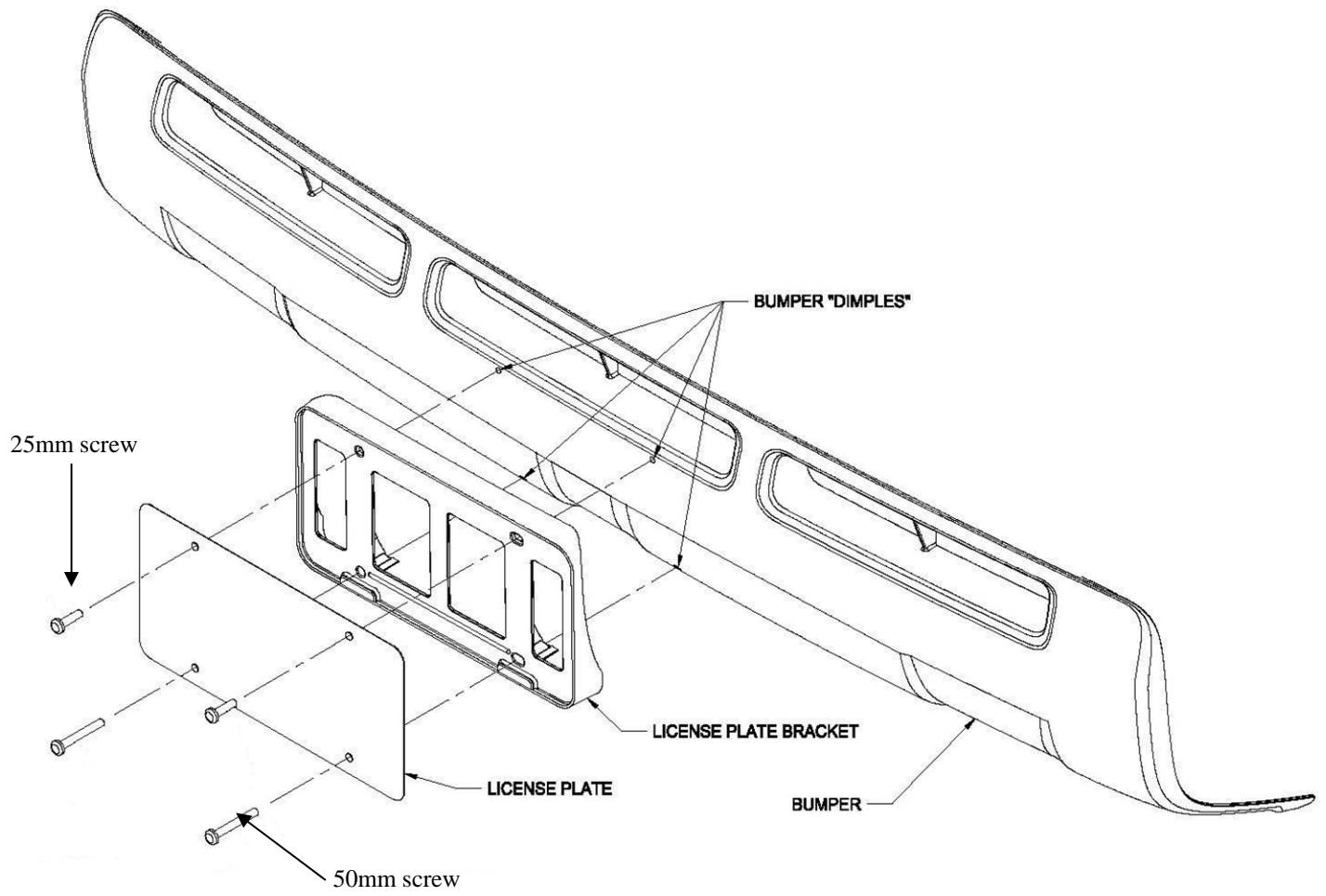

Fig. 1-2

TOYOTA TUNDRA 2007 - LICENSE PLATE BRACKET
Checklist - these points **MUST** be checked to ensure a quality installation.

Check: _____

- Repair or replace the parts if required
- Check gap of bracket to bumper

Look For: _____

Check bracket prior to installation.

Gap should be no more than 3 mm.

