

Preparation

Part Number:

- PT400 – 34070 (Ctr Asm, 4.7L, Short W/B)
- PT400 – 34071 (Ctr Asm, 5.7L, Short W/B)
- PT400 – 34072 (Ctr Asm, 4.7L, Mid-W/B)
- PT400 – 34074 (Ctr Asm, 5.7L, Mid-W/B)
- PT400 – 34073 (Tailpipes)

NOTE: Part number of this accessory may not be the same as the part number shown.

Kit Contents

Item #	Quantity Req'd.	Description
1	1	Center Muffler Assembly
2	2	Tail Pipe Assembly
3	1	Hardware Bag
4	1	Heat Shield

Hardware Bag Contents

Item #	Quantity Req'd.	Description
1	1	Bracket Sub-Assembly
2	1	Nut
3	2	Clamp
4	2	Gasket
5	1	Rubber Hanger
6	1	Rubber Hanger Boot

Additional Items Required For Installation

Item #	Quantity Req'd.	Description
1		

Conflicts

Vehicles equipped with long wheel base (crew cab w/ long bed), or V6 Engine

Recommended Tools

Personal & Vehicle Protection	Notes
None	
Special Tools	Notes
Rubber Hanger Removal Tool	Ex. Snap On P/N YA3202
Foam Block	2 pcs, 32 mm thick
Installation Tools	Notes
Ratchets	3/8 Drive
Sockets(3/8 Deep Drive)	10, 12, 14 (mm), 15 (mm)
3 inch Ratchet Extension	3/8 Drive
Torque Wrench	0-60 lbs-ft
Special Chemicals	Notes
Lubricant	Soap and Water, WD-40
Glass Cleaner	

General Applicability

Models with short or mid-wheel base, and 4.7L or 5.7L V8 Engine





Recommended Sequence of Application

Item #	Accessory
1	

Vehicle Service Parts (may be required for reassembly)

Item #	Quantity Req'd.	Description
1		

Legend

	STOP: Damage to the vehicle may occur. Do not proceed until process has been complied with.
	OPERATOR SAFETY: Use caution to avoid risk of injury.
	CAUTION: A process that must be carefully observed in order to reduce the risk of damage to the accessory/vehicle and to ensure a quality installation.
	TOOLS & EQUIPMENT: Used in Figures calls out the specific tools and equipment recommended for this process.

Care must be taken when installing this accessory to ensure damage does not occur to the vehicle. The installation of this accessory should follow approved guidelines to ensure a quality installation.

The guidelines can be found in the “Accessory Installation Practices” document.

This document covers such items as:

- Vehicle Protection (use of covers and blankets, cleaning chemicals, etc.)
- Safety (eye protection, rechecking torque procedure, etc.)
- Vehicle Disassembly/Reassembly (panel removal, part storage, etc.)
- Electrical Component Disassembly/Reassembly (battery disconnection, connector removal, etc.)

Please see your Toyota dealer for a copy of this document.

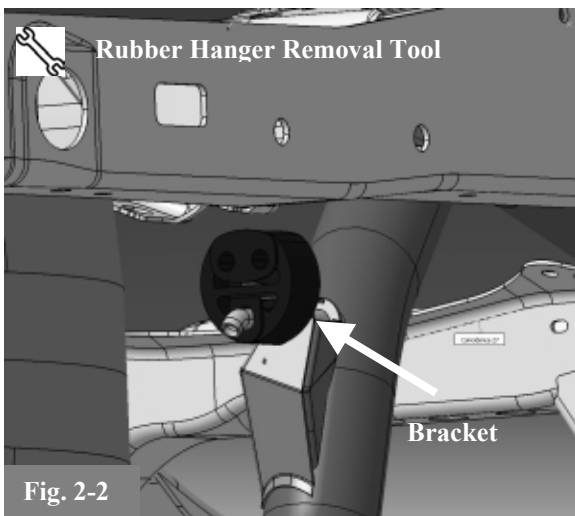
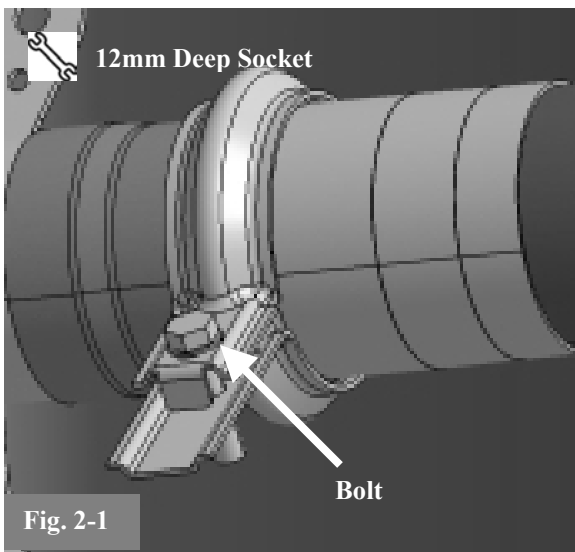

1. Check the Kit Contents.

-  (a) Make sure that the kit contains all the parts listed in the kit contents.

2. Remove Existing OE Tailpipe Assembly.

-  (a) Remove and discard V-Band clamp bolt and clamp located in the rear of the Original Equipment (OE) muffler (12mm Deep Socket). (Fig. 2-1)
- (b) Pry passenger's side tailpipe bracket loose from rubber hanger. (Fig. 2-2)

NOTE: Lubricating (ex. soap and water) the rubber exhaust hangers can facilitate the removal of rubber hangers.

- (c) Remove the OE tailpipe assembly from the vehicle.
- (d) Remove and discard the gasket from the OE muffler rear outlet where the clamp connected the tailpipe.
- (e) Leave the OE rubber hanger that held the OE tailpipe on the vehicle rod hanger.

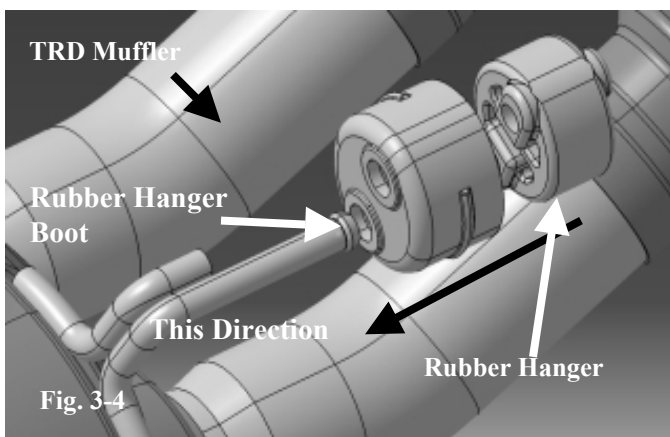
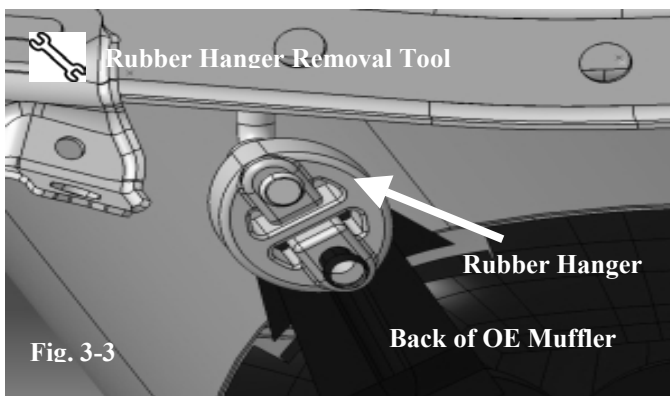
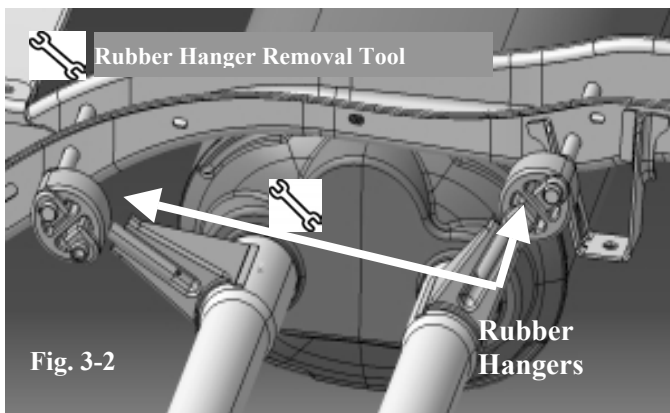
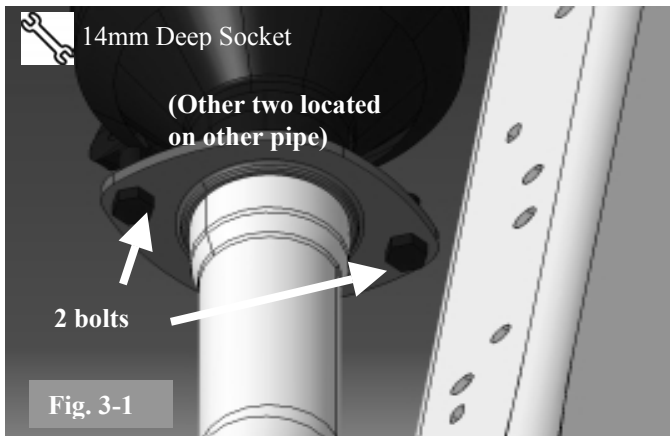

3. Remove Existing OE Center Muffler Assembly.

-  (a) Remove four (4) bolts from the two front flanges located between the catalytic converters and OE center muffler assembly front pipes. (14mm Deep Socket) (Fig. 3-1)

 **NOTE:** Keep all OE bolts and gaskets.

- (b) Pry both OE center muffler front assembly pipes loose from two (2) rubber hangers, located in front of muffler, and leave the rubber hangers in place. (Fig. 3-2)
- (c) Pry the rubber hanger located in the back of the muffler loose from the muffler's rear hanger rod. Also, remove the rubber hanger from the vehicle side hanger rod. (Fig. 3-3)
- (d) Remove the OE center muffler assembly.
- (e) Slip the rubber hanger boot, supplied in the kit, over the rubber hanger that was removed from the back of the OE muffler. Then pre-install the rubber hanger with boot on the hanger rod located on the rear side of the TRD center muffler assembly with the enclosed side of the boot facing toward the muffler. (Fig. 3-4)

 **CAUTION:** The rubber hanger boot must be installed with the enclosed side facing toward the muffler to ensure proper protection of rubber hanger from heat.

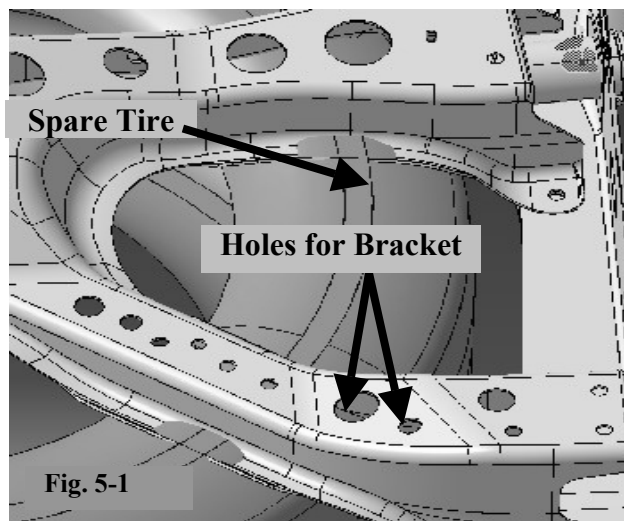
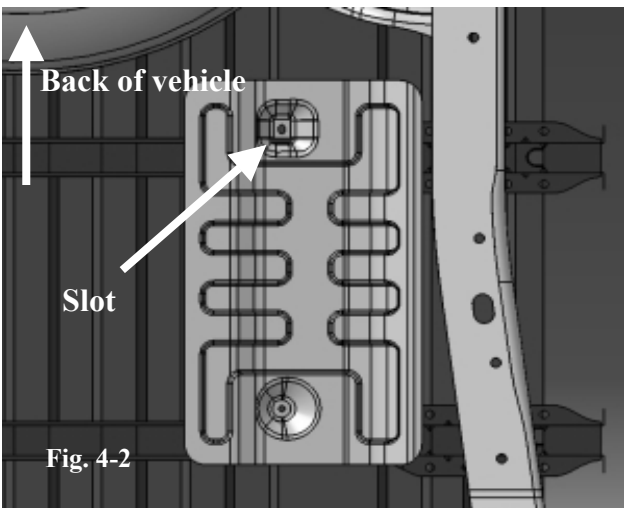
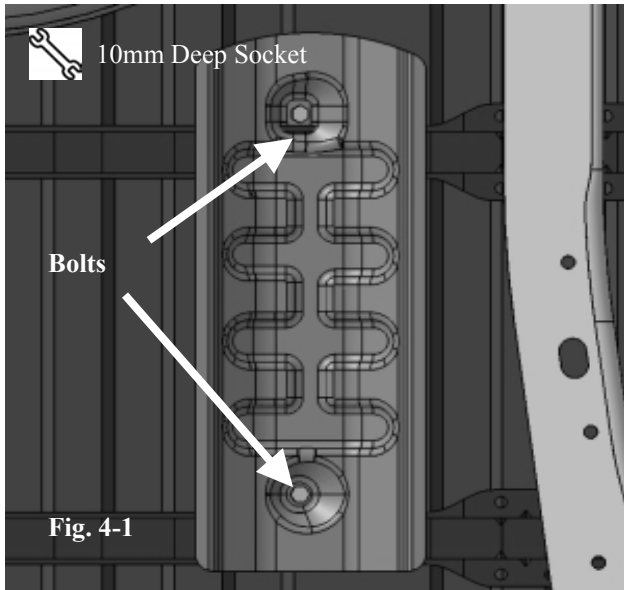

4. Remove and Install Heat Shield.

-  (a) Locate the body side heat shield on the rear deck above the original tailpipe. Remove the two bolts holding the body side heat shield to the rear deck. (10mm deep socket with extension) (Fig. 4-1)

 **NOTE:** Keep both OE bolts.

- (b) Remove OE heat shield and replace with TRD heat shield using OE bolts to secure.
Torque: 7lbs-ft (9.0 N-m)
Min. 4.0 lbs-ft (5.5 N-m),
Max. 9.0 lbs-ft (12.5 N-m)
- (c) Ensure the slotted hole on the TRD heat shield for the bolt is located towards the back of the vehicle. (Fig. 4-2)

5. Install Bracket for LH Tailpipe.

- (a) Locate the holes on the front driver side channel of the spare tire carrier as shown. (Fig. 5-1)

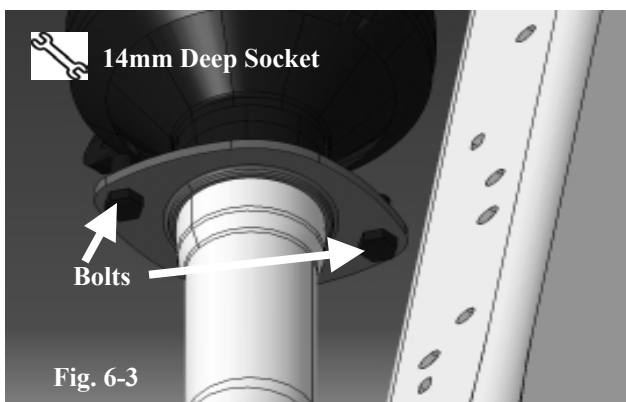
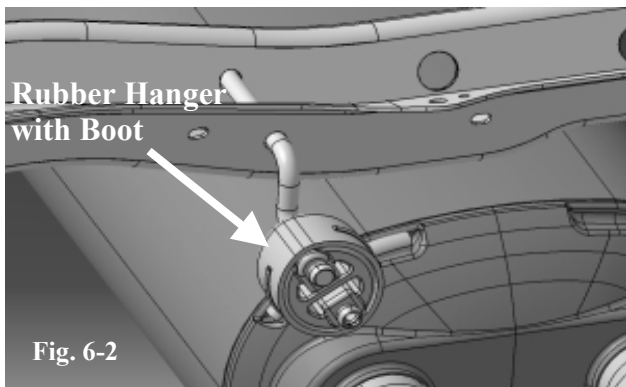
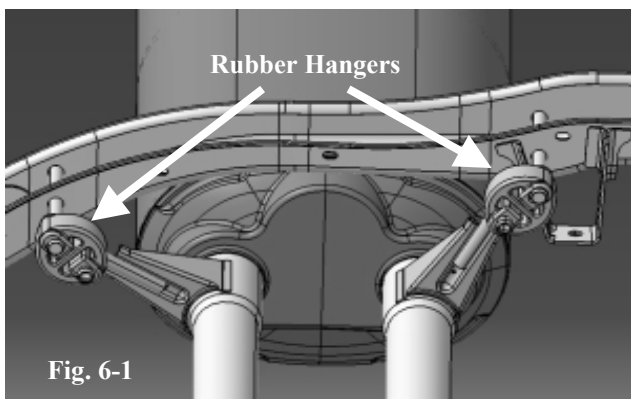
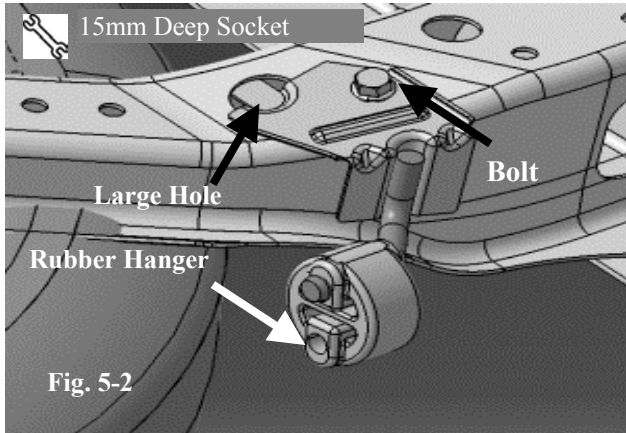



- (b) Line up the anti-rotation tab of the bracket with the larger hole and insert the bolt into smaller hole. (Fig. 5-2)
- (c) Install the nut, supplied in the kit, on the bolt of the bracket to secure the bracket to the spare tire carrier. Make sure the hole and bolt are centered. Then tighten the nut to 35 ± 5 lbs-ft (48 ± 6 N-m) of torque. (15mm deep socket) (Fig. 5-2)
- (d) Install the new rubber hanger, supplied in the kit, on the hanger rod. (Fig. 5-2)

 **NOTE:** Access to the nut to secure the bracket is from underneath the spare tire carrier.

6. Install new TRD Center Muffler Assembly.

- (a) Attach the two hanger brackets of the TRD center muffler assembly front pipes to the existing rubber hangers and rods on the vehicle frame. (Fig. 6-1)
- (b) Attach the rubber hanger with boot previously installed in the rear of the TRD center muffler assembly to the vehicle side hanger on the vehicle frame. (Fig. 6-2)

 (c) Verify the OE gaskets at the two front flanges, located between the catalytic converters and muffler front pipes, are in place before reconnecting the pipes.

 (d) Align the TRD center muffler assembly front pipes with the catalytic converters' rear pipes. Then reinstall the OE bolts on both flanges evenly, ensuring proper flange alignment. (Fig. 6-3)

 **NOTE:** Verify the gap between flanges is even on both sides of the bolts.

 (e) Tighten the OE bolts to 35 ± 5 lbs-ft (48 ± 6 N-m) of torque. (14mm deep socket) (Fig. 6-3)

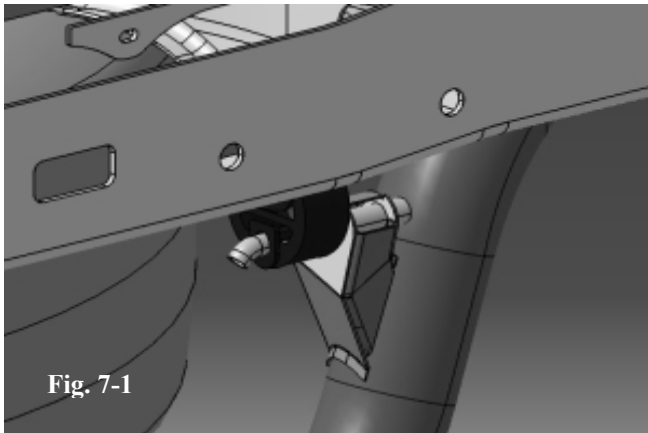

Fig. 7-1

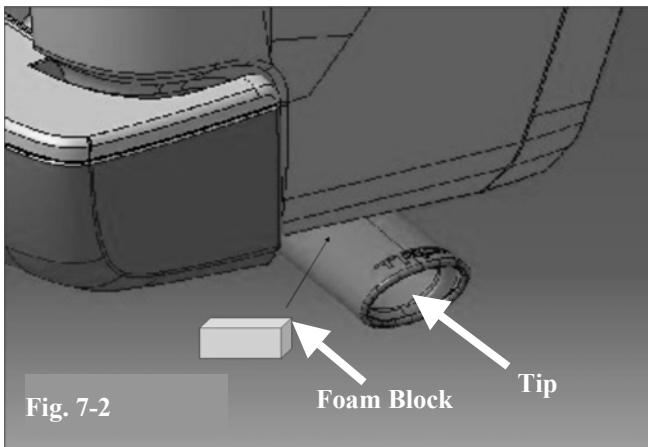

Fig. 7-2

Foam Block

Tip

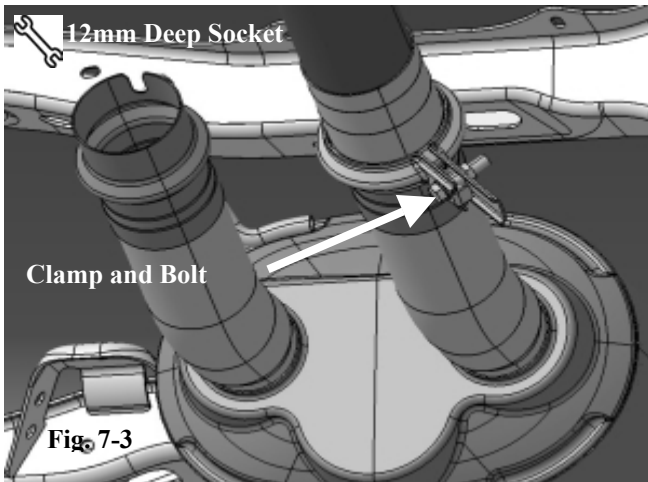

Fig. 7-3

12mm Deep Socket

Clamp and Bolt

- (f) Install the two new gaskets, supplied in the kit, on the TRD center muffler assembly rear (outlet) pipes for tailpipe installation.

7. Install new TRD RH Tailpipe

- (a) Attach hanger rod of the TRD RH tailpipe assembly to the rubber hanger on the vehicle frame. (Fig. 7-1)



NOTE: Verify the gaskets have been installed on the outlet pipes of the TRD center muffler assembly.

- (b) Insert a foam block to set a gap of 32 mm between the exhaust tip and the rear side panel (Fig. 7-2).

- (c) Align the RH tailpipe with the RH outlet pipe on the muffler and insert until both flares are seated. Confirm the clearance between the side panel of the body and exhaust tip does not exceed 36 mm MAX.



- (d) Place clamp around flare and tighten bolt to 24±5 lb-ft (32±6 N-m) of torque. (Fig. 7-3) (12mm socket)



NOTE: Be sure to keep clamp handle orientation as shown in Fig. 7-3.

- (e) Remove exhaust tip protection wrap and clean tip with glass cleaner and non-scratching cloth if necessary.

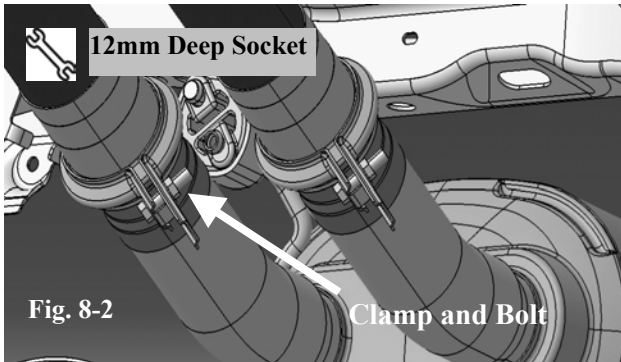
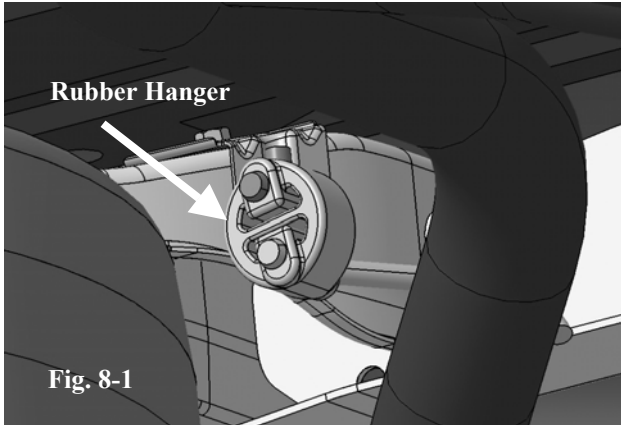

8. Install new TRD LH Tailpipe

- (a) Attach hanger rod of the TRD LH tailpipe assembly to the rubber hanger on the vehicle frame. (Fig. 8-1)



NOTE: Verify the gaskets have been installed on the outlet pipes on the TRD center muffler assembly.

- (b) Insert a foam block to set a gap of 32 mm between the exhaust tip and the rear side panel (see Fig. 7-2 on previous page).

- (c) Align the LH tailpipe with the LH outlet pipe on the muffler and insert until both flares are seated. Confirm the clearance between the side panel of the body and exhaust tip does not exceed 36mm MAX.



- (d) Place clamp around flare and tighten bolt to 24±5 lb-ft (32±6 N-m) of torque. (Fig. 8-2)



NOTE: Be sure to keep clamp handle orientation as shown in Fig. 8-2.

- (e) Remove exhaust tip protection wrap and clean tip with glass cleaner and non-scratching cloth if necessary.

TOYOTA TUNDRA TRD 2007 - DUAL EXHAUST SYSTEM

Checklist – these points **MUST** be checked to ensure a quality installation.

Check:

Look for: _____



Accessory Function Checks

- Correct part has been installed.
- All joints have been securely fastened.
- Hooks/hangers have been securely reattached.
- Start the vehicle.

- Verify part number on package.
- Verify joints are tightened.
- Verify hooks/hangers are securely attached.

- Verify the pipe flange and clamp joints do not have abnormal leak sound or water leak.

Vehicle Function Checks

-  Inspection torque – muffler to converter assembly.
-  Inspection torque – tailpipe assembly to muffler outlet connection.

- 35 ± 5 lb-ft (48 ± 6 N-m) of torque

- 24 ± 5 lb-ft (32 ± 6 N-m) of torque