

**Part #: PT398-48170**

**Conflict**

Do not install into Vehicles without Factory Alarm.

**Recommended Sequence of Application**

Item#	Quantity	Description
1	1	V4 RES
2	1	V2 GBS

**Kit Contents**

Item#	Quantity	Description
1	1	V2 Wire Harness
2	1	GBS ECU Mounting Bracket

**Hardware Bag Contents**

Item#	Quantity	Description
1	1	GBS ECU 08190-0C820
2	1	GBS ECU Bracket
3	15	Wire Tie
4	1	Foam Tape
5	1	GBS Microphone 08192-6C810
6	2	V2 Window Label English 08192-009A0
7	2	V2 Window Label Spanish PT398-42091
8	1	V2 Owner's Guide

**Additional Items Required For Installation**

Item#	Quantity	Description

**Recommended Tools**

Personal & Vehicle Protection	Description
Safety Glasses	
Safety Gloves	(Optional)
Blankets, Parts Boxes	Blankets, Parts Boxes
<b>Special Tools</b>	
Striker Tool	CAD-E IADS P/N ALL 02-016-01
<b>Installation Tools</b>	
Screwdriver	#2 Phillips
Nylon Panel Removal Tool	e.g. Panel Pry Tool #1 Toyota SST# 00002-06001-01
Side Cutters	
Socket	10mm, extension
Torque Wrench	Battery: 48 in•lbf (5.4 N•m), ECU: 71 in•lbf (8 N•m)
Tape	Clear
<b>Special Chemicals</b>	
Cleaner	VDC Approved Cleaner
Glass Cleaner	Household Glass Cleaner

**Legend**

 **STOP:** Damage to the vehicle may occur. Do not proceed until process has been complied with.

 **OPERATOR SAFETY:** Use caution to avoid risk of injury.

 **CAUTION:** : A process that must be carefully observed in order to reduce the risk of damage to the accessory/vehicle and to ensure a quality installation.

 **TOOLS AND EQUIPMENT:** Used in Figures calls out the specific tools and equipment recommended for this process.

 **REVISION MARK:** This mark highlights a change in installation with respect to previous issue.

 **SAFETY TORQUE:** This mark indicates that torque is related to safety.

 **WIRE TIE LOCATION:** Wire Tie location number.

 **PREVIOUS WIRE TIE LOCATION:** This mark indicates a previously installed Wire Tie.

**Accessory Installation Practice (read before installation)**

Care must be taken when installing this accessory to ensure damage does not occur to the vehicle. The installation of this accessory should follow approved guidelines to ensure a quality installation. These guidelines can be found in the “Accessory Installation Practices” document.

This document covers such items as:

- Vehicle Protection (use of covers and blankets, cleaning chemicals, etc.)
- Safety (eye protection, checking torque procedure, etc.)
- Vehicle Disassembly/Reassembly (panel removal, part storage, etc.)
- Electrical Component Disassembly/Reassembly (battery disconnection, connector removal, etc.)

Please see your Toyota dealer for a copy of this document.

**Table of Contents**

---

- I. Preparation ..... 1–3
  - 1. Table of Contents ..... 2
  - 2. Wire Routing Overview ..... 3
- II. Procedure ..... 4–19
  - 1. Vehicle Disassembly ..... 4
  - 2. V2 ECU Installation ..... 7
  - 3. V2 Harness Installation ..... 8
  - 4. Microphone Installation ..... 15
  - 5. Complete the Installation ..... 17
- III. Checklist ..... 19-21
  - 1. Accessory Function Checks ..... 19
  - 2. Vehicle Appearance Check ..... 19
  - 3. Vehicle Function Checks ..... 20





d. Remove the Passenger's Side Step Cover.

e. Remove the Passenger's Cowl Cover.  
• Remove 1 Nut.

f. Remove the Passenger's Side Dash Cover.



g. Remove the Glove Box Under Cover.

h. Remove 2 Bolts from the bottom of the Glove Box.

i. Open the Glove Box.

j. Dislodge the Glove Box.

- Remove 3 Screws.

- k. Disconnect the Vehicle's Connector.
- l. Remove the Vehicle clamp from the Glove Box
- m. Remove the Glove Box.

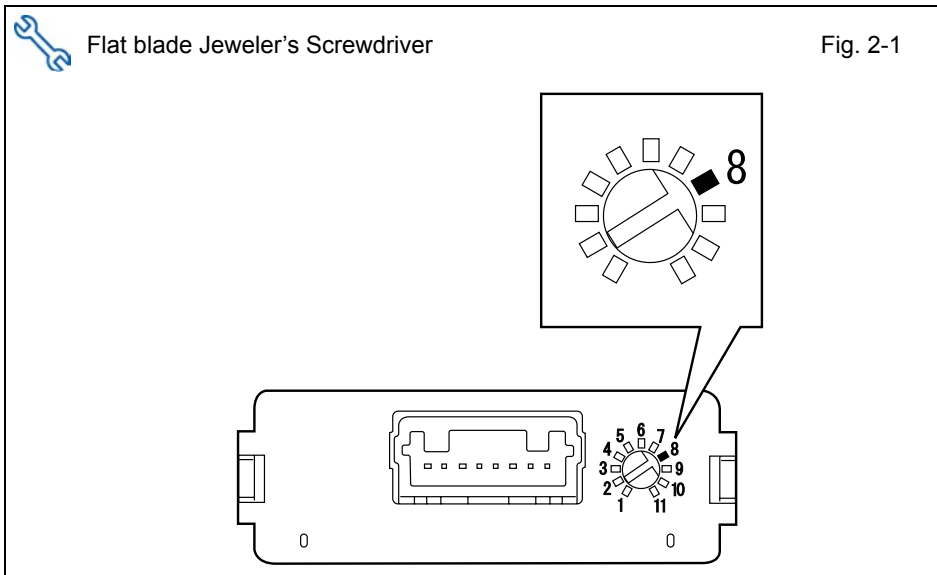

## 2. V2 ECU Preparation.

- a. Set the GBS Sensitivity Value to "8."

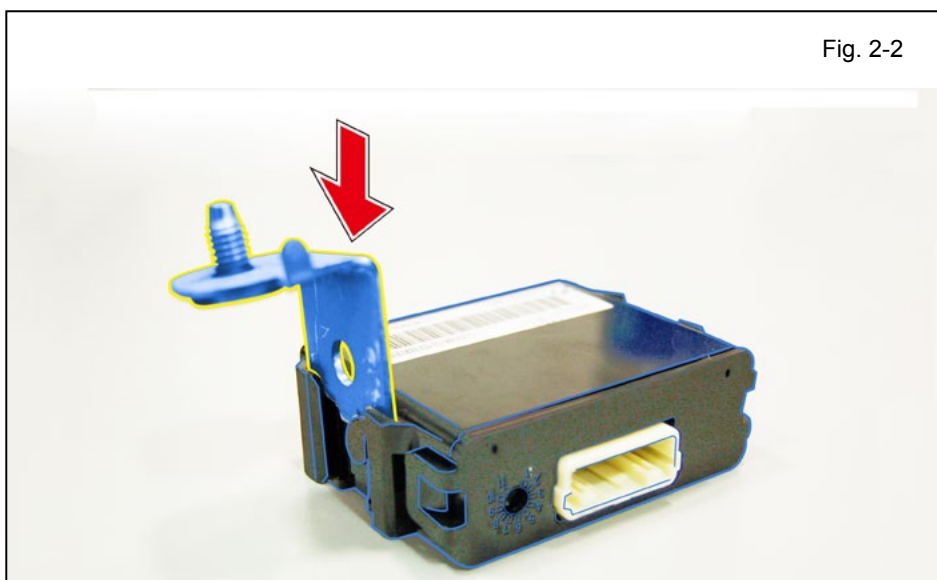

- b. Attach the GBS ECU Bracket to the GBS ECU.

### 3. V2 Harness and GBS ECU Installation.

- a. Route the V2 Harness 8P Connector behind the Vehicle Brace.

- b. Install the GBS ECU and the V2 Ground Wire Terminal using the supplied Nut.

**Torque:** Tighten the Nut to 8 N•m (71 in•lbf).



**NOTE:** Make sure the Guide Pin is seated correctly.

- c. Plug in the V2 White 8P Connector to the GBS ECU.
- d. Secure the V2 Harness White Tape Marker to the Vehicle IP Reinforcement using 1 Wire Tie (#1). (Fig. 3-3)



**NOTE:** Make sure that the V2 Harness is routed behind the Vehicle Brace.



- e. Secure the V2 Harness to the Vehicle IP Reinforcement with 1 Wire Tie (#2). (Fig. 3-4)
- f. Secure the V2 Harness to the Vehicle Brace with 1 Wire Tie (#3). (Fig. 3-4)

- g. Secure the V2 Harness to the Vehicle Harness using 1 Wire Tie (#4). (Fig. 3-5)

- h. Secure the V2 Harness to the Vehicle Harness using 2 Wire Ties (#5, #6). (Fig. 3-6)

**V2 ONLY**



**NOTE:** If V4 (RES) is installed in the vehicle, skip to page 12 for V2/V4 Add-On (steps t-ag).

- i. Route the V2 Harness toward the Passenger side Cowl area.
- j. Secure the V2 Harness to the Vehicle Harness using 1 Wire Tie (#7). (Fig. 3-7)

- k. Remove the Tape securing the Vehicle 8P Pre-Connector.

- l. Connect the Vehicle White 8P Pre-Connector to the V2 White 8P Connector.

**V2 ONLY**

- m. Secure the V2 Harness to the Vehicle Harness using 1 Wire Tie (#8). (Fig. 3-10)
- n. Secure the V2 8P Connector to the Vehicle Harness using 1 Wire Tie (#9). (Fig. 3-10)



**NOTE:** Rotate the ratchet end on Wire Ties (#8, #9) toward the rear of the Vehicle.



**NOTE:** Place the 8P Connectors in reference to the illustration.

- o. Disconnect the Vehicle's Gray 18P Connector from the Connector Block.

- p. Connect the Vehicle's Gray 18P Connector to the V2 18P Connector.

**V2 ONLY**

q. Plug in the V2 Gray 18P Connector to the Vehicle Connector Block.

r. Secure the V2 Harness to the Vehicle Harness using 1 Wire Tie (#10). (Fig. 3-14)

s. Secure the 18P Connectors to the Vehicle Harness with 1 Wire Tie (#11). (Fig. 3-14)



**NOTE:** Rotate the ratchet end on Wire Ties (#10, #11) toward the rear of the Vehicle.



**CAUTION:** Do not secure to the AirBag Harness.



**NOTE:** Place the 18P Connector in reference to the illustration.



**NOTE:** Skip to Section 4 (p. 16) for Microphone Installation.

**V2/V4 Add-on ONLY**

t. Route the V2 Harness toward the Passenger side Cowl area.

u. Secure the V2 Harness to the Vehicle Harness using 1 Wire Tie (#7). (Fig. 3-15)

v. Secure the V4 8P Connector to the Vehicle Harness with 1 Wire Tie (#8). (Fig. 3-15)



**NOTE:** Rotate the ratchet end on Wire Ties (#7, #8) toward the rear of the Vehicle.

**V2/V4 Add-on ONLY**

w. Remove the Tape securing the V4 Harness 8P Connector.

x. Connect the V4 Harness 8P Connector to the V2 White 8P Connector.

y. Secure the V4 Harness to the Vehicle Harness using 1 Wire Tie (#9). (Fig. 3-18)

z. Secure the V2 8P Connector to the Vehicle Harness using 1 Wire Tie (#10). (Fig. 3-18)



**CAUTION:** Reduce stress on Wire Tie (#10) and the 8P Connector's wire as shown.



**NOTE:** Rotate the ratchet end on Wire Ties (#9, #10) toward the rear of the Vehicle.



**NOTE:** Place the 8P Connectors in reference to the illustration.

**V2/V4 Add-on ONLY**

aa. Cut the Wire Tie securing the V4 18P Connector.

ab. Disconnect the Vehicle's 18P Gray Connector from the V4 18P Connector.

ac. Connect the V2 Gray 18P Connector to the V4 Gray 18P Connector.

ad. Connect the Vehicle's Gray 18P Connector to the V2 Gray 18P Connector.

- ae. Secure the V2 Harness to the Vehicle Harness using 1 Wire Tie (#11). (Fig. 3-22)
- af. Secure the V4 & V2 Harness to the Vehicle Harness using 1 Wire Tie (#12). (Fig. 3-22)



**CAUTION:** Do not secure to the Airbag Harness.

- ag. Secure the V4 18P Connector to the V2 18P Connector and Vehicle Harness using 1 Wire Tie (#13). (Fig. 3-22)



**NOTE:** Rotate the ratchet end on Wire Ties (#11, #12, #13) away from the surrounding Vehicle Harness and toward the rear of the Vehicle.

**4. Microphone Installation.**

- a. Partially reassemble the Vehicle.



**VERIFY:** That all Connectors are plugged in.



**VERIFY:** That Panels fit together properly, with no uneven gaps.

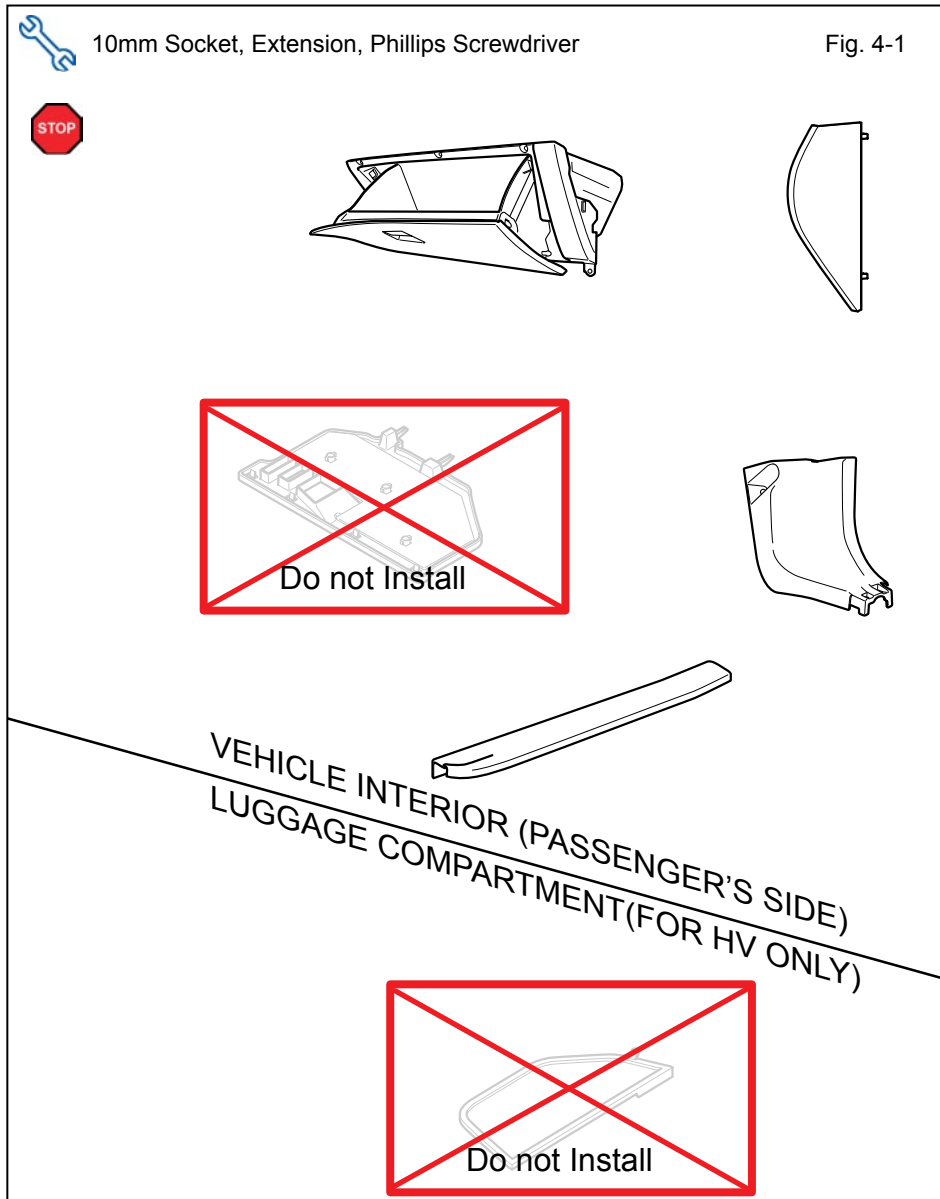

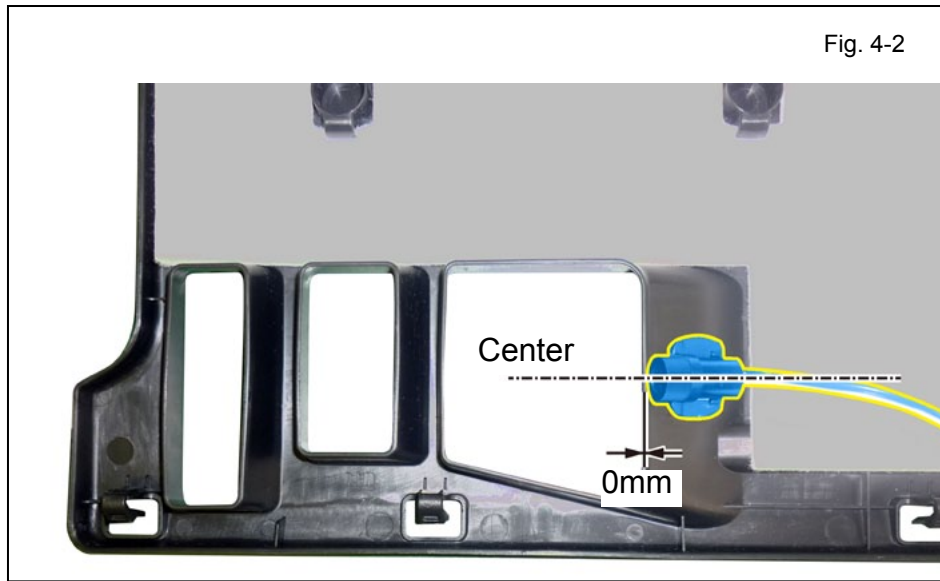

- b. Using the VDC approved cleaner and Cleaning Method, clean the area indicated on the backside of the Glove Box Under Cover.
- c. Attach the GBS Microphone to the backside of the Glove Box Under Cover as shown.



**NOTE:** Make sure to align GBS Microphone to the edge of the Glove Box Under Cover opening.

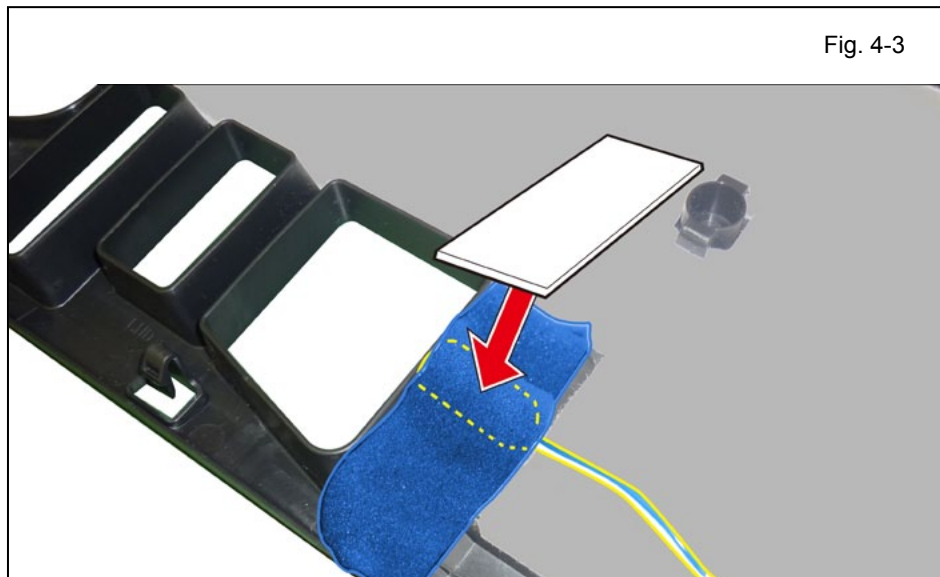

- d. Apply 1 Foam Tape to the GBS Microphone as shown.



**NOTE:** Make sure not to cover the Microphone's opening with the Foam Tape.

- e. Connect the V2 White 2P Connector to the GBS Microphone's Connector.



- f. Reinstall the Glove Box Under Cover.

## 5. Complete the Installation.

- For US Vehicles use the English Labels and discard the Spanish Labels.
- For Mexico Vehicles use the Spanish Labels and discard the English Labels.
  - a. Use Household Glass Cleaner to clean the inside of the Front Door Window.
  - b. Use Clear Tape to lift the Label off its protective backing.



**CAUTION:** Do not touch the adhesive surface.

- c. Attach the Label as shown.



**NOTE:** Make sure to Align the Label according to Etching or Other Label.

**REPEAT:** Steps 5a-5c on the other Front Door Window.

- d. Verify that the Short Pin is Installed.
  - If not, install now.

- For Hybrid Vehicles the battery is in the Luggage Compartment.
- For Gas Vehicles the battery is in the Engine Compartment.
- e. Position the Negative Battery Cable at the original factory position.



**Torque:** Tighten the Nut to 48 in•lbf (5.4 N•m).



**CAUTION:** Do not touch the Positive Terminal.

- f. Clean up and Remove trash.
- g. Sealed in its protective bag, place the Owner's Manual in the Glove Box.

**Accessory Function Checks**

Roll up all windows, and exit the vehicle with the remote.



**Vehicles w/Smart Key:** Take out the Smart Key from the Vehicle. Place them 15 ft. (4.5 meters) or more away from the Vehicle.

Perform		Look For
1	Lock the doors to start the system’s arming process.	The turn signal lights flash once. All doors lock. The Security LED lights up.
2	Wait 30 seconds.	Security LED starts flashing; the system is now armed.

Perform the following check in a temperature controlled environment (50°- 90°F)

3	With the tip of a key, or Striker Tool pulled all the way out (PPO only), tap the center of the driver’s door windows to trigger the alarm.	The horn sounds repeatedly. The headlights flash repeatedly. The turn signal lights flash repeatedly. The Security LED lights up.
4	Insert the key into the driver’s door key cylinder and turn it toward the back of the vehicle to stop the alarm.	The horn stops sounding. All the lights stop flashing and/ or turn off. The Security LED lights up.



**Vehicles w/Smart Key:** If the alarm does not trigger during functional verifications the Smart Key might be too close. Move them farther from the vehicle and test the system again.

**NOTE:** If the alarm still does not trigger during the section test, increase the GBS sensitivity to the next setting and test again.

**NOTE:** If you do not disarm the system, the alarm will last 20 seconds. It is not necessary to check the alarm duration.

**Vehicle Appearance Check**

Perform		Look For
<input type="checkbox"/>	After accessory installation and removal of protective cover(s), perform a visual inspection of the vehicle.	Ensure no damage (including scuffs and scratches) was caused during the installation process.  (For PPO installations, refer to TMS Accessory Quality Shipping Standard.)











**Vehicle Function Checks**

Function	Function
----------	----------

**Enter the Vehicle**

<input type="checkbox"/> Dome/Courtesy Lights	<input type="checkbox"/> Horn
---	-------------------------------

**Start the Vehicle**

<input type="checkbox"/> Panel/Switch Illumination	<input type="checkbox"/> Gauges
<input type="checkbox"/> Check Engine Light <i>If the warning light remains on, it may indicate a system malfunction.</i> 	<input type="checkbox"/> ABS Light (if equipped) <i>If the warning light remains on, it may indicate a system malfunction.</i> 
<input type="checkbox"/> Lamp Failure Sensor <i>If the warning light remains on, it may indicate a system malfunction.</i> 	<input type="checkbox"/> Track/Skid Control Light (if equipped) <i>If the warning light remains on, it may indicate a system malfunction.</i> 
<input type="checkbox"/> Seat Belt Warning Light <i>If the warning light remains on, it may indicate a system malfunction.</i> 	<input type="checkbox"/> Tire Pressure Monitoring System (TPMS).  <i>Prior to TPMS activation and Pre-delivery Service (PDS) of the Vehicle the TPMS light will blink when IG is turned on.</i>  <i>After TPMS activation and PDS of the Vehicle the TPMS light will illuminate for a few seconds and go off when IG is turned on.</i> 
<input type="checkbox"/> Air Bag Warning Light <i>If the warning light remains on, it may indicate a system malfunction.</i> 	
<input type="checkbox"/> Cruise Control Light (if equipped) 	

**Using a Mirror or Assistant check the following.**

<input type="checkbox"/> Trunk/Tailgate/Bed Lights (if equipped)	<input type="checkbox"/> Tail Lights
<input type="checkbox"/> Brake Lights	<input type="checkbox"/> Daytime Running Lights (if equipped)
<input type="checkbox"/> Backup Lights	<input type="checkbox"/> Marker Lights
<input type="checkbox"/> Clearance Sonar (if equipped)	<input type="checkbox"/> Power Back Door/Hatch (if equipped)

**Stop the Engine, Place the Vehicle's IG in the ON position.**

<input type="checkbox"/> Hazard Lights	<input type="checkbox"/> Turn Signal Lights
<input type="checkbox"/> Head Light	<input type="checkbox"/> Fog Lights (if equipped)
<input type="checkbox"/> High Beams	<input type="checkbox"/> Accessory Controls/Illumination (if equipped)
<input type="checkbox"/> Power Side Mirrors (if equipped)	<input type="checkbox"/> Convenience Memory Settings (if equipped)
<input type="checkbox"/> Power Sliding Door (if equipped)	<input type="checkbox"/> Rear Sunshade (if equipped)

Function		Function	
<input type="checkbox"/>	Front Wiper/Washer	<input type="checkbox"/>	Rear Wiper/Washer (if equipped)
<input type="checkbox"/>	Power Sun/Moon Roof (if equipped)	<input type="checkbox"/>	Rollover Side Curtain Air Bag Switch (RSCA) (if equipped)
<input type="checkbox"/>	Clock (if equipped)	<input type="checkbox"/>	Navigation System (if equipped)
<input type="checkbox"/>	Audio/Video (if equipped)	<input type="checkbox"/>	HVAC
<input type="checkbox"/>	Steering Wheel Audio Control (if equipped)	<input type="checkbox"/>	Rear Window Defogger (if equipped)
<input type="checkbox"/>	Front Windshield Defogger (if equipped)	<input type="checkbox"/>	Accessory Power Socket (if equipped)
<input type="checkbox"/>	Side Mirror Defogger (if equipped)	<input type="checkbox"/>	Heated/Vented Seats (if equipped)
<input type="checkbox"/>	Massage Seats (if equipped)		
<input type="checkbox"/>	Glove Box Light (if equipped)	<input type="checkbox"/>	Trunk or Back Door/Hatch Cancel Switch (if equipped)
<input type="checkbox"/>	Power Locks (if equipped)	<input type="checkbox"/>	Power Windows (if equipped)
<input type="checkbox"/>	Power Seats (if equipped)	<input type="checkbox"/>	Key Sensor Buzzer

