

Preparation

Part Number: PT392-34120

NOTE: Part number of this accessory may not be the same as the part number shown.

Kit Contents

Item #	Quantity Req'd.	Description
1	1	Curved Tube Assembly - Right
2	1	Curved Tube Assembly - Left
3	3	Center Tube
4	1	Hardware Bag
5	1	Right Mounting Bracket
6	1	Left Mounting Bracket
7	1	Installation Instructions
8	1	Care Card

General Applicability

All Tundra

Recommended Sequence of Application

Item #	Accessory
1	Bed Liner
2	Bed Extender
3	Bed Rug
4	Bed Cleat

*Mandatory

Hardware Bag Contents

Item #	Quantity Req'd.	Description
1	6	Thin Wedge
2	6	Thick Wedge
3	6	PT Screw
4	4	M8 x 25 Torx Head Bolt
5	2	Anti-Chip Tape

Vehicle Service Parts (may be required for reassembly)

Item #	Quantity Req'd.	Description
1		
2		
3		

Additional Items Required For Installation

Item #	Quantity Req'd.	Description

Conflicts

Note:

Recommended Tools

Personal & Vehicle Protection	Notes
Safety Glasses	
Blanket	
Special Tools	Notes
None	
Installation Tools	Notes
Tape Measure	
Torque Wrench	For Torx & Phillips bits
Rubber Mallet	Small
Screwdriver	#3 Phillips, Torx T-20&T-40
Special Chemicals	Notes
Cleaner	Approved Cleaner

Legend



STOP: Damage to the vehicle may occur. Do not proceed until process has been complied with.



OPERATOR SAFETY: Use caution to avoid risk of injury.



CAUTION: A process that must be carefully observed in order to reduce the risk of damage to the accessory/vehicle and to ensure a quality installation.



TOOLS & EQUIPMENT: Used in Figures calls out the specific tools and equipment recommended for this process.



REVISION MARK: This mark highlights a change in installation with respect to previous issue.



SAFETY TORQUE: This mark indicates that torque is related to safety.

Procedure

Care must be taken when installing this accessory to ensure damage does not occur to the vehicle. The installation of this accessory should follow approved guidelines to ensure a quality installation.

These guidelines can be found in the "Accessory Installation Practices" document.

This document covers such items as:-

- Vehicle Protection (use of covers and blankets, cleaning chemicals, etc.).
- Safety (eye protection, rechecking torque procedure, etc.).
- Vehicle Disassembly/Reassembly (panel removal, part storage, etc.).
- Electrical Component Disassembly/Reassembly (battery disconnection, connector removal, etc.).

Please see your Toyota dealer for a copy of this document.

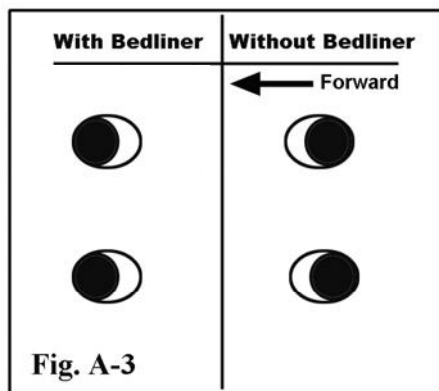
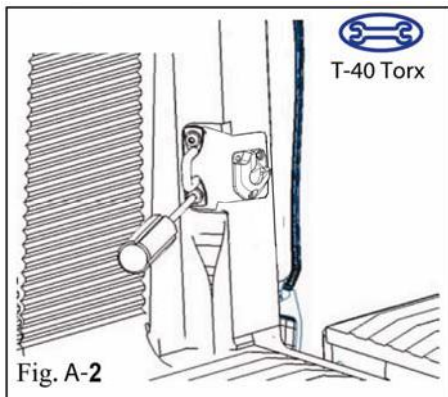
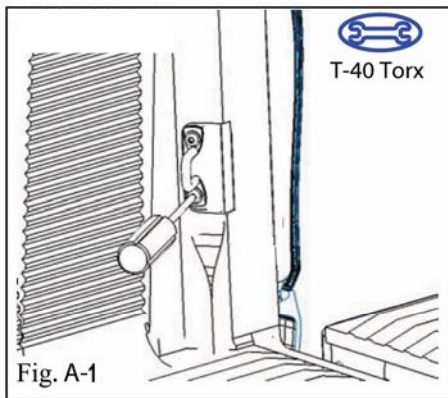

Right side (passenger) shown

A. Install Mounting Brackets.

1. Apply vehicle protection blanket, then using a T-40 Torx driver, remove the two bolts that attach the right (passenger side) cargo tie-down loop to the body (Fig. A-1).
 - (a) Discard the old bolts.
 - (b) Be careful not to scratch the vehicle.
2. Position the mounting bracket onto the truck bed. (Fig. A-2).
 - (a) If equipped with bed liner/bed rug, the mounting bracket lies on top of bed liner/bed rug.
 - (b) Be careful not to scratch the vehicle.
3. Using the T-40 Torx driver, bolt down angle bracket using OE tie-down loop and the provided bolts. (Fig. A-2).
 - (a) Tighten fasteners to 17.5 N-m (13 lbf-ft.)
 - (b) The slotted mounting holes of the bracket allow an adjustment for the clearance of the bed liner/bed rug, forward for trucks without a bed liner/bed rug. (Fig. A-3).
4. Repeat procedure (Steps A-1 to A-3) for the left (driver side) cargo tie-down loop and the left angle bracket.

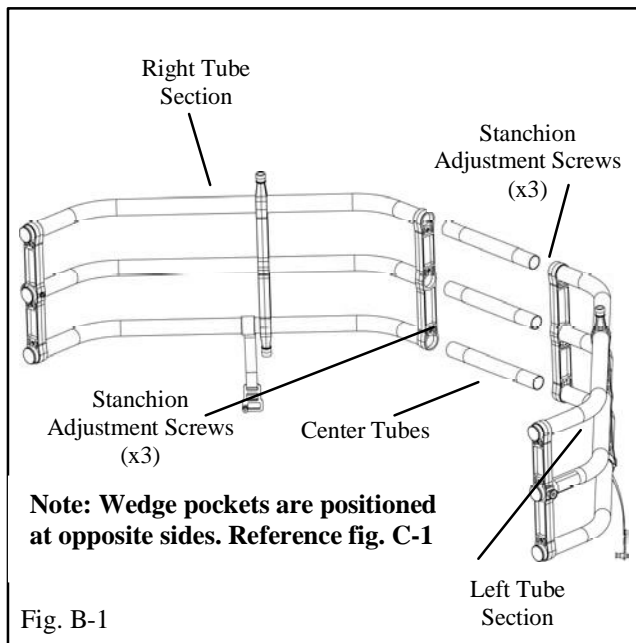

B. Assemble and Install Bed Extender.

1. Loosely join the center tubes to the right tube section, then the left tube section, as shown, beyond the non-powder coated sections (Fig. B-1).
 - (a) Do not allow bare metal to be exposed.
2. Adjust the Bed Extender assembly width by sliding the right/left tube sections in or out on the center tubes so that the assembly can be installed into the mounting brackets as shown in Fig. B-2.

Operation of Angled Bracket

To install, rotate Bed Extender 55° from tailgate and slide the pivots into mounting brackets as shown in Figure B-2

To remove, rotate Bed Extender 55° from tailgate and slide pivots out of mounting brackets. Make sure that the two straps are facing rearward.

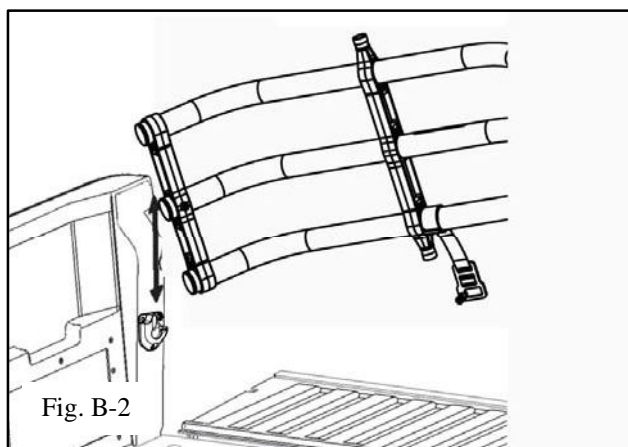

C. Positioning of Center Tube Stanchions.

1. Rotate the assembly onto the open tailgate.

NOTE: It is normal for the Bed Extender to have some resistance, when first rotated in the bracket.

2. Move the right center stanchion over the right tube section by tapping with a rubber mallet.
 - (a) Be careful not to scratch the center tubes.
 - (b) Excessive force may damage extender and/or vehicle.
3. Insert wedges into the three (3) wedge pockets of stanchion on both sides of the each stanchion (Fig. C-1)

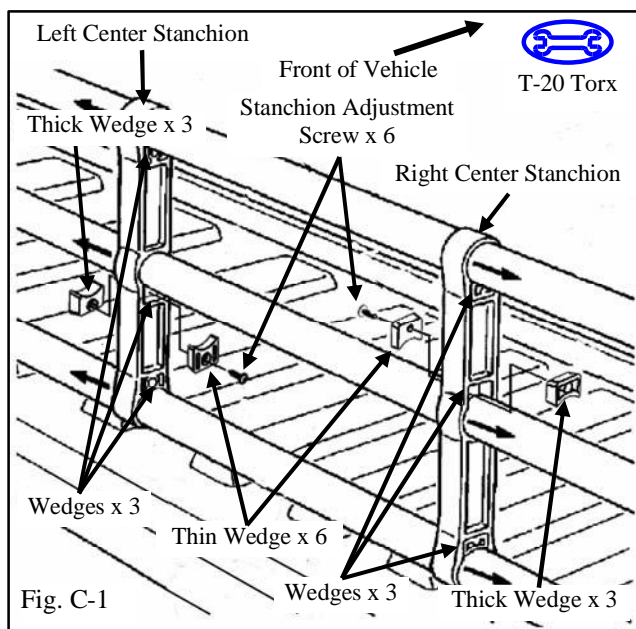

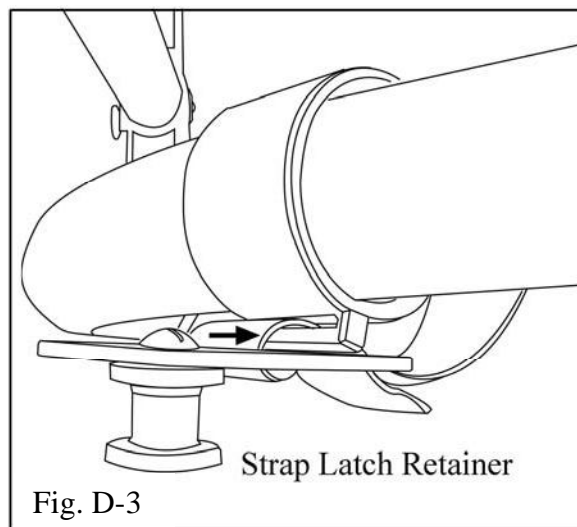
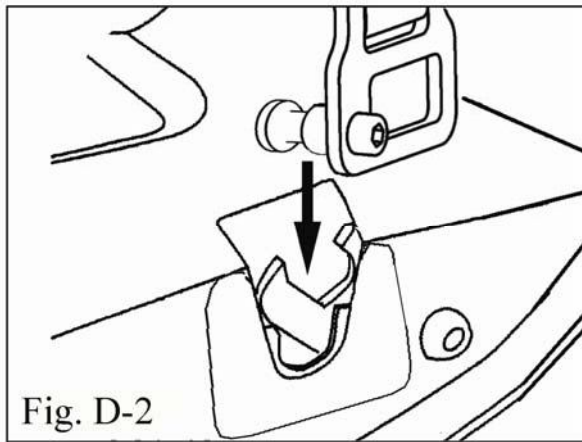
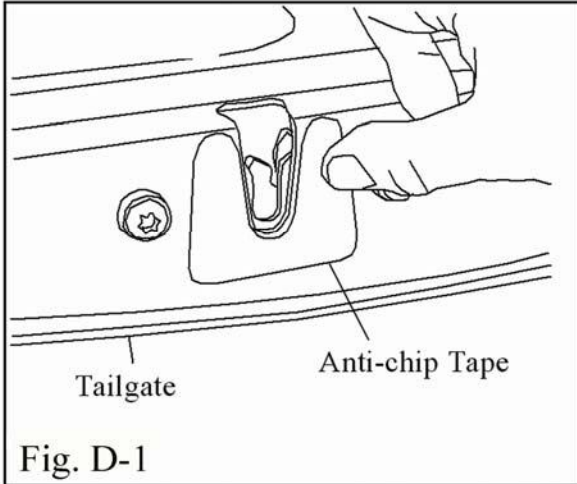

- (a) The thinner wedges face the center of the Bed Extender.
- 4. Insert three (3) stanchion adjustment screws from center of Bed Extender.
- 5. With a T-20 Torx wrench, tighten the three (3) screws after stanchion is securely in place to 2.3 N-m (20 lbf-in.).

D. Adjustment of Locking Straps.

- 1. Install Anti-Chip Tape onto tailgate latch area as shown in (Fig. D-1).
 - (a) Clean surface before installing Anti-Chip Tape using an approved cleaner. Do not allow cleaner to air dry.
- 2. Adjust strap length and position in order to allow plastic insert to lock into tailgate. (Fig. D-2)



- (a) When the Extender is in the inward position, clip the straps onto the Strap Latch Retainer as shown in (Fig. D-3). This will prevent the buckles from rattling.

E. Care Card





- 1. Place the care card in the glove box.

Checklist - these points **MUST** be checked to ensure a quality installation.

Check:

Accessory Function Checks

-  Bed Extender adjustment

-  Tailgate strap adjustment

- Torque adjustment of stanchion screws

- Torque adjustment of mounting bolts

- Upright foot positioning in bed and on tailgate

Look For:

- Bed extender pivot point must rest in mounting brackets.

- Tailgate straps must be able to lock into tailgate locks.

- Stanchion screws must be tightened to 2.3 N-m (20 lbf-in.).

- Bracket mounting bolts must be tightened to: 17.5 N-m (13 lbf-ft.)

- Ensure that upright feet sit properly on a flat surface on the tailgate edge and inside the bed. With bed liner, within the pad.

Vehicle Function Checks

- Tailgate latch

Strap latch retainer can be released from the tailgate latch