

Part Number: PT374-02090

Kit Contents

Item #	Quantity Reqd.	Description
1	1	Auto Dimming Mirror Assembly w/ shift area light
2	1	Hardware bag

Hardware Bag Contents

Item #	Quantity Reqd.	Description
1	2	T-tap Connectors, Red 3M™
2	1	Wire Cover (short)
3	1	Wire Cover (long)
4	1	EC Wire Harness
5	9	Foam Tape
6	6	Wire Ties, small
7	1	Corrugated tubing
8	1	Operation Instruction Card

Additional Items Required For Installation

Item #	Quantity Reqd.	Description

Conflicts

Models without power outside mirrors.

Recommended Tools

Personal & Vehicle Protection	Notes
Blankets, Towels	
Special Tools	Notes
None	
Installation Tools	Notes
Ratchet	
Socket	10 mm
Torx Head Driver	T20
Pliers	Needle Nose
Side cutters	
Nylon Panel Removal Tool	e.g. Panel Pry Tool #1 Toyota SST# 00002-06001-01
Dark Towel or Cloth	For Testing
Torque Wrench	15.5 lbf-in, 36 lbf-in
Masking tape	
Electrical tape	
Scissors	
Wire fishing tool	(Optional)

Special Chemicals	Notes
Cleaner	3M™ Prep Sol-70

General Applicability

Models WITH power outside mirrors.

Recommended Sequence of Application







Item #	Accessory
1	Security System
2	RES
3	Satellite Radio
4	EC Rearview Mirror

*Mandatory

Vehicle Service Parts (may be required for reassembly)

Item #	Quantity Reqd.	Description
1	1	62217-52070, A pillar clip.
1	1	74318-52020-B0, Driver side visor clip cover, Gray 74318-52020-E0, Driver side visor clip cover, Beige

Legend

	STOP: Damage to the vehicle may occur. Do not proceed until process has been complied with.
	OPERATOR SAFETY: Use caution to avoid risk of injury.
	CAUTION: A process that must be carefully observed in order to reduce the risk of damage to the accessory/vehicle and to ensure a quality installation.
	TOOLS & EQUIPMENT: Used in Figures calls out the specific tools and equipment recommended for this process.
	REVISION MARK: This mark highlights a change in installation with respect to previous issue.
	SAFETY TORQUE: This mark indicates that torque is related to safety.

Care must be taken when installing this accessory to ensure damage does not occur to the vehicle. The installation of this accessory should follow approved guidelines to ensure a quality installation.

These guidelines can be found in the "Accessory Installation Practices" document.

This document covers such items as:-

- Vehicle Protection (use of covers and blankets, cleaning chemicals, etc.).
- Safety (eye protection, rechecking torque procedure, etc.).
- Vehicle Disassembly/Reassembly (panel removal, part storage, etc.).
- Electrical Component Disassembly/Reassembly (battery disconnection, connector removal, etc.).

Please see your Toyota dealer for a copy of this document.

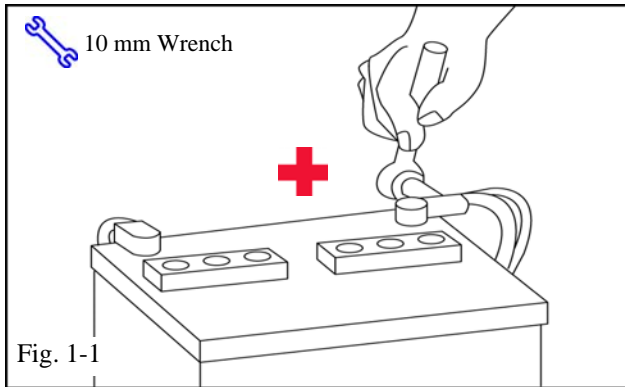

1. Remove Battery Cable.

- (a) Protect fender before starting.
- (b) Do not touch the positive terminal with any tool when removing cable.
- (c) Remove the negative battery cable. (Fig. 1-1)

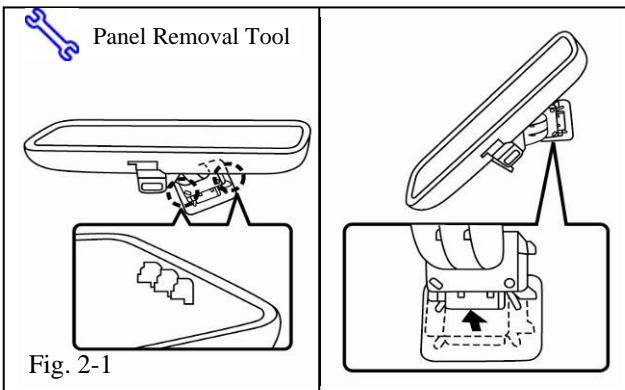

2. Vehicle Disassembly.

- (a) Remove the OE mirror.
 - (1) Disengage the two claws and remove the mirror cover from the mirror base. (Fig. 2-1)
 - (2) Pull the lever in the direction indicated by the arrow shown in the illustration and slide the inner rear view mirror assembly upward to remove it. (Fig. 2-1)

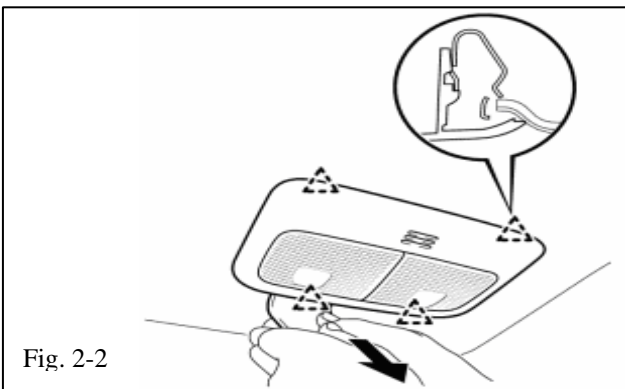

- (b) Using panel removal tool remove map light assembly from headliner. (Fig. 2-2)
 - (1) Disconnect the map light connector.

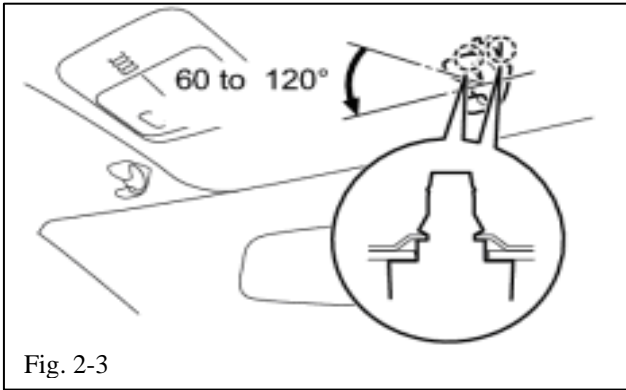

(c) Disengage both driver side and passenger side sun visor holders from the roof by rotating counter clockwise between 60 to 120°. (Fig. 2-3)

(1) Do not completely remove visor holders from the headliner.

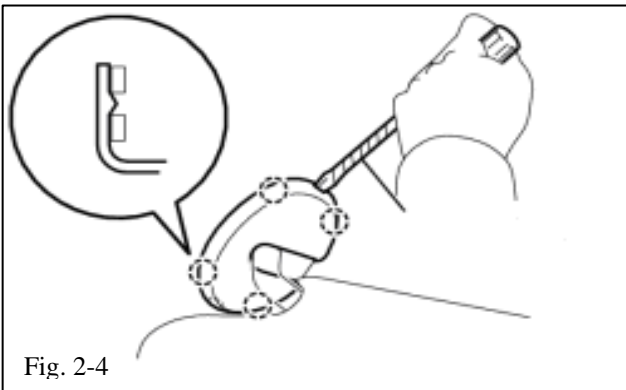

(d) Using panel removal tool, pry DRIVER SIDE visor mount cover off from visor mount. (Fig. 2-4)



(1) DO NOT fully remove cover.

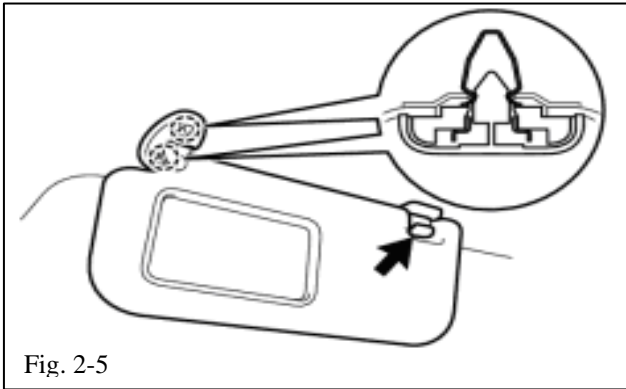

(e) Using panel removal tool, pry downward on visor mount to disengage two (2) clips and remove visor. (Fig. 2-5)

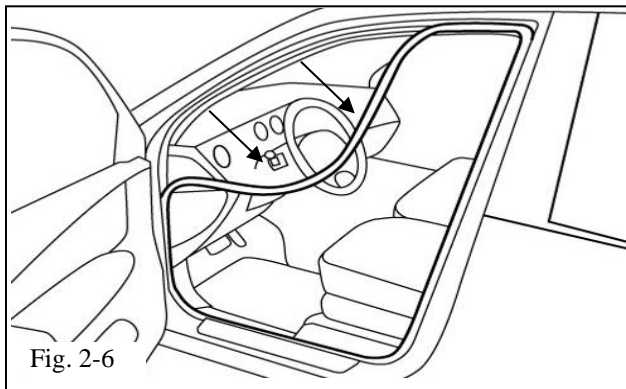

(f) Pull weather-stripping down past top of A-pillar garnish. (Fig. 2-6)

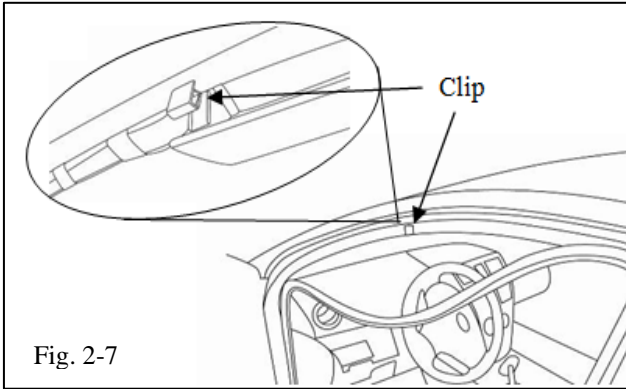

Fig. 2-7

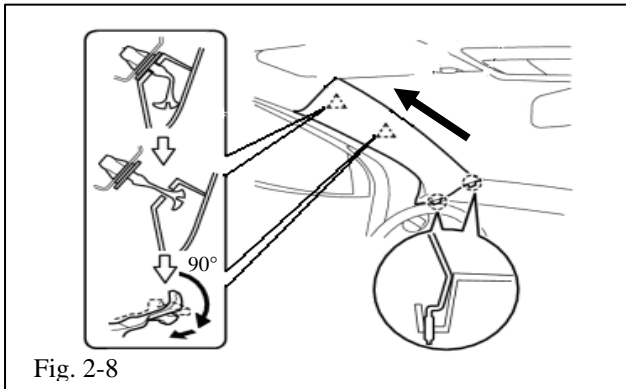

Fig. 2-8

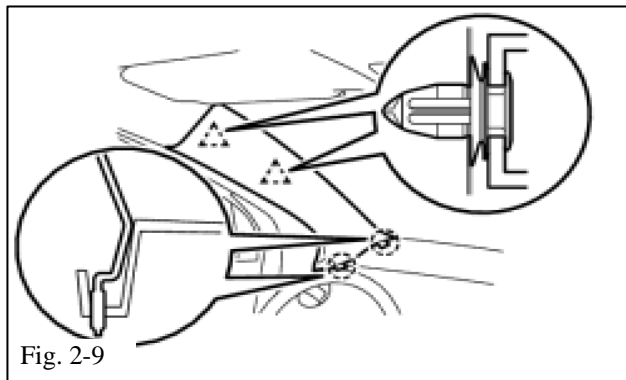

Fig. 2-9

- (1) When pulling down the weather strip, if the metal headliner clip pops off, replace the clip to its original position as shown. (Fig. 2-7)

(g) Detach A-pillar garnish from body.

WITH Curtain Side Airbags:

- (1) Starting from the top, pull the A pillar garnish outward so that the top clip and center clip detach from the A pillar garnish and the tip of the clips lock in the pillar garnish's hole. (Fig. 2-8)



- (2) Note the orientation of the clips.



- (3) Put masking tape around the jaws of the needle-nose pliers to prevent clip damage.

- (4) Using needle-nose pliers, rotate the center portion of the top clip 90°, then pull the pillar garnish to release the tip of the top clip from the pillar garnish. (Fig. 2-8)

- (5) Using the same method above, release the pillar garnish from the center clip.



- (6) **DO NOT** remove the clips from the A-pillar body. If the clips show any sign of damage or are removed from the body, replace with a new clip.

- (7) Pull the pillar garnish in the direction indicated by the arrow in the illustration to detach the bottom claws. (Fig. 2-8)

WITHOUT Curtain Side Airbags:

- (8) Disengage the 2 clips and the 2 claws and remove the front pillar garnish. (Fig. 2-9)

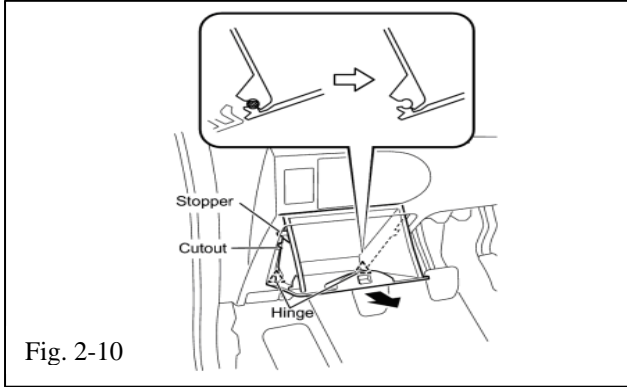

(h) Remove the driver side storage compartment.

- (1) Open storage compartment. (Fig. 2-10)
- (2) Pull the hinge side of the instrument panel box out horizontally with the instrument panel open and disengage the 2 hinges. (Fig. 2-10)

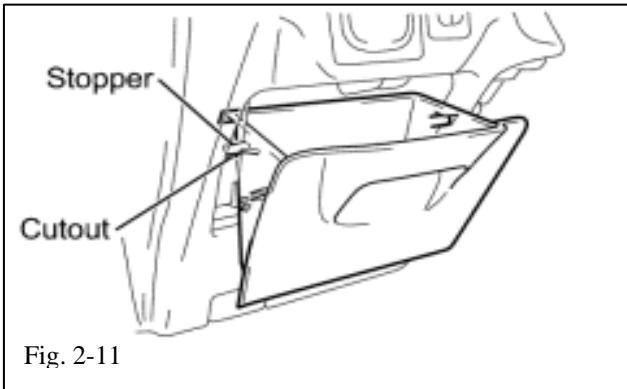

- (3) Remove the stopper of the instrument panel box from the cutout of the instrument panel lower and remove the instrument panel box. (Fig. 2-11)

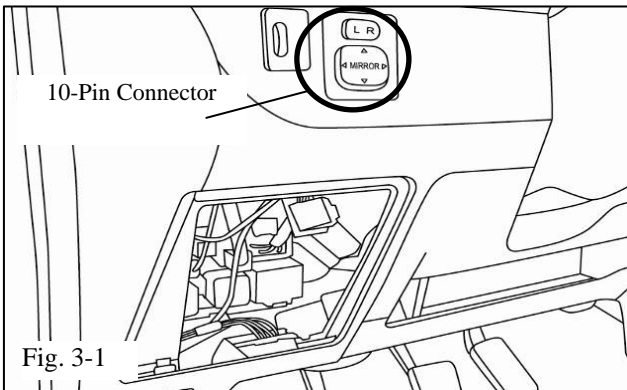

3. Install T-taps.

- (a) Locate and disconnect the 10 pin connector behind the Outer Mirror Switch. (Fig. 3-1)

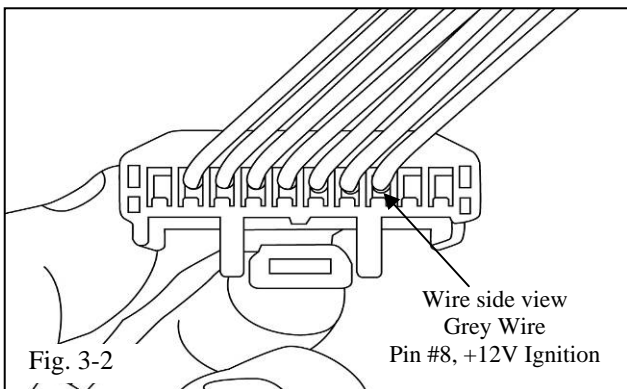

- (b) Locate the GREY wire in pin #8 on the 10 pin connector. (Fig. 3-2)



- (1) If necessary, remove the electrical tape above the connector to gain access to the wires.

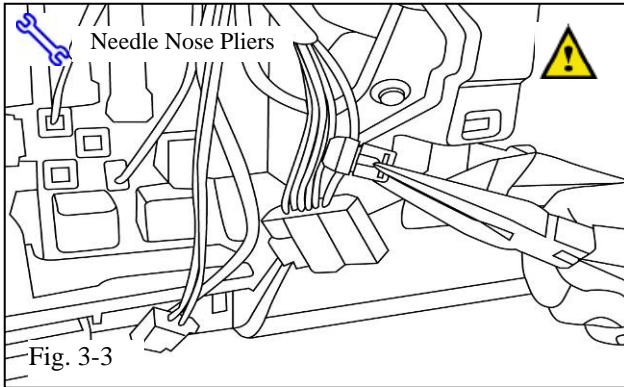

- (c) Attach T-tap connector to GREY wire (pin #8) on the 10 pin connector with needle-nose pliers about 1 inch from the connector. (Fig. 3-3)



- (1) Ensure both halves of T-tap connector are snapped together.

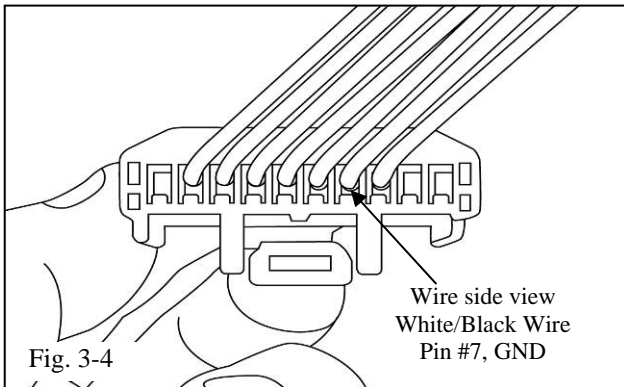

- (d) Locate the WHITE/BLACK wire in pin #7 on the 10 pin connector. (Fig. 3-4)

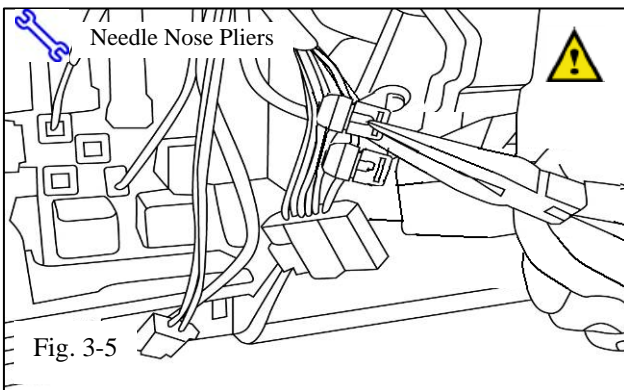

- (e) Attach T-tap connector to WHITE/BLACK wire (pin #7) on the 10 pin connector with needle-nose pliers about 1.5 inches from the connector. (Fig. 3-5)



- (1) Ensure both halves of T-tap connector are snapped together.

4. Install EC Mirror.

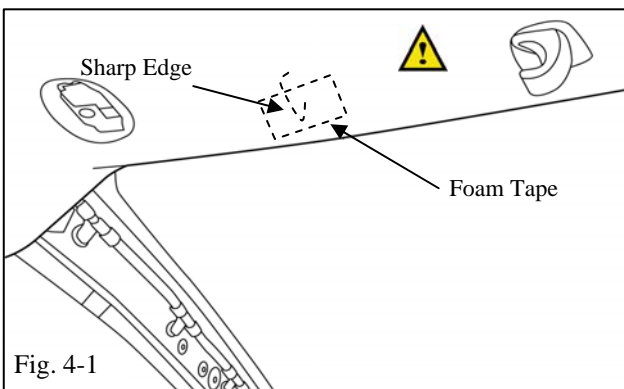

- (a) Gently pull headliner down and locate sharp edge on the roof, mid-way between visor clip and visor mount opening. (Fig. 4-1)

- (1) Do not use excessive force when pulling headliner, this may cause headliner to crease.
- (2) Place one (1) piece of foam tape over sharp edge on the roof to protect EC mirror harness.

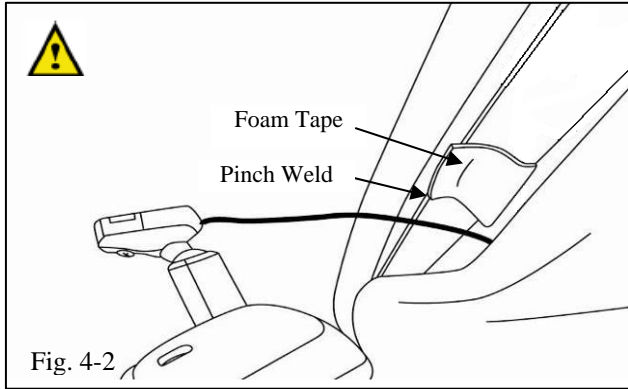

- (b) Apply one (1) piece of foam tape to the pinch weld between the windshield and the headliner above the center of the mirror. (Fig. 4-2)



- (1) Do not use excessive force when pulling headliner, this may cause headliner to crease.

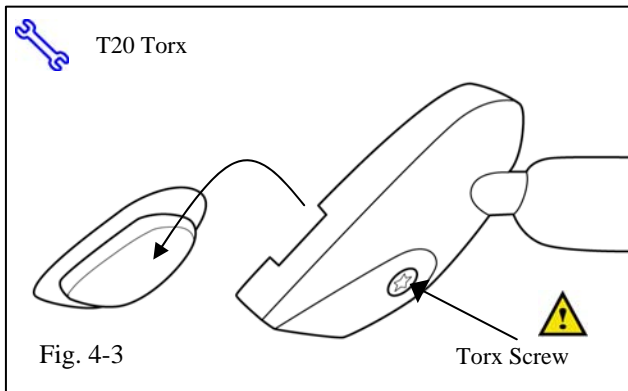

- (c) Slide the EC mirror onto the mounting button on windshield. (Fig. 4-3)



- (d) Tighten the screw in the mirror mounting bracket with torque wrench to 1.75 N-m (15.5 lbf-in).

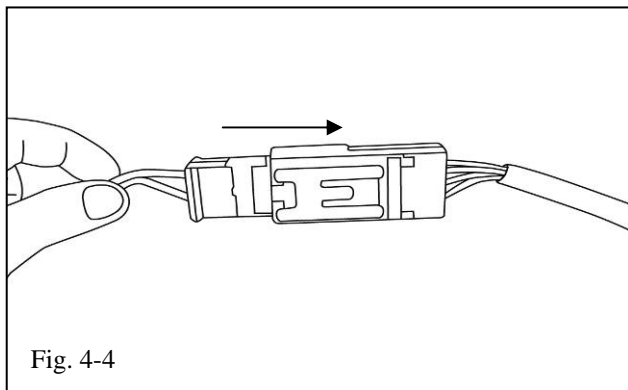

- (e) Plug EC wire harness 2-pin connector into the 2-pin mirror harness. (Fig. 4-4)

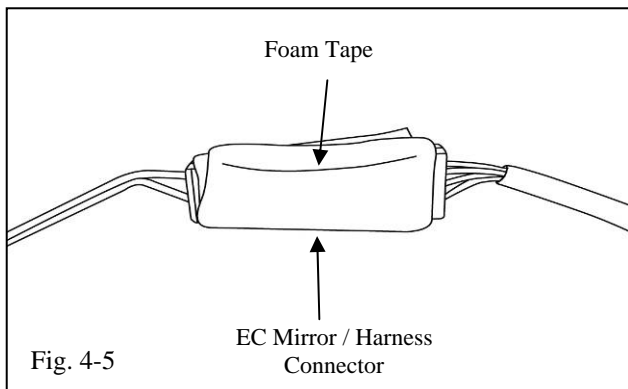

- (f) Wrap one (1) piece of foam tape around EC mirror connector and EC harness connector. (Fig. 4-5)

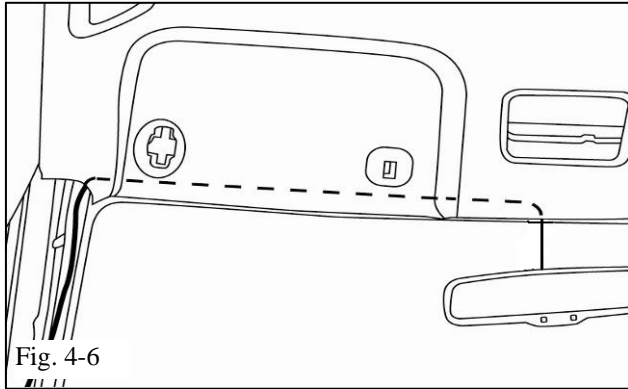

- (g) Route the wire along the bottom curve of the headliner toward the Driver Side A-pillar. (Fig. 4-6)

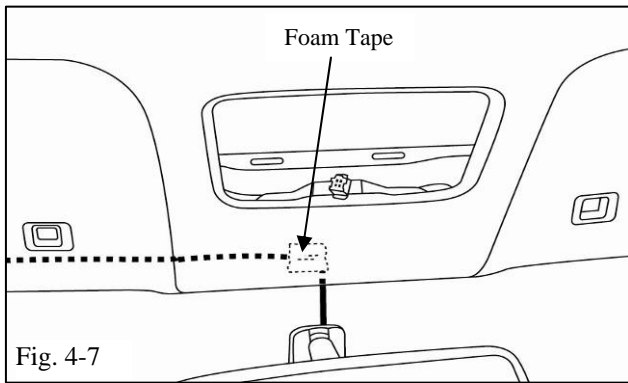

- (h) Secure the harness to the front center of the headliner with one (1) piece of foam tape. (Fig. 4-7)

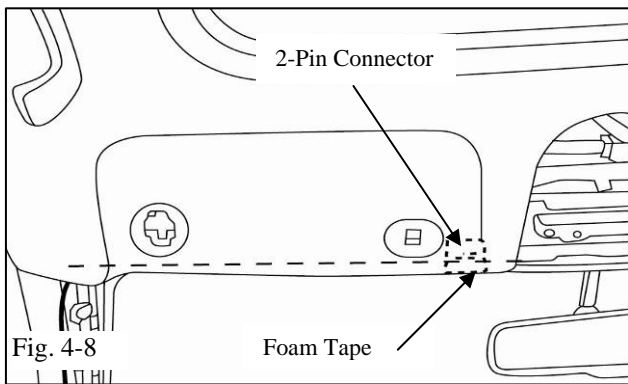

- (i) Secure the connector to the headliner with (1) piece of foam tape in an open location to the right of the sun visor holder. (Fig. 4-8)
- (1) Ensure EC harness connector does not cause interference with visor holder, headliner, and roof of vehicle.

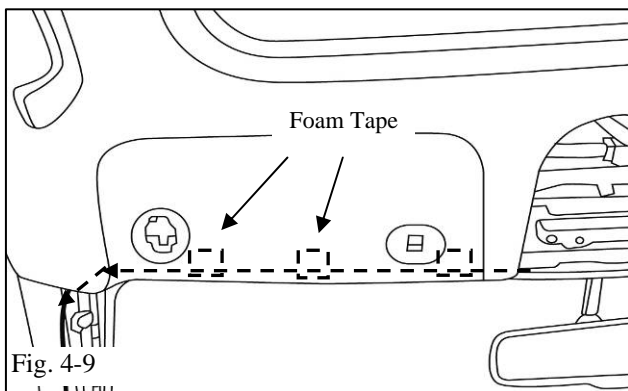

- (j) Secure the harness in the visor area to the headliner with two (2) pieces of foam tape in the locations shown. (Fig. 4-9)
- (1) Make sure the wire harness does not block any of the visor mounting holes.



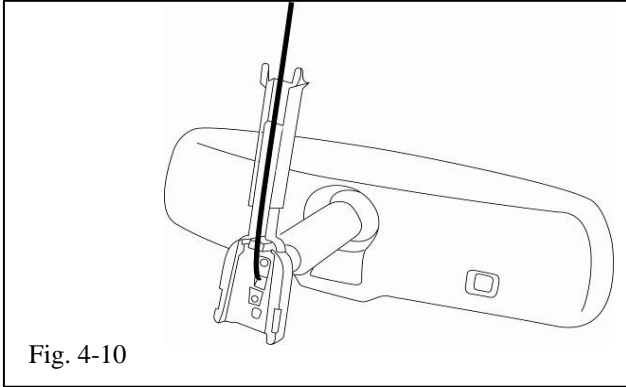

(k) Install the LONG wire harness cover over the wire harness. (Fig. 4-10)

- (1) Seat the bottom of the cover to the mirror. Make sure it is snapped into place.
- (2) Extend the top of the cover fully into headliner.

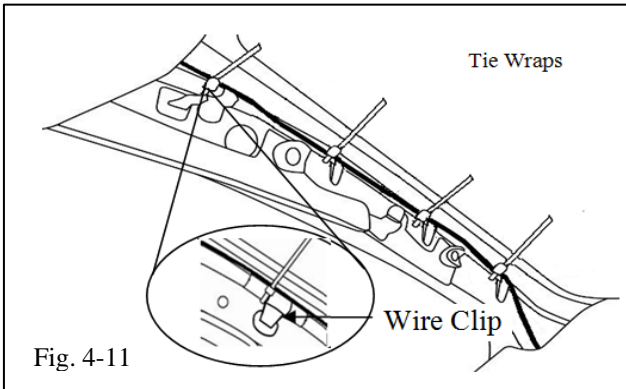

(l) Route EC mirror harness down vehicle A-pillar ABOVE the OE harness. Secure the wire harness to the OE harness with four (4) tie wraps in front of each wire clip. (Fig. 4-11)



(1) Verify mirror harness will not interfere with airbag deployment.

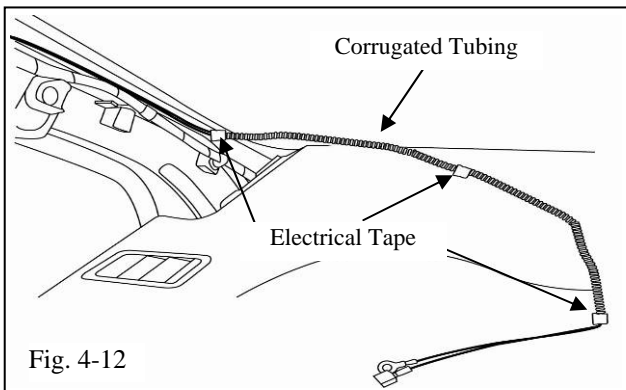

(m) Apply corrugated tube to the remaining portion of the wire about 1 inch from the last wire tie. (Fig. 4-12)

- (1) Use electrical tape to secure the wire in the tube at the top to the wire at the top, in the middle, and at the bottom of the tube.

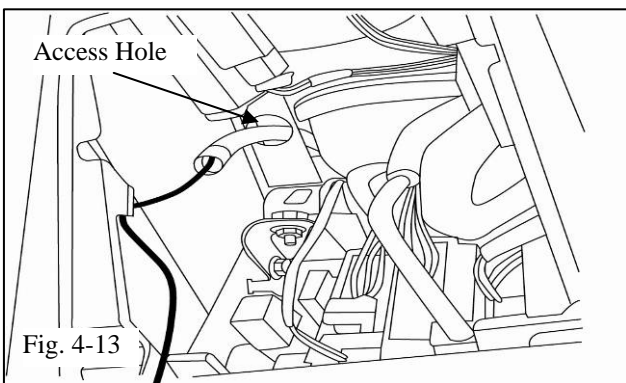

(n) Carefully route harness through center dash panel, in front of the support bar and through the access hole near support bar. (Fig. 4-13)

- (1) For ease of installation, use a wire fish tool to guide harness through hole.
- (2) Use care when routing through the center dash, as there are many sharp edges. (Fig. 4-13)



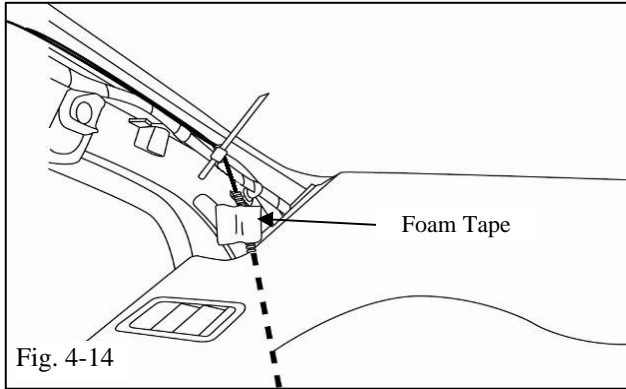

- (o) Secure the corrugated tube to the bottom of the A pillar body with one (1) piece of foam tape. (Fig. 4-14)

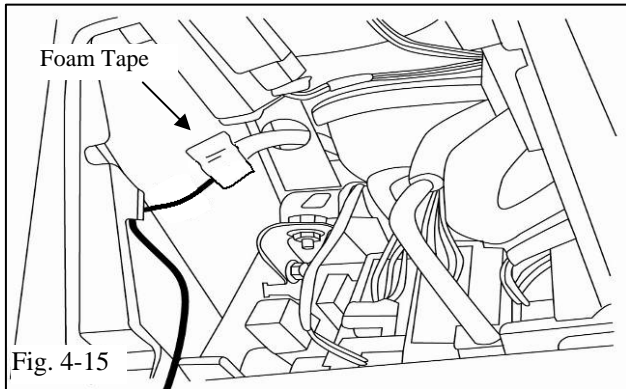

- (p) Secure corrugated tube to the side of the center dash with one (1) piece of foam tape as shown. (Fig. 4-15)
- (1) Make sure the tube between the A pillar and access hole is not loose and will not rattle.

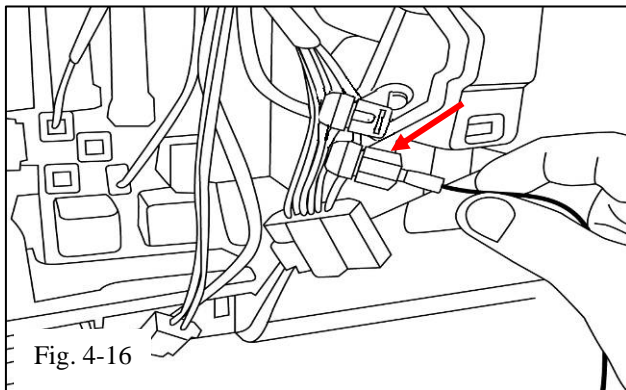

- (q) Plug the BLACK/RED wire spade end of the EC mirror harness into T-tap connector on the GREY wire. (Fig. 4-16)



- (1) Ensure that the spade end is properly seated in the T-tap.

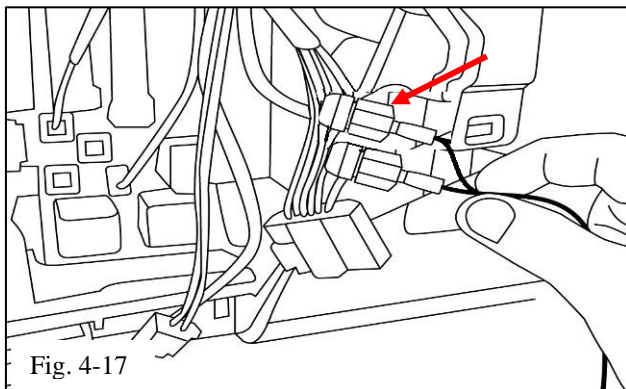

- (r) Plug the BLACK wire spade end of the EC mirror harness into T-tap connector on the WHITE/BLACK wire. (Fig. 4-17)



- (1) Ensure that the spade end is properly seated in the T-tap.

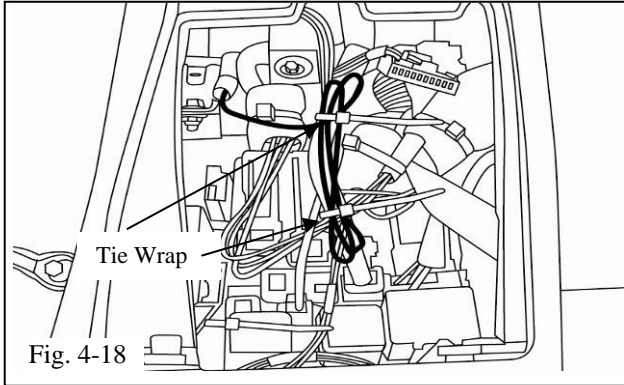

- (s) Reconnect the Outer Mirror Switch connector.
- (t) Bundle any excess wire and secure it to the OE harness on the junction block as shown with two (2) tie wraps. (Fig. 4-18)

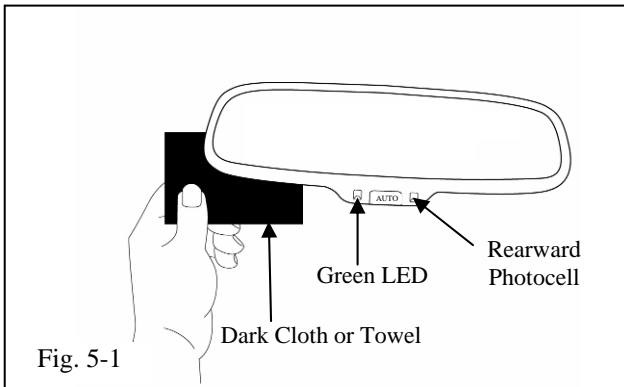

5. Testing

- (a) If not installed, install the short pin located in the engine compartment fuse box.
- (b) Temporarily reconnect the vehicle's negative battery cable.
- (c) Turn ignition switch to ON.
- (d) With the vehicle in a fairly well lit area, perform the following test:
 - (e) Auto Dimming Feature:
 - (1) To make sure the auto-dimming feature is on, verify that the LED indicator light is on. If it is not on, push the "On/Off" button for 3 seconds, or until the LED is illuminated.
 - (2) Cover the forward-looking light sensor located on the back of the mirror with a dark cloth or towel. (Fig. 5-1)
 - (3) In a few seconds, the mirror will begin to darken (time may vary with ambient light levels).
 - (4) Remove the cover from the forward-looking light sensor and the mirror will begin to clear.

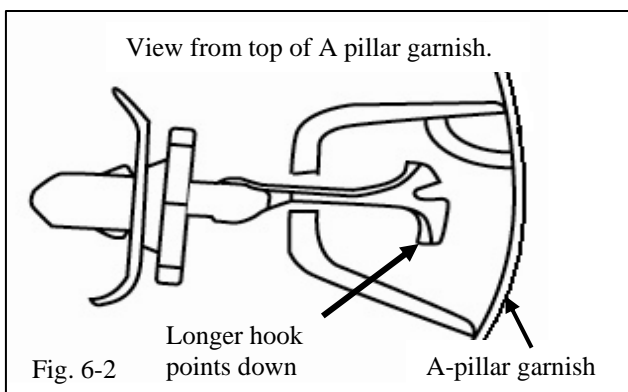
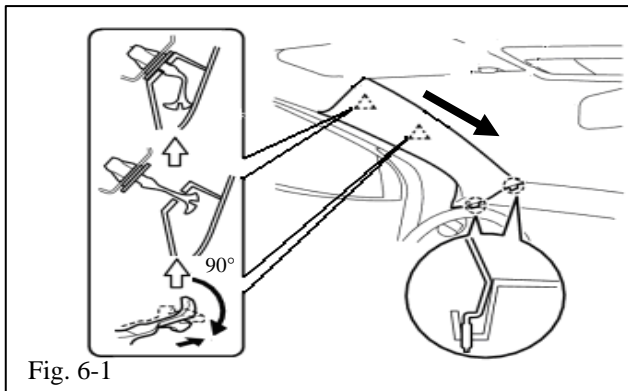
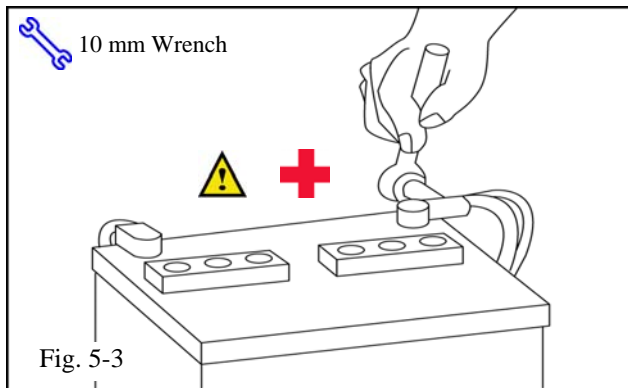
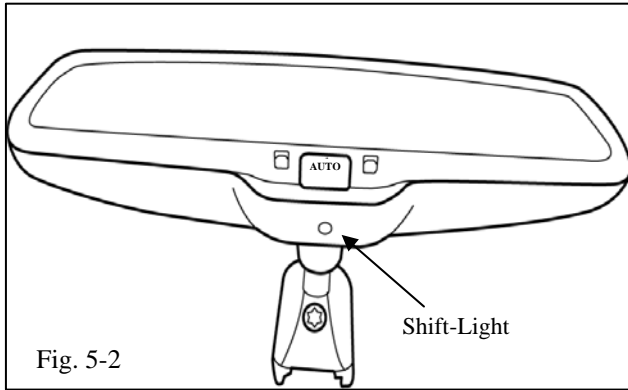

(f) Shift-light Feature:

(1) With ignition ON, cover forward-looking light sensor on back of the mirror. Low-level ambient lighting should be visible from the bottom of the mirror. (Fig. 5-2)

(2) Turn ignition OFF.

(g) Disconnect the negative battery terminal. (Fig. 5-3)

6. Final Assembly.

(a) Trim excess off all tie wraps.

(b) Re-install the driver side sun visor assembly, hinge cover, and visor holders.

(c) Reconnect the map light connector and install the map light assembly.

(d) Re-install the driver side storage compartment.

(e) Re-install the A pillar garnish.

WITH Curtain Side Airbags:

(1) Inspect both A pillar clips. If they are damaged, replace them. (Fig. 6-1)

(2) Set the claws of the lower A pillar garnish into the upper IP. (Fig. 6-1)

(3) Insert the tip of the center clip into the pillar garnish's hole by using needle-nose pliers to rotate the tip of clip 90°.

 (4) Make sure the clip is in the proper orientation and locks into the garnish hole. (Fig. 6-2)

 (5) Ensure that clip is properly secure in the A pillar garnish, and that the clip is properly engaged in the garnish when in the deployed position.

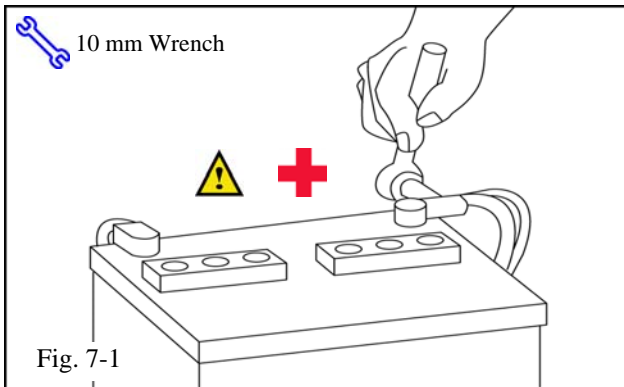
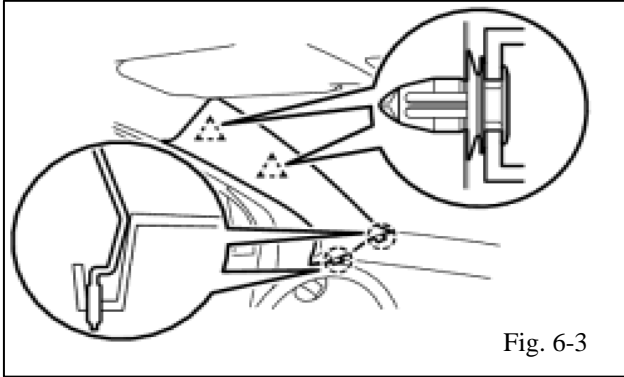

(6) Using the same method above, install the A pillar garnish to the top clip.



(7) Before installing the A pillar garnish, be sure the air bag or wire harnesses will not get pinched or tangled.

(8) Push the pillar garnish toward the vehicle body to attach the base of the top clip and the center clip.

WITHOUT Curtain Side Airbags:

(9) Set the claws of the lower A pillar garnish into the upper IP. (Fig. 6-3)

(10) Engage the 2 clips. (Fig. 6-3)

(f) Reinstall the weather seal.

(g) Ensure components are securely fastened and do not interfere with existing OE or EC harnesses.

(h) Place the operation instruction card in the vehicle glove box.

(i) Remove fingerprints, smudges, dirt, etc. from mirror and windshield with a 3M™ Prep Sol-70.

(j) Verify each reinstalled component for proper fit and function.

7. Reconnect Negative Battery Cable.

(a) Reconnect the vehicle's negative battery cable. (Fig. 7-1)



(1) Tighten the nut to 4.1 N-m (36 lbf-in)



(2) Do not touch the positive terminal with any tools when replacing the cable.

Checklist - these points **MUST** be checked to ensure a quality installation.

Check:

Accessory Function Checks

Vehicle should be in a fairly well lit area.

- Turn ignition (ACC power) to ON.

Auto-dimming feature:

- Cover the forward-looking light sensor (located on the back of the mirror).

Mirror clears:

- Remove cover from forward-looking light sensor.

Shift-light Feature:

- Turn ignition ON, cover forward-looking light sensor and observe shift-light.
- Operation Instruction Card

Look For:

Verify green LED is on. If it is not ON press On / Off button - confirm LED is ON.

Verify mirror darkens.

Mirror returns to clear state.

Light is visible from bottom of mirror.

Placed in the vehicle glove box.

Vehicle Function Checks

- Check map lights.
- Check power mirrors.

Verify map lights function properly.

Verify power mirrors function properly.