

Preparation

**Part Number:**

**PT29A-08100 (Bright Chrome Finish)**

**PT29A-08110 (Semi Chrome Finish)**

**Kit Contents**

Item #	Quantity Req'd.	Description
1	1	LH Front Door Molding
2	1	LH Rear Door Molding
3	1	RH Front Door Molding
4	1	RH Rear Door Molding

**Hardware Bag Contents**

Item #	Quantity Req'd.	Description
1		
2		

**Additional Items Required For Installation**

Item #	Quantity Req'd.	Description
1		
2		

**Conflicts**

--

**Recommended Tools**

<b>Personal &amp; Vehicle Protection</b>	<b>Notes</b>
Safety Glasses	
Vehicle Protection	
<b>Special Tools</b>	<b>Notes</b>
<b>Installation Tools</b>	<b>Notes</b>
Lint Free Cloths	
Non-Intrusive Infrared Temp Probe/Gun	
Roller	Hard rubber hand roller, 1" to 3" wide.
Heat source	
Blue or green masking tape	2" wide
<b>Special Chemicals</b>	<b>Notes</b>
Vehicle Cleaner	3M™ Prep Solvent or a 50/50 mixture of water and isopropyl alcohol.

**General Applicability**

-08100 (Bright Chrome Finish): All grades except SE.
-08110 (Semi Chrome Finish): SE grade only.

**NOTE:** Part number of this accessory may not be the same as the part number shown.

**Recommended Sequence of Application**

Item #	Accessory
1	Lower Door Moldings can be installed in any sequence with other accessories.
2	

\*Mandatory

**Vehicle Service Parts** (may be required for reassembly)

Item #	Quantity Req'd.	Description
1		
2		

**Legend**

 **STOP:** Damage to the vehicle may occur. Do not proceed until process has been complied with.

 **OPERATOR SAFETY:** Use caution to avoid risk of injury.

 **CAUTION:** A process that must be carefully observed in order to reduce the risk of damage to the accessory/vehicle and to ensure a quality installation.

 **TOOLS & EQUIPMENT:** Used in Figures calls out the specific tools and equipment recommended for this process.

 **REVISION MARK:** This mark highlights a change in installation with respect to previous issue.

 **SAFETY TORQUE:** This mark indicates that torque is related to safety.



Care must be taken when installing this accessory to ensure damage does not occur to the vehicle. The installation of this accessory should follow approved guidelines to ensure a quality installation.

These guidelines can be found in the "Accessory Installation Practices" document.

This document covers such items as:

- Vehicle Protection (use of covers and blankets, cleaning chemicals, etc.).
- Safety (eye protection, rechecking torque procedure, etc.).
- Vehicle Disassembly/Reassembly (panel removal, part storage, etc.).
- Electrical Component Disassembly/Reassembly (battery disconnection, connector removal, etc.).

Please see your Toyota dealer for a copy of this document.



Fig. 1-1

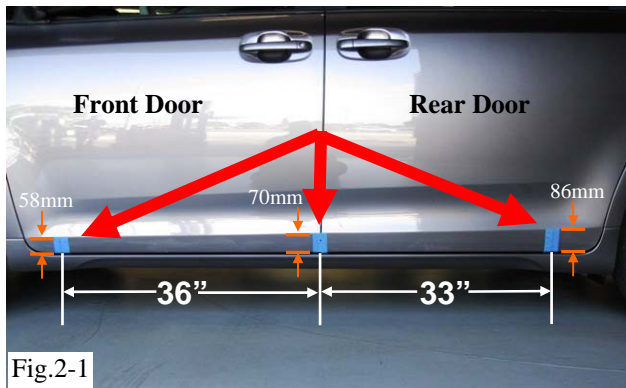



Fig.2-1



Fig.2-2

## 1. Vehicle Preparation

-  (a) The work area, Lower Door Moldings, and vehicle door surfaces must be at least 60° F at the time of the actual installation.
- (b) Saturate a clean lint-free cloth with 3M™ Prep Solvent-70 and clean the lowest 10" of all four doors where the moldings will be installed. The indicated area has been highlighted in (Fig 1-1).

-  (1) When cleaning with 3M™ Prep Solvent-70, follow the manufacturer's directions. Do not allow cleaner to air dry.

-  **NOTE:** Once cleaned do not contaminate this surface by touching it with your bare hands.

## 2. Lower Door Molding Installation

- (a) Place strips of 2" wide tape at the three places shown (Fig 2-1). Mark and trim the tape using a straight edge held parallel to the feature line near the bottom of the doors as shown (Fig 2-2).

**NOTE:** The paint protection film on the back of the rear doors does not need to be removed and the Lower Door Molding will install over the top of the film.

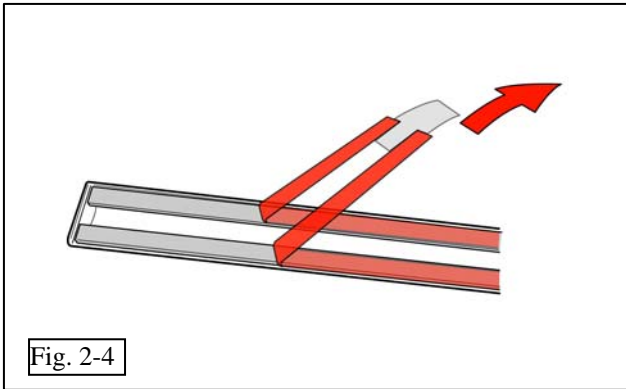
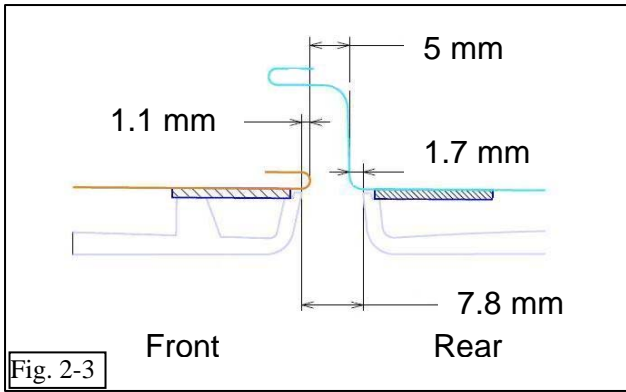

(b) The moldings are designed so that their bottom edges are even with the top edges of the three vertical tape pieces and are located relative to the edges of the front and rear doors as shown (Fig 2-3).

(c) The long moldings are for the front doors, while the shorter moldings are for the rear doors. Each molding is marked LH or RH on the back side. Starting with the rear molding, while carefully holding the molding by its edges, pull the plastic tape at the end of the part to remove the tan release liner from the gray acrylic foam tape strips. (Fig. 2-4)



**NOTE:** Once the release liner is removed from the molding, the surface of the foam tape must not be touched!

(d) While holding the top of the LH rear molding approximately 1/2" out from the surface of the door, carefully touch the molding to the door as shown in (Figs. 2-3 & 2-5) while simultaneously resting the bottom edge on the tops of the tape strips. While keeping the molding resting on top of the tape strips, press the molding against the door. Ensure the molding is adhered by sliding your fingers from the front to the back while pressing against the molding.

(e) Repeat steps 2 (c & d) for the LH front molding. Carefully touch the molding to the door, while keeping the molding resting on top of the tape strips. While keeping the molding resting on top of the tape strips, press the molding against the door. Ensure the molding is adhered by sliding your fingers from the rear to the front while pressing against the molding. (Fig 2-6)



- (f) Using the hand roller, roll around the perimeter of the parts with a firm pressure to ensure complete adhesion of the acrylic foam tape to the door surfaces (Fig. 2-7).
- (g) Repeat the entire installation procedure for the passenger side of the vehicle.

**TOYOTA SIENNA MY 2011 - LOWER DOOR MOLDING**  
Checklist - these points **MUST** be checked to ensure a quality installation.

Check:

Look For:

Accessory Function Checks

Check for visual alignment

The moldings should follow the door character line and at the same height where the front and rear moldings meet between the doors.

No part of the moldings should extend beyond the edges of the doors.

Check for proper tape adhesion

A gap of approximately 1.3 mm (0.05”) is designed to exist between the edges of the Moldings and the vehicle door surfaces.

No gap is allowed between the tape and the vehicle door surfaces, except where the tape segments join on the back side.

Vehicle Function Checks

None Required