

Part Number: PT29A-02095-XX

Kit Contents

Item #	Quantity Reqd.	Description
1	1	Molding, LH Front Door
2	1	Molding, LH Rear Door
3	1	Molding, RH Front Door
4	1	Molding, RH Rear Door
5	1	Instruction sheet

Hardware Bag Contents

Item #	Quantity Reqd.	Description
1		
2		

Additional Items Required For Installation

Item #	Quantity Reqd.	Description
1		
2		

Conflicts

None

Recommended Tools

Personal & Vehicle Protection	Notes
Safety Glasses	
Vehicle Protection	Seat & Floor Covers
Special Tools	Notes
Roller	Hard Rubber Hand Roller, 1" to 3" wide.
Installation Tools	Notes
Flexible Scale or Tape Measure	
Masking Tape	1-2" wide
Clean Lint-free Cloths	
Non intrusive Infrared Temp Probe/Gun	
Heat Source	
Special Chemicals	Notes
Cleaner	3M™ Prep Solvent-70

NOTE: Part number of this accessory may not be the same as the part number shown.

General Applicability

Body Side Molding can be installed on all Corolla Models
--

Recommended Sequence of Application





Item #	Accessory
1	Body Side Molding – Can be installed in any sequence with other accessories

*Mandatory

Vehicle Service Parts (may be required for reassembly)

Item #	Quantity Reqd.	Description

Legend

	STOP: Damage to the vehicle may occur. Do not proceed until process has been complied with.
	OPERATOR SAFETY: Use caution to avoid risk of injury.
	CAUTION: A process that must be carefully observed in order to reduce the risk of damage to the accessory/vehicle and to ensure a quality installation.
	TOOLS & EQUIPMENT: Used in Figures calls out the specific tools and equipment recommended for this process.

Care must be taken when installing this accessory to ensure damage does not occur to the vehicle. The installation of this accessory should follow approved guidelines to ensure a quality installation.

These guidelines can be found in the "Accessory Installation Practices" document.

This document covers such items as:-

- Vehicle Protection (use of covers and blankets, cleaning chemicals, etc.).
- Safety (eye protection, rechecking torque procedure, etc.).
- Vehicle Disassembly/Reassembly (panel removal, part storage, etc.).
- Electrical Component Disassembly/Reassembly (battery disconnection, connector removal, etc.).

Please see your Toyota dealer for a copy of this document.

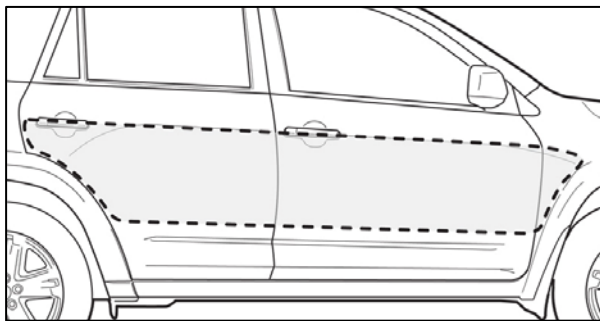

Fig 1-1

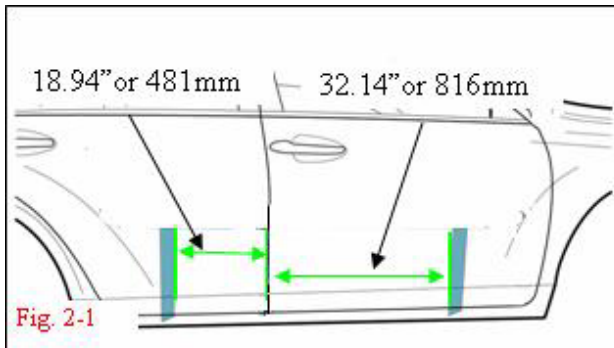

Fig. 2-1

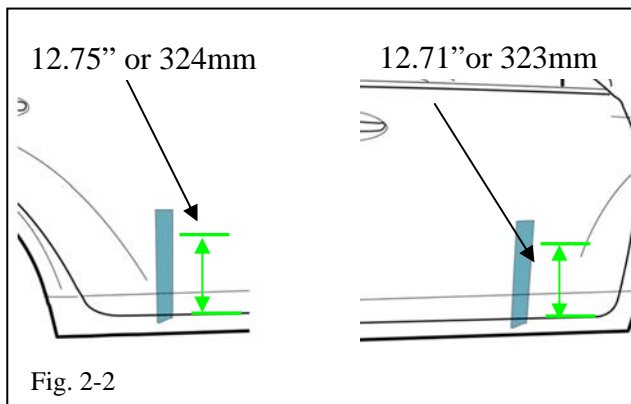





Fig. 2-2

Rear Front

1. Vehicle Preparation

-  (a) Before working on the vehicle, protect the seats and carpets with covers.
-  (b) The work area, Body Side Moldings, and vehicle door surface temperatures must be at least 60°F.
- (c) Saturate a clean lint-free cloth with 3M™ Prep Solvent-70 and clean the areas of each door as shown in Fig. 1-1.
-  (1) When cleaning with 3M™ Prep Solvent-70 follow the manufacturer's directions. Do not allow cleaner to air dry.
- (d) Wipe the cleaned surfaces with a clean, dry, lint-free cloth.
-  (e) NOTE: Once cleaned do not contaminate this surface by touching it with your bare hands.

2. Alignment Tape Application

- (a) Place a vertical piece of tape at the front of the Front Door and the rear of the Rear Door on both sides of the vehicle as shown in Fig. 2-1.
- (b) Mark the tape 12.71" (323mm) up at the front and 12.75" (324mm) at the rear. See Fig. 2-2.

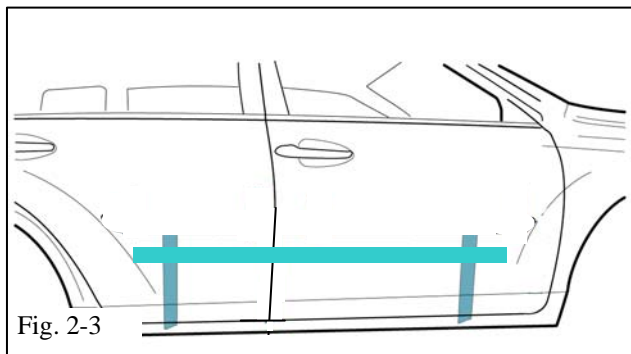

(c) Apply a horizontal strip of tape along the length of the doors as shown in Fig. 2-3. Make certain the bottom edge of this horizontal strip of tape is aligned with the marks on the vertical strips of tape and that the tape is straight and doesn't sag in the center.

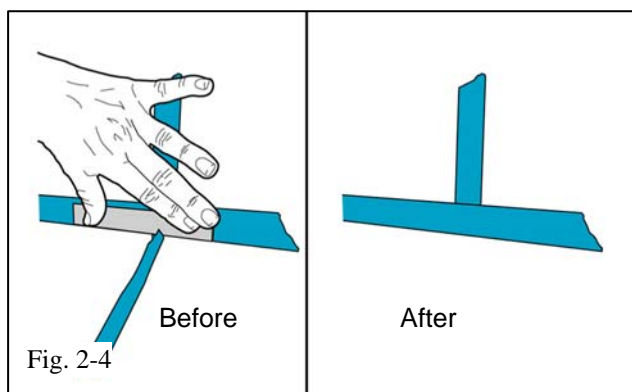

(d) Using a straight edge, tear the vertical tape sections flush with the bottom of the horizontal tape strips as shown in Fig. 2-4.

3. Body Side Molding Installation.





(a) Start with the LH Rear Door Molding. Each of the 4 Moldings is identified as to the correct position on the vehicle. While carefully holding the Molding by its edges, pull the plastic tape at the end of the part to remove the orange release line from the black acrylic foam tape strips. (Fig. 3-1)

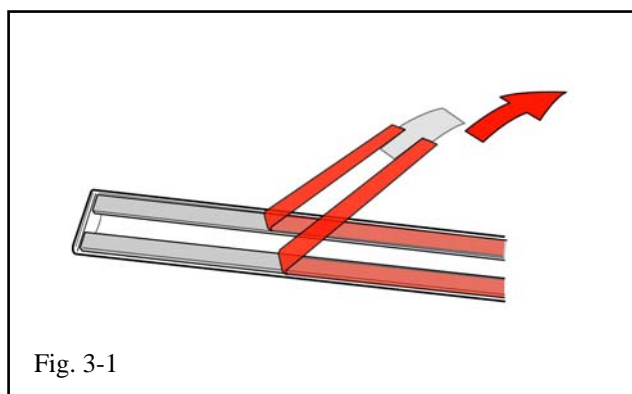

NOTE: Once the release liner is removed from the Molding, the surface of the foam tape must not be touched!

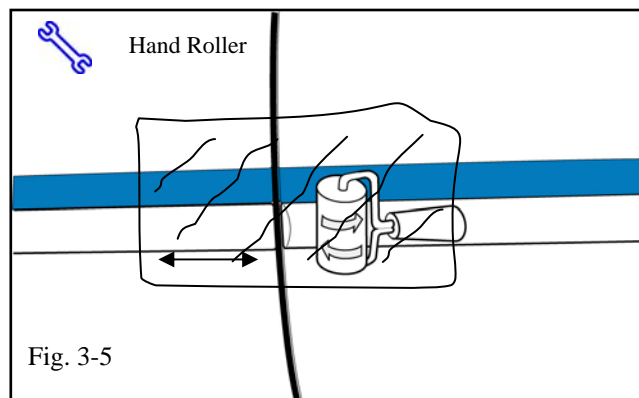
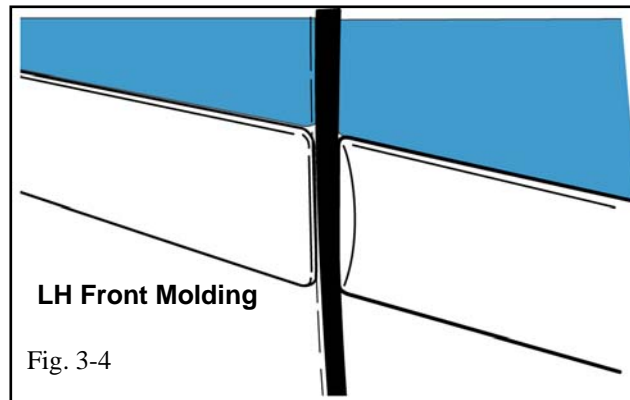
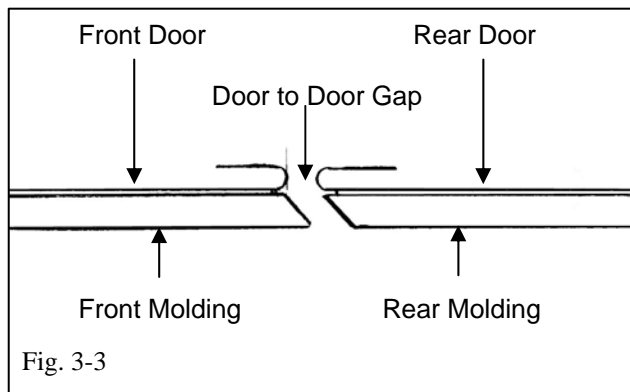
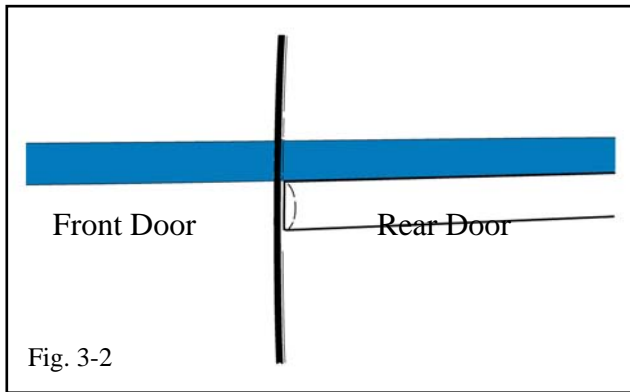



 (b) Hold the Molding about 1/2" from the surface of the rear door and align the front edge with the front edge of the rear door as shown in Fig. 3-2 & Fig. 3-3. The top edge of the molding is aligned vertically with the bottom edge of the horizontal tape strip. Once the Molding is properly aligned, press it to the door surface starting at the front and working toward the back with a rolling motion keeping the top edge aligned with the tape edge. Do not allow both ends to contact and stick to the door before the center contacts. Place the edge of the molding 2mm from the Front edge of rear the door.

(c) Repeat steps 3-a and 3-b for the LH Front Door Molding as shown in Fig. 3-3 and Fig. 3-4.

 (d) Using the hand roller and clean rag, roll around the perimeter of the parts with firm pressure to ensure complete adhesion of the tape to the door surface. Use the rag to protect the sheet metal and the molding. (Fig. 3-5)

(e) Remove and discard the tape strips.

(f) Repeat the entire installation procedure for the other side of the vehicle.

Checklist - these points **MUST** be checked to ensure a quality installation.

Check:

Look For:

Accessory Function Checks

Check visual alignment

The Moldings should be visually straight.

The front edge of the Rear Moldings should be flush with the front edge of the rear doors.

The inside rear edge of the Front Moldings should be flush with the rear edge of the front doors.

Check for proper tape adhesion.

A gap of approximately 1/2 mm is designed to exist between the edges of the Moldings and the vehicle door surfaces.

No gap is allowed between the tape and the vehicle door surfaces.

Vehicle Function Checks

None Required