

Part Number: PT278-35075

NOTE: Part number of this accessory may not be the same as the part number shown.

Kit Contents

Item #	Quantity Reqd.	Description
1	1	2 pack Mini Tie-Downs

Hardware Bag Contents

Item #	Quantity Reqd.	Description

Additional Items Required For Installation

Item #	Quantity Reqd.	Description
1		
2		
3		

Conflicts

Vehicles without bed rails

Recommended Tools

Personal & Vehicle Protection	Notes
Special Tools	Notes
Installation Tools	Notes
Special Chemicals	Notes

General Applicability

All vehicles equipped with bed rail system
--

Recommended Sequence of Application





Item #	Accessory

*Mandatory

Vehicle Service Parts (may be required for reassembly)

Item #	Quantity Reqd.	Description
1		
2		
3		
4		
5		
6		

Legend

	STOP: Damage to the vehicle may occur. Do not proceed until process has been complied with.
	OPERATOR SAFETY: Use caution to avoid risk of injury.
	CAUTION: A process that must be carefully observed in order to reduce the risk of damage to the accessory/vehicle and to ensure a quality installation.
	TOOLS & EQUIPMENT: Used in Figures calls out the specific tools and equipment recommended for this process.
	REVISION MARK: This mark highlights a change in installation with respect to previous issue.

Care must be taken when installing this accessory to ensure damage does not occur to the vehicle. The installation of this accessory should follow approved guidelines to ensure a quality installation.

These guidelines can be found in the "Accessory Installation Practices" document.

This document covers such items as:-

- Vehicle Protection (use of covers and blankets, cleaning chemicals, etc.).
- Safety (eye protection, rechecking torque procedure, etc.).
- Vehicle Disassembly/Reassembly (panel removal, part storage, etc.).
- Electrical Component Disassembly/Reassembly (battery disconnection, connector removal, etc.).

Please see your Toyota dealer for a copy of this document.

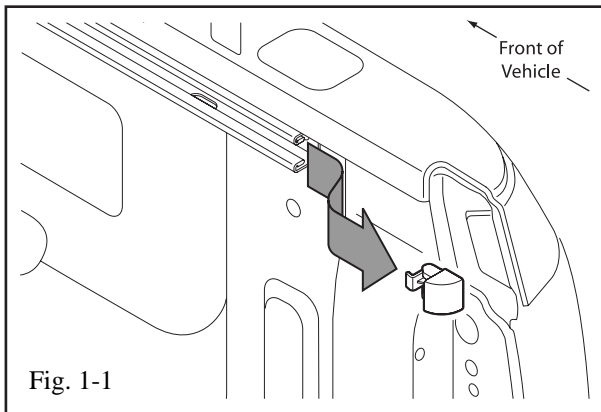

1. Install Mini Tie-Downs.

- ⚠ (a) Remove (DO NOT DISCARD) end caps from side rails by lifting the locking tab and sliding the end caps out. (Fig. 1-1)

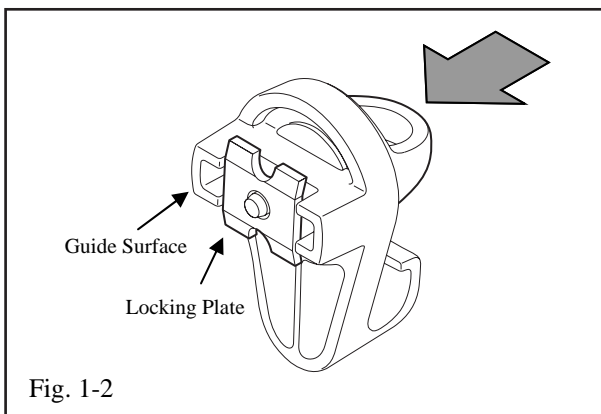

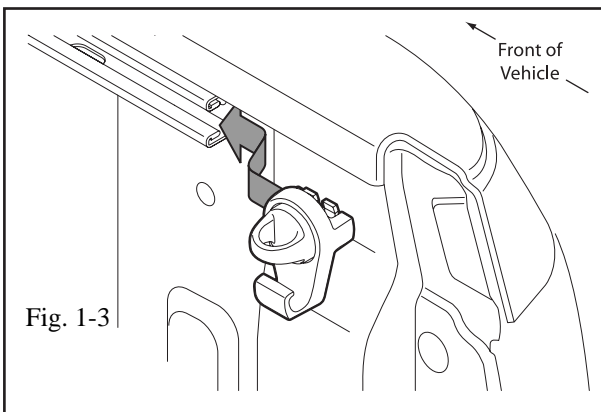

- ⚠ (b) Depress tie-down loop so that the locking plate is equal with the guide surface. (Fig. 1-2)



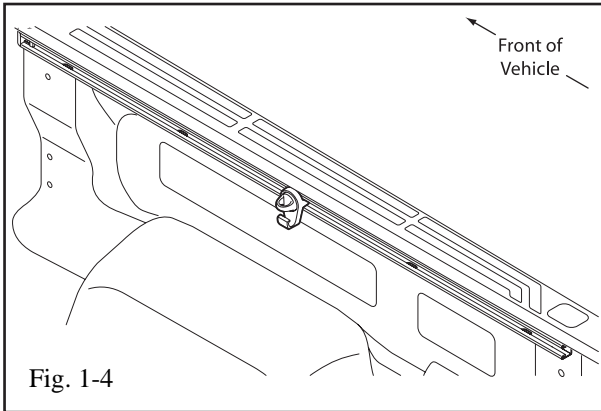

- ⚠ (c) With the tie-down loop depressed, slide the mini tie-down into the rail with the hook facing down. Release the tie-down loop when the locking plate enters the rail. (Fig. 1-3)

Note: Tie-down must be positioned between the rail and the bed post.

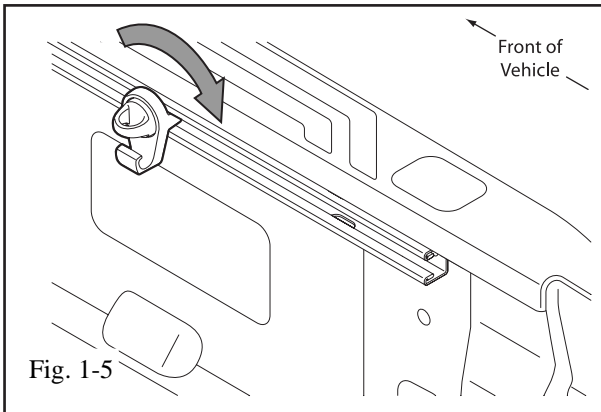

 (d) Slide mini tie-down to the nearest detent position and snap into place. To move to another detent position, depress the tie-down loop to slide to next detent. (Fig. 1-4)



 (e) Tighten tie-down loop in a clockwise direction until tight. (Fig. 1-5)

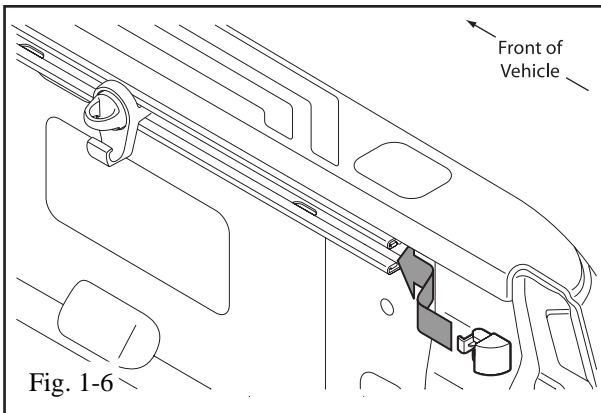

 (f) Re-install end caps (RH & LH). (Fig. 1-6)

TOYOTA TUNDRA 2007 - MINI TIE-DOWN

Checklist - these points **MUST** be checked to ensure a quality installation.

Check:

Look For:

Accessory Function Checks

- Ensure mini tie-down are locked into detents with hook facing down.

Mini tie-downs are secured on the rails.

Vehicle Function Checks

- None Required