

Part Number: 08460-21810
(Silver/Dark Gray)

NOTE: Part number of this accessory may not be the same as the part number shown.

Kit Contents

Item #	Quantity Reqd.	Description
1	1	Steering Wheel
2	1	Installation Manual
3	1	Owner's Manual

Hardware Bag Contents

Item #	Quantity Reqd.	Description

Additional Items Required For Installation

Item #	Quantity Reqd.	Description

Conflicts

Note:

Recommended Tools

Safety Tools	
Vehicle Protection	Blanket/tape, Protective Sheet
Special Tools	
Universal Puller Set "C"	Toyota SST P/N: 09950-50013
Components used from Universal Set "C": -	
Hanger 150	Toyota SST P/N: 09951-05010
Slide Arm (X2)	Toyota SST P/N: 09952-05010
Center Bolt 150	Toyota SST P/N: 09953-05020
Claw No.2 (X2)	Toyota SST P/N: 09954-05021
Installation Tools	
Screwdriver	Phillips #2
Screwdriver	Small Flathead
Ratchet	
Spinner Handle	
Extension	100 mm, 150 mm
Torx Socket	T30
Socket	19 mm
Wrench	19 mm, 10 mm
Wrench	Adjustable
Torque Wrench	
Special Chemicals	
Grease	General Purpose

General Applicability

Scion tC vehicles.

Recommended Sequence of Application





Item #	Accessory	
1		
2		

*Mandatory

Vehicle Service Parts (may be required for reassembly)

Item #	Quantity Reqd.	Description
1		
2		
3		

Legend

	STOP: Damage to the vehicle may occur. Do not proceed until process has been complied with.
	OPERATOR SAFETY: Use caution to avoid risk of injury.
	CAUTION: A process that must be carefully observed in order to reduce the risk of damage to the accessory/vehicle and to ensure a quality installation.
	TOOLS & EQUIPMENT: Used in Figures calls out the specific tools and equipment recommended for this process.

Care must be taken when installing this accessory to ensure damage does not occur to the vehicle. The installation of this accessory should follow approved guidelines to ensure a quality installation.

These guidelines can be found in the "Accessory Installation Practices" document.

This document covers such items as:-

- Vehicle Protection (use of covers and blankets, cleaning chemicals, etc.).
- Safety (eye protection, rechecking torque procedure, etc.).
- Vehicle Disassembly/Reassembly (panel removal, part storage, etc.).
- Electrical Component Disassembly/Reassembly (battery disconnection, connector removal, etc.).

Please see your Toyota dealer for a copy of this document.

1. Steering Wheel Alignment.

(a) When parking vehicle to install leather steering wheel, position vehicle so the front wheels are straight and the steering wheel is centered.

(1) Turn the steering wheel to its straight position.

(2) Apply masking tape on the top center of the steering wheel and steering column upper cover. (Fig. 1-1)

(3) Draw a line on the masking tape as shown in the illustration. (Fig. 1-1)

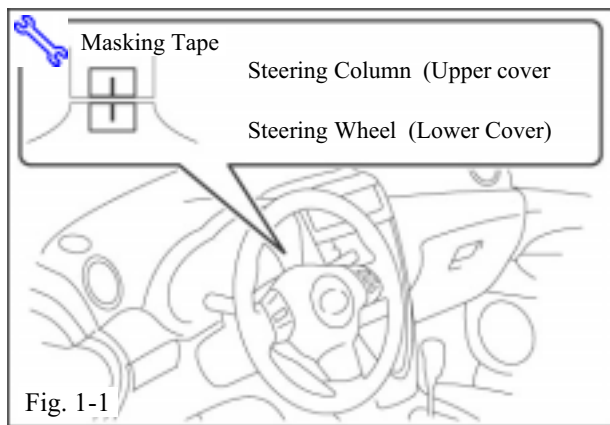

Fig. 1-1

2. Remove Battery Cable.

STOP (a) Remove the negative battery cable. (Fig. 2-1)

(1) Protect the fender before starting.

+ (2) Do not touch the positive terminal with any tool when removing cable.

+ (b) SRS Airbag System backup power is active for 90 seconds after the negative cable is disconnected from terminal.

Wait a minimum of 90 seconds after the vehicle battery is disconnected before beginning Step 3. (for air bag safety).

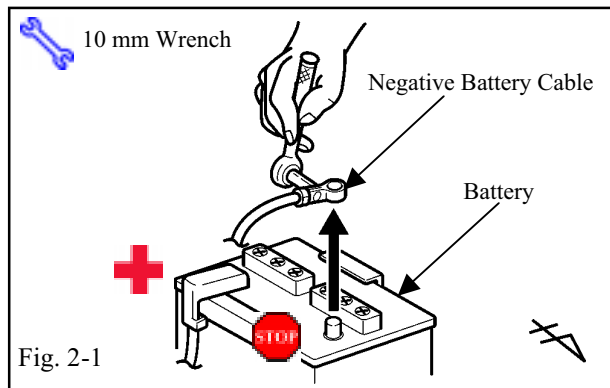
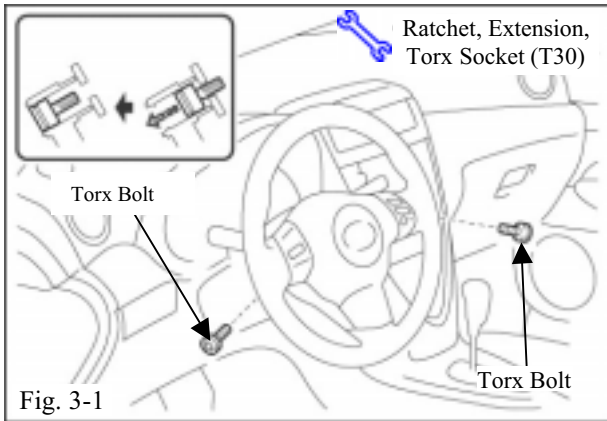

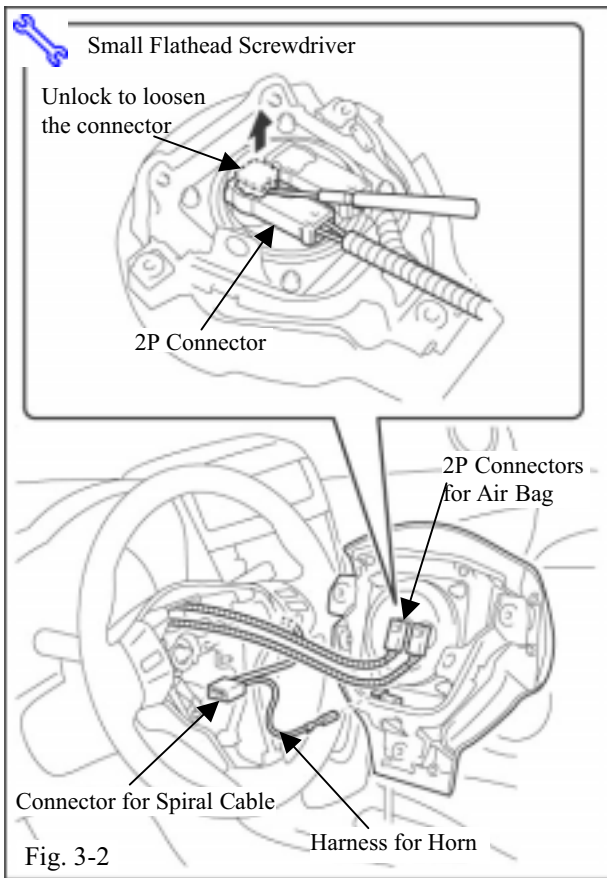



Fig. 2-1



3. Remove the Steering Pad

- (a) Loosen the two (2) Torx bolts until they are loose enough to turn freely by hand. (Fig. 3-1)
- (b) Remove the Torx bolts and retain.
-  (c) Pull the steering pad assembly straight off.



- (d) Unlock the connectors for airbag, which are on the back of the steering pad assembly, with a small flathead screwdriver and remove. (Fig. 3-2)
- (e) Remove connector from spiral cable.
- (f) Remove the horn wire/connector from the steering pad assembly.
-  (g) Set aside the steering pad assembly away from direct sunlight/heat/moisture, with the emblem always facing up.

4. Remove Steering Wheel Assembly.

- (a) Make sure the steering wheel is centered and the front wheels are in the straight-ahead position.

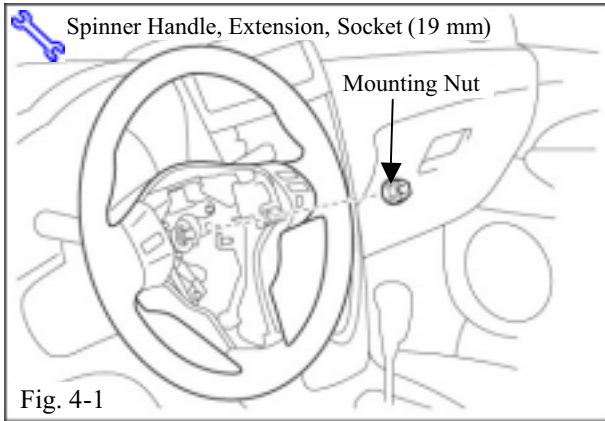

(b) Remove the steering wheel mounting nut and retain. (Fig. 4-1)



(c) Apply grease to the tip of the center bolt (09953-05020) of special tool.



NOTE: Must use the special tools to prevent potential damage.

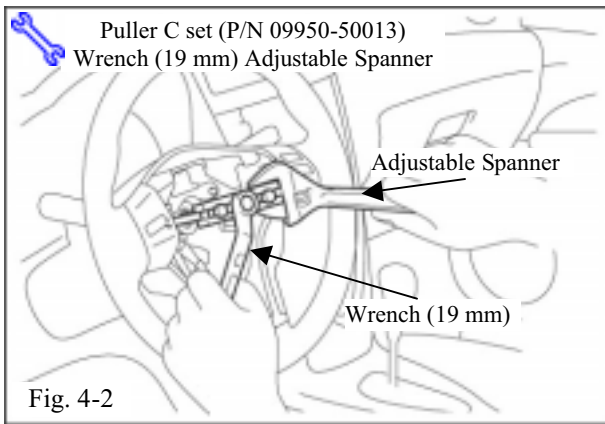

(d) Using the special tool, remove the steering wheel assembly. (Fig. 4-2)

5. Remove Cruise Control Switch. (If equipped)

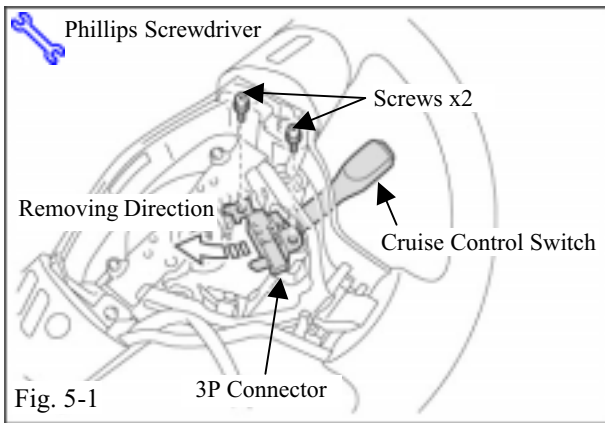

(a) Disconnect 3P connector of the cruise control switch.

(b) Loosen the two screws and remove the cruise control switch, following the direction indicated by the arrow in the figure. (Fig. 5-1).



(1) Use caution not scratch the design face with the stalk of the switch when removing it.

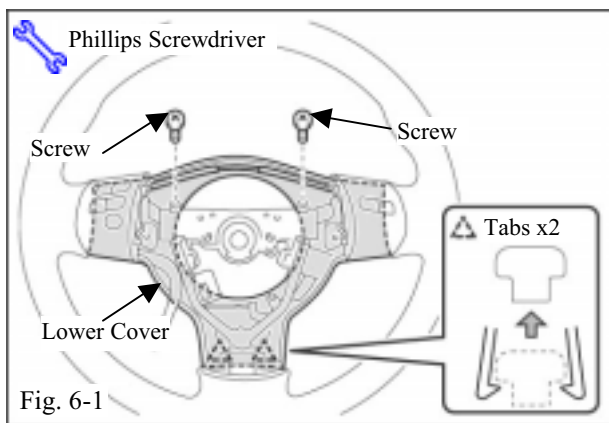

6. Remove Lower Cover.

- (a) Loosen and remove the two tapping screws and unsnap two tabs to remove the lower cover. (Fig. 6-1).



- (1) Be sure not to damage the lower cover when removing the parts by unsnapping the tabs.

7. Install Lower Cover to Leather Steering Wheel.

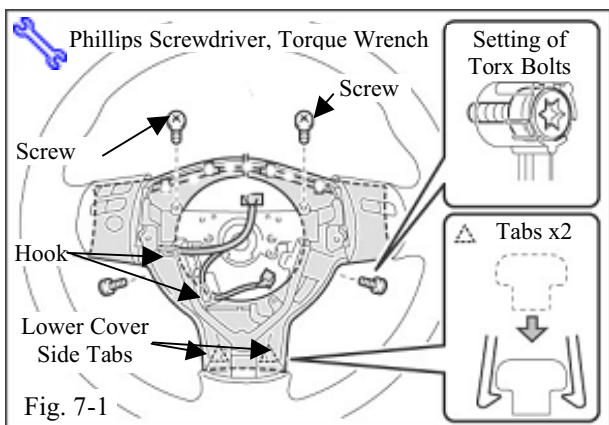

- (a) Set the two Torx bolts on the lower cover. (Fig. 7-1).
- (b) Fix the lower cover to the leather steering wheel assembly with the two tapping screws.



- (1) Tighten screws to 0.8 N-m (0.6 lbf-ft)



- (2) Be sure not damage the lower cover when installing the parts by opening the tabs.

**8. Install Cruise Control Switch.
(If equipped)**

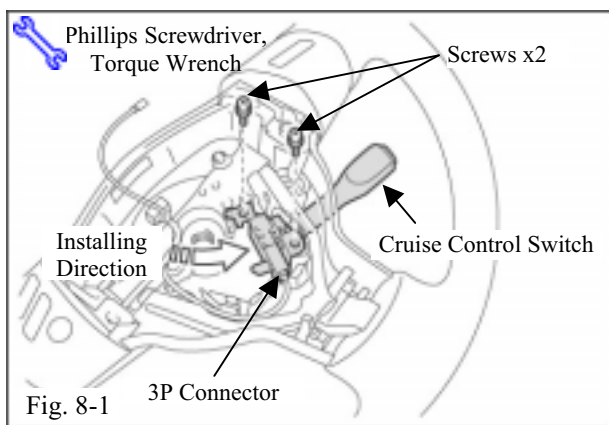

- (a) Install the cruise control switch, following the arrow and fix it with the two screws. (Fig. 8-1).



- (1) Tighten screws to 1.7 N-m (1.3 lbf-ft)

- (b) Connect 3P connector of the cruise control. (If equipped)



- (1) Be cautious not to scratch the design face with the the stalk of the switch when installing it.

- (2) Make sure that harness of the cruise control switch assembly does not interfere with moving section or is not caught in the section.

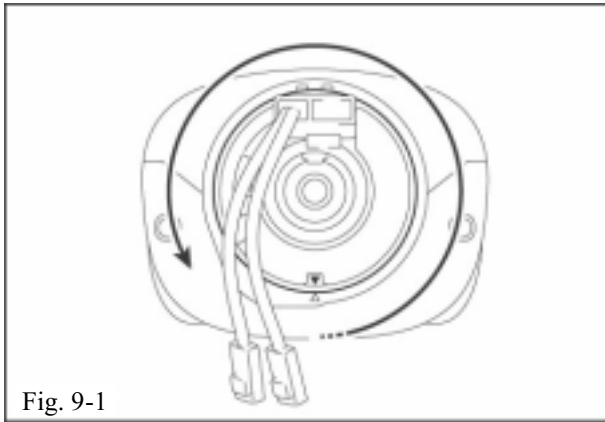

Fig. 9-1

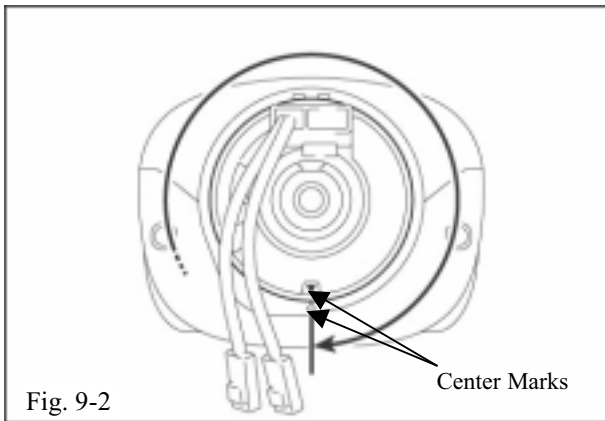

Fig. 9-2

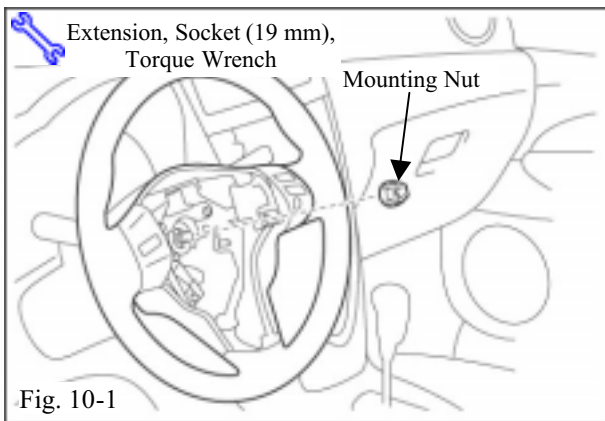

Fig. 10-1

9. Center Spiral Cable.

- (a) Confirm that the front wheels are straight.
- (b) Carefully turn the spiral cable counterclockwise all the way until it will no longer turn. (Fig. 9-1)

- (c) From there, turn back the spiral cable 2.5-turns clockwise and get the center marks aligned as shown in the diagram. (Fig. 9-2)

10. Install Leather Bound Steering Wheel Assembly.

NOTE: Install and hand tighten the mounting nut, and then turn the steering wheel left or right until it is locked. Unlock the steering wheel lock after this operation.

- (a) Holding the leather bound steering wheel assembly horizontally in T form, assemble the steering wheel assembly onto the steering column shaft. (Fig. 10-1)



- (1) Ensure that the marked lines (Step 1. A. iii.) on the masking tape are lined up.



- (b) Fasten the leather bound steering wheel assembly to the steering column shaft with the previously removed nut.

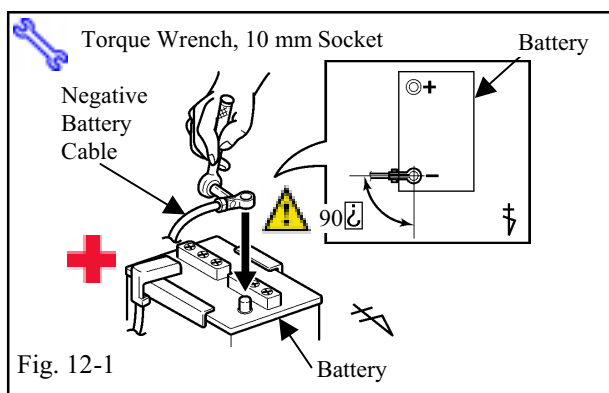
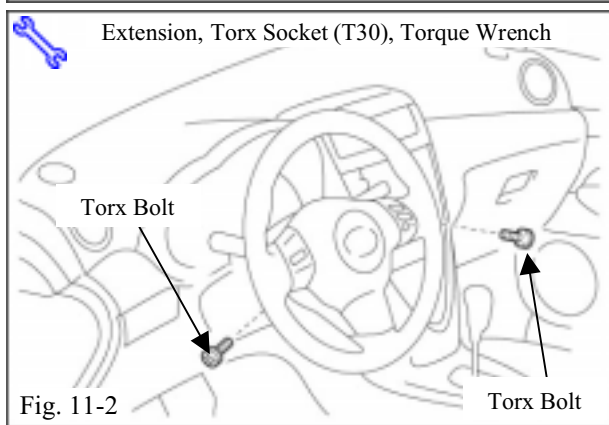
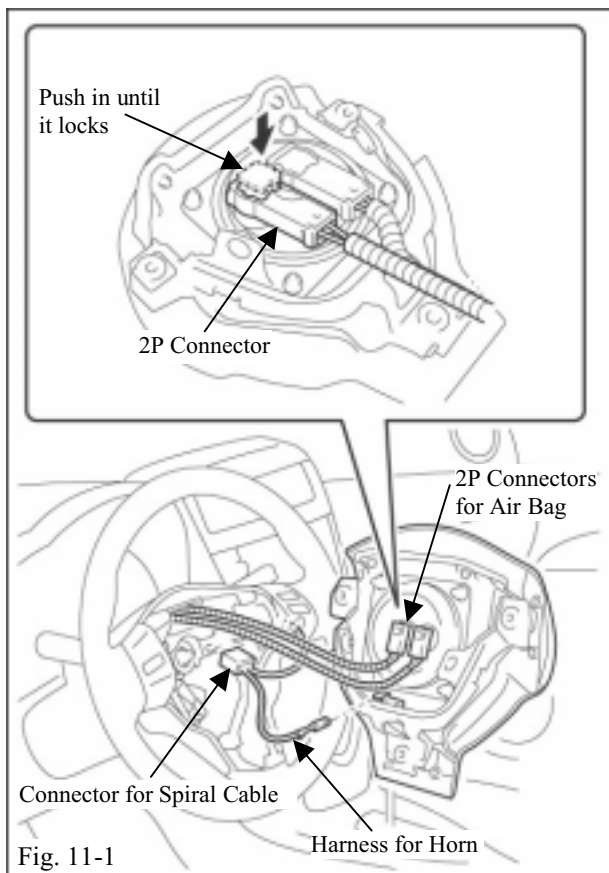

- (1) Tighten nut to 50.0 N-m (37 lbf-ft)



11. Install Steering Pad Assembly.

-  (a) Mount the connectors for airbag on the back of steering pad assembly, fasten the lock and fix in position. (Fig. 11-1)
-  (b) Connect the horn wire/connector to the steering pad assembly.
-  (c) Reconnect connector to spiral cable.
- (d) Mount the steering pad assembly on the leather bound steering wheel assembly.

- (e) Fix the steering pad assembly on the leather bound steering wheel assembly by tightening the two Torx bolts. (Fig. 11-2)

-  (1) Tighten bolts to 8.8 N-m (6.5 lbf-ft)

12. Reconnect Negative Battery Cable.

- (a) Reconnect the vehicle's negative battery cable.

- (1) Position the negative terminal at an angle of ~90 deg. to the battery as shown. (Fig. 12-1)

-  (2) Tighten the nut to 4.1 N-m (36 lbf-in).

-  (3) Do not touch the positive terminal with any tool when replacing the cable.

- (b) Reset the power windows.
 - (1) Turn ignition key to ON position.
 - (2) Push down the power window switches of each door, and lower the windows halfway.
 - (3) Pull up the switches until the windows close and hold switches up for a further one (1) second (minimum.)
- (c) Reset the power moon roof.
 - (1) Push and hold moon roof switch to close side until moon roof closes. Hold for a further 2 seconds.

13. Adjust Steering Wheel Angle.

- (a) Perform a driving test.
- (b) Inspect steering wheel off center.
 - (1) Drive the vehicle in a straight line for 100 meters at a constant speed of 35 mph (56 km/h), and hold the steering wheel to maintain the course.
 - (2) Turn the steering wheel to its straight ahead position.
 - (3) Draw a new line on the masking tape of the steering wheel as shown in the illustration. (Fig. 13-1)
 - (4) Measure the distance between the two (2) lines on the masking tape of the steering wheel. This distance should be "0".
 - (5) Convert the measured distance to steering angle.
Measured distance 1 mm (0.04 in.) =
Steering angle approximately 1 deg.

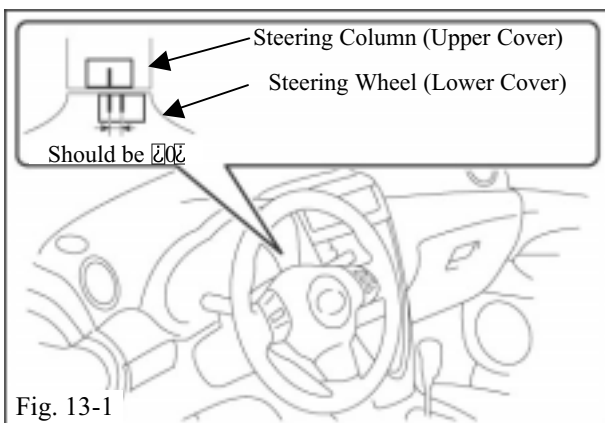
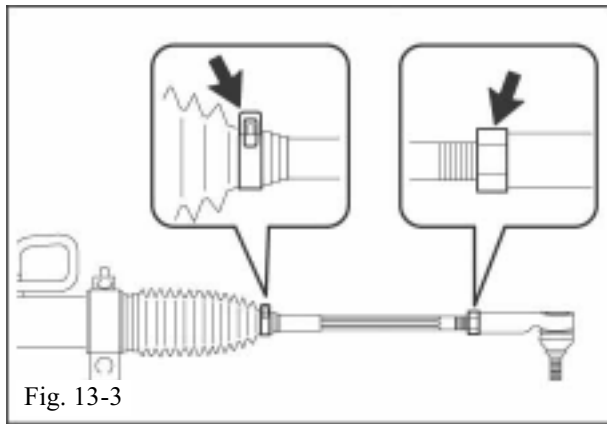
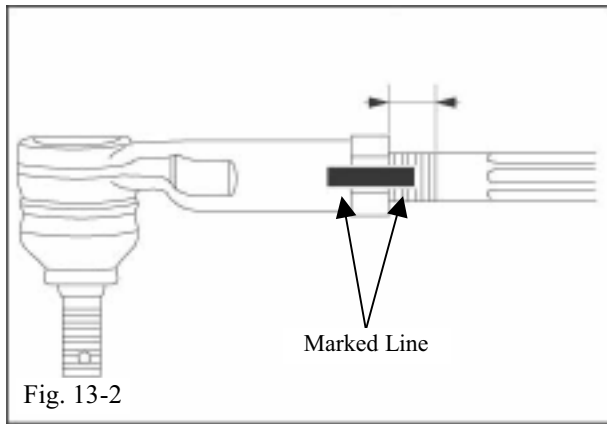

Fig. 13-1

NOTE: Note the steering wheel angle.



(c) If angle deviates from the centerline position, adjust angle using the following procedure.

(d) Draw line on the RH and LH tie rods and rack ends where it can easily be seen. (Fig. 13-2)

(e) Use a paper gauge, measure distance from RH and LH tie rod ends to rack end screw thread. Note the measured values.

(f) Remove the RH and LH boot clips from the rack boots. (Fig. 13-3)

(g) Loosen the RH and LH lock nuts.

(h) Turn the RH and LH rack and by the same amount (but in different directions) according to the steering wheel angle.

NOTE: One (1) turn 360 deg. of rack end (1.5 mm (0.059 in.) horizontal movement) = 12 deg. of steering angle.

(i) Tighten the RH and LH lock nuts.



(1) Make sure that the difference in length between RH and LH tie rod ends and rack end screws are within 1.5 mm (0.059 in.).



(2) Tighten lock nuts to 47.0 N-m (35 lbf-ft).

(j) Re-install the RH and LH boot clips.

Checklist - these points **MUST** be checked to ensure a quality installation.

Check:

- Negative battery terminal for tightness
- Horn
- SRS warning light - turn ignition key ON

- Cruise control switch

- Steering wheel angle

Look For:

Terminal should be tight.

Verify that the horn works.

Verify that SRS warning light comes ON and then goes OFF (after ~ 5 to 6 seconds). If SRS Warning Light remains on or flashes, or does not illuminate at all - take corrective measures as required in accordance with the service manual troubleshooting chart.

Verify that the switch functions correctly. If switch does not function correctly, troubleshoot as required in accordance with the service repair manual.

Steering wheel is straight.