

**Part Number: 08446-12800**  
**(Light Gray)**

**NOTE:** Part number of this accessory may not be the same as the part number shown.

**Kit Contents**

Item #	Quantity Reqd.	Description
1	1	Quarter Garnish Net RH
2	1	Quarter Garnish Net LH
3	8	Cap
4	8	Screw M6×35
5	1	Template(1)for Upper Right
6	1	Template(2)for Lower Right
7	1	Template(3)for Upper Left
8	1	Template(4)for Lower Left
9	1	Installation Instructions
10	1	Instruction (Owner's) Manual

**Hardware Bag Contents**

Item #	Quantity Reqd.	Description

**Additional Items Required For Installation**

Item #	Quantity Reqd.	Description

**Conflicts**

Note:

**Recommended Tools**

<b>Safety Tools</b>	
Protective Glasses	
Protective Glove	
<b>Installation Tools</b>	
Screwdriver	
Electric Drill Bit	φ4
Hole Saw Bit	φ15
Electric Drill	
Drill Stopper	φ4, φ15
Punch	
Diverging Cutter	
Masking Tape	
Vinyl Sheet	

**General Applicability**

All vehicles

**Recommended Sequence of Application**

Item #	Accessory	
1		
2		

\*Mandatory

**Vehicle Service Parts** (may be required for reassembly)

Item #	Quantity Reqd.	Description
1		
2		
3		

**Legend**

 **STOP:** Damage to the vehicle may occur. Do not proceed until process has been complied with.

 **OPERATOR SAFETY:** Use caution to avoid risk of injury.

 **CAUTION:** A process that must be carefully observed in order to reduce the risk of damage to the accessory/vehicle and to ensure a quality installation.

 **TOOLS & EQUIPMENT:** Used in Figures calls out the specific tools and equipment recommended for this process.

## Installation Overview

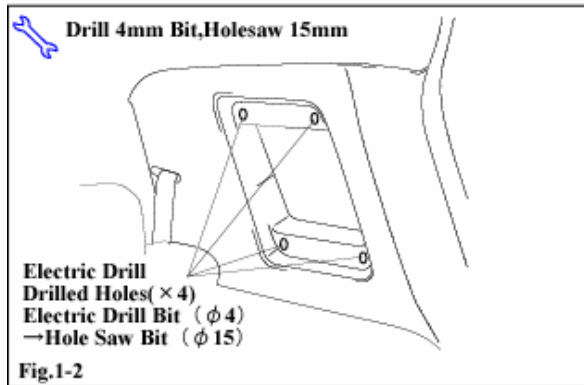
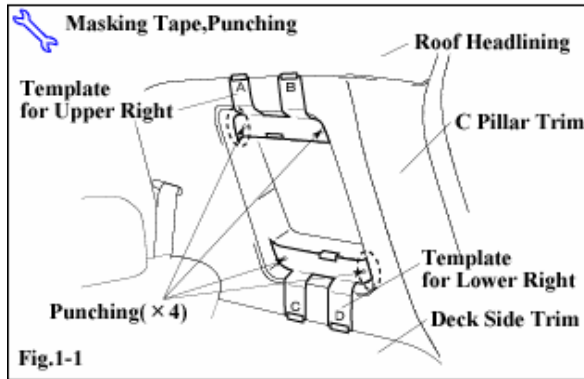

### 1. INSTALL QUARTER GARNISH NET RH

- (a) Align the template for upper right (indicated by A/B) with the boundary line between the C pillar trim and the roof headlining. Fit it into the recessed section of the C pillar trim along the area marked with the dashed line and secure it in place using masking tape as shown. (Fig.1-1)
- (b) Align the template for lower right (indicated by C/D) with the boundary line between the C pillar trim and the deck side trim. Fit it into the recessed section of the C pillar trim along the area marked with the dashed line and secure it in place using masking tape as shown. Then mark the four screw positions on the two paper templates using a punch. (Fig.1-1)
- (c) Remove the two paper templates. Drill a 4 mm pilot hole first and then a 15 mm hole in the marked positions using an electric drill. Remove any burrs and chips from the drilled portions using a diverging cutter. (Fig. 1-2)

#### ⚠ NOTE:

Install a drill stopper onto the electric drill bit and hole saw bit an appropriate length away from the tip end as shown in the illustration (approximately 5mm for the drill bit, and 15mm for the hole saw).

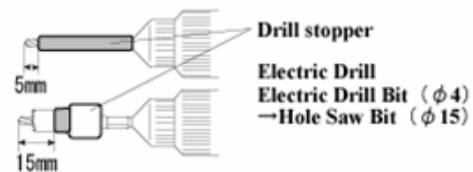

#### ⚠ NOTE:

Lay a vinyl sheet over the vehicle interior when drilling holes using an electric drill or hole saw, as burrs and chips are created. Care must be taken to prevent this debris from getting inside the C pillar trim.

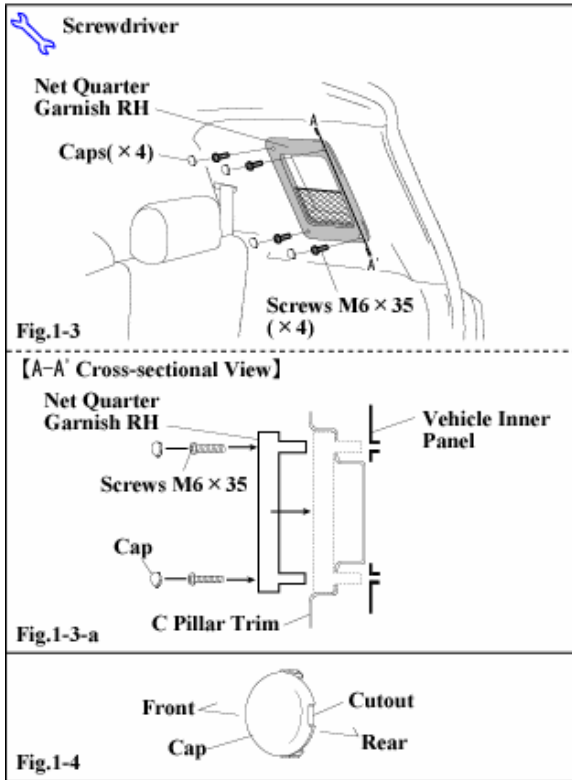

**NOTE:**  
+ Use protective gloves and protective glasses when operating the electric drill or diverging cutter to avoid injuries.

- (d) Attach the quarter garnish net RH onto the C pillar trim's pocket with the 4 screws and the weld nuts of the vehicle inner panel as shown. (Fig. 1-3)
- (e) Fit the 4 caps onto the screw heads. Make sure that the cap's cutouts are directed toward the front and rear of the vehicle. (Fig. 1-3 & 1-4)

Installation Overview

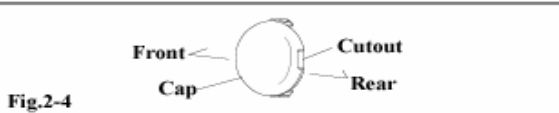
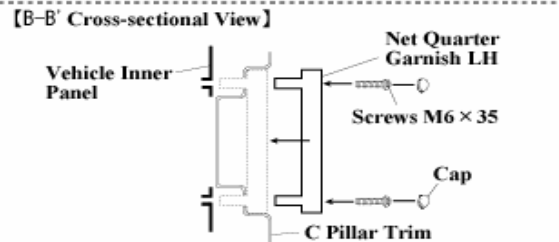
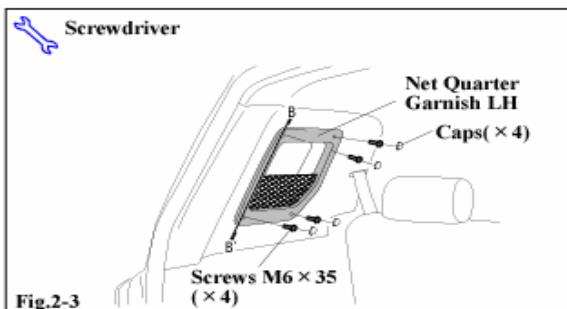
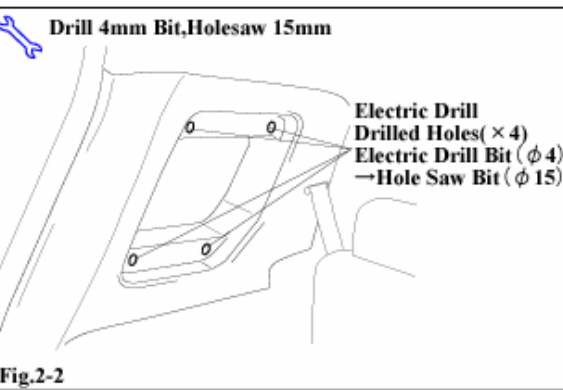
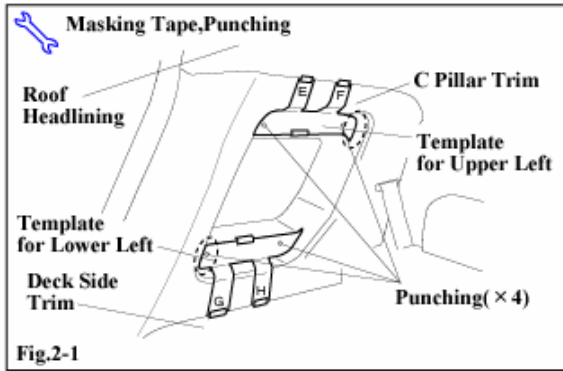

2. INSTALL QUARTER GARNISH NET LH

- (a) Align the template for the upper left (indicated by E/F) with the boundary line between the C pillar trim and the roof headlining. Fit it into the recessed section of the C pillar trim along the area marked with the dashed line and secure it in place using masking tape as shown. (Fig. 2-1)
- (b) Align the template for lower left (indicated by G/H) with the boundary line between the C pillar trim and the roof headlining. Fit it into the recessed section of the C pillar trim along the area marked with the dashed line and secure it in place using masking tape as shown. Then mark the four screw positions on the two paper templates using a punch. (Fig. 2-1)
- (c) Remove the two paper templates. Drill a 4 mm pilot hole first and then a 15 mm hole in the marked positions using an electric drill. Remove any burrs and chips from the drilled portions using a diverging cutter. (Fig. 2-2)

**NOTE:**

Install a drill stopper onto the electric drill bit and hole saw bit an appropriate length away from the tip end as shown in the illustration (approximately 5mm for the drill bit, and 15mm for the hole saw).

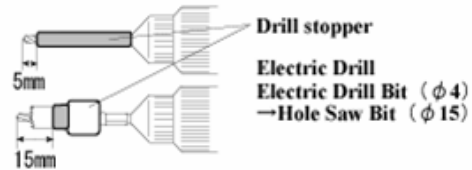

**NOTE:**

Lay a vinyl sheet over the vehicle interior when drilling holes using an electric drill or hole saw, as burrs and chips are created. Care must be taken to prevent this debris from getting inside the C pillar trim.



Use protective gloves and protective glasses when operating the electric drill or diverging cutter to avoid injuries.

- (d) Attach the quarter garnish net LH onto the C pillar trim's pocket with the 4 screws and the weld nuts of the vehicle inner panel as shown. (Fig. 2-3)
- (e) Fit the 4 caps onto the screw heads. Make sure that the cap's cutouts are directed toward the front and rear of the vehicle. (Fig. 2-3 & 2-4)
- (f) Place the instruction manual in the glove box.

Checklist - these points **MUST** be checked to ensure a quality installation.

Check:

- Vehicle interior clean
- Proper installation

Look For:

No dirt, debris from installation.

Quarter garnish net securely attached, no looseness.