



**Southeast Toyota Distributors, LLC
Accessory Installation Instructions**

2018 Tacoma LED Bed Lights

Year & Model:	2018 Tacoma
Part Number:	00016-34187; 00016-35087
Accessory Code:	BU1010, BU1020
PIO / DIO:	PIO / DIO
Business Partner:	J67

Conflicts

None

General Applicability

Fits Models	
1	2018 Models-All

Additional Items Required For Installation

Item#	Description:
1.	N/A

Sequence of Application

Item#	Accessory:
1.	N/A
<p><u>SPECIALNOTE: Installation Sequences</u> After TMS & Safety mandated preparatory steps have been taken, the installation sequence is the suggested method for completing the accessory installation. In some instances the suggested sequence is written for one associate to install & in others the sequence is given as part of a team accessory installation. Unless otherwise stated in the document, the associates may perform the installation steps in any order to make the installation as efficient as possible while maintaining consistent quality.</p>	

Recommended Tools

Safety Tools	Notes
Safety Glasses	Required
Gloves	Required
Installation Tools	Notes
Screw Gun/Drill	
Uni-bit /Drill Bit	7/16" with 2" Drill Stop
Drill Bit	7/64" with 2" Drill Stop
Ratchet	
Socket	10mm
Phillips Head Screwdriver	NO.2
Utility Knife	
Pliers	
Torque Wrench	48 in-lb
Special Chemicals	
3M Body Sealant	
Special Tools	Notes
PIO Drill Location Templates	Driver Side Part #: TA6-35087-DR Passenger Side Part #: TA6-35087-PA

Legend

	STOP: Damage to the vehicle may occur. Do not proceed until process has been complied with.
	OPERATOR SAFETY: Use caution to avoid risk of injury.
	CAUTION: A process that must be carefully observed in order to reduce the risk of damage to the accessory/vehicle and to ensure a quality installation.
	TOOLS & EQUIPMENT: Used in Figures calls out the specific tools and equipment recommended for this process.
	REVISION MARK: This mark highlights a change in installation with respect to previous issue.
	SAFETY TORQUE: This mark indicates that torque is related to safety.

Table of Contents

I. Preparation.....1-5

 a.) Table of Contents.....2

 b.) Kit/Hardware & Wire Harness Bag Contents.....3

 c.) Parts for Installation.....4

 d.) Service & Warranty Information.....5

II. Procedures

 a.) Battery Removal.....6

 b.) Vehicle Disassembly –Installation Process.....6-17

III. Re-install Battery.....17

IV. Function and Quality Check.....18

V. Diagnostic /Block Diagrams & Connectors Procedures.....13-16

VI. DIO Paper Drill Template.....19-20

VII. Warranty Statement.....21-22

Kit/Hardware Bag Contents:

Item #	Quantity	Description
1.	4	Phillips Head Stainless Steel Screws
2.	20	Wire Ties
3.	1	22-18 AWG T-Tap (Red)
4.	1	12-10 AWG T-Tap (Yellow)
5.	2	Connector Body
6.	2	Connector Retention Clips

Parts for Installation:

Care must be taken when installing this accessory to ensure damage does not occur to the vehicle. The installation of this accessory should follow approved guidelines to ensure a quality installation. These guidelines can be found in the “Accessory Installation Practices” document.

This document covers such items as:

- Vehicle Protection (use of covers and blankets, cleaning chemicals, etc.).
- Safety (eye protection, re-checking torque procedure, etc.).
- Vehicle Disassembly/ Reassembly (panel removal, part storage, etc.).
- Electrical Component Disassembly/Reassembly (battery disconnection, connector removal, etc.).

Item #	Quantity	Description
1.	1	Driver Side LED Assembly
2.	1	Passenger Side LED Assembly
3.	1	Hardware Kit
4.	1	Wire Harness

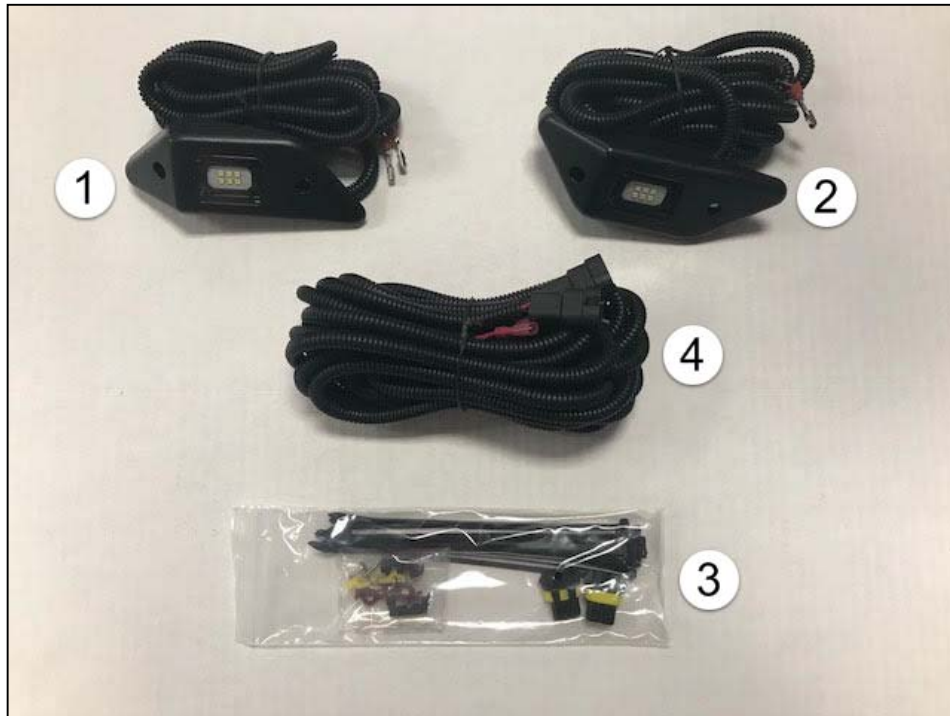

Service & Warranty Information:

Image Key	Parts information		Warranty Information	
	Part Number	Description	Warranty Time	Labor Op. Code
N/A	00016-35087, 34187	Tacoma LED Bed Lights	N/A	N/A
A	00016-35087-01; 34187	Driver Side Light	0.5	ABL011
B	00016-35087-02; 34187	Passenger Side Light	0.5	ABL011
C	00016-35087-03; 34187	Wire Harness	0.5	ABL021
D	00016-35087-04; 34187	Hardware Kit	N/A	N/A

If you are a dealer located outside of the Southeast Region, please contact the SET Accessory Warranty Department at (888) 851-2722 or email Accessory.Warranty@SEToyota.com for claim payment instructions.

Image:





Figure 1

Vehicle Disassembly and Installation

1. Remove the negative battery cable. See Figure 1.



DO NOT come in contact with the positive terminal during the removal of the negative cable.



NOTE: Wait a minimum of 90 seconds for the SRS system to power down before proceeding.



Figure 2

2. Remove driver side front threshold plate, driver side rear threshold plate (not pictured) and kick panel cover. See Figure 2.



Figure 3

3. **ACCESS CAB ONLY:** Remove the driver side lower dash panel and disengage the hood release cable. See Figure 3.

Note: Place red hang tag on instrument panel sub-assembly OR hood release cable when removing hood latch cable from hood latch release lever. See Figure 3. Red Tag required for PIO only. Tag is not part of the kit contents.



Figure 4

4. **DIO ONLY:** Cut out the paper templates located on the last two pages of this document by cutting along the dashed lines. After locating the position, use tape to secure the template as needed. See Figure 4.

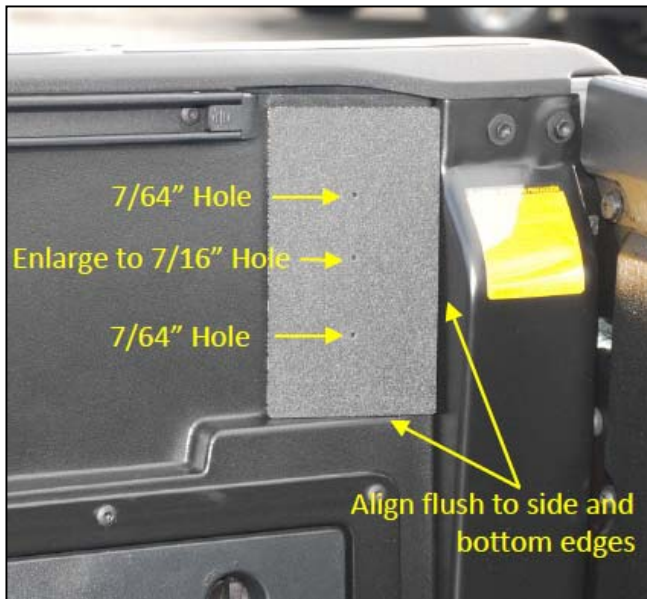

Figure 5



Figure 6

5. Use the provided templates to mark the drill locations for the bed light LED assemblies. See Figure 5.



- a. Locate and align Drill Template position near the tailgate as shown, Ensure the back and bottom edges are flush. See Figure 5.



- b. Use a 7/64" Drill bit to pre-drill all 3 holes.



- c. Use a 7/16" Drill bit with drill stop set to 2" to drill the center hole for wire harness routing.

- d. Vacuum drill shavings.

6. Route the bed light LED assembly wire harness through the 7/16" hole and mount the LED assembly using the screws provided. See Figure 6.

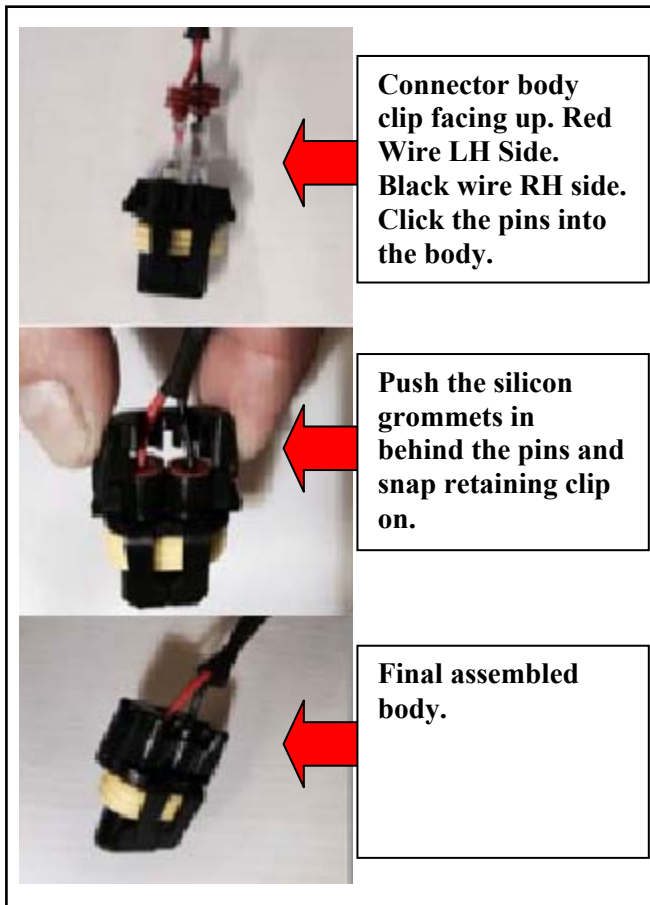

Figure 7

7. Insert the Bed Light LED assembly harness pins into the connector body & snap on the connector retaining clips. See Figure 7.

8. Route the passenger side bed light LED wire harness along the factory wire harness toward the driver side at the rear of the bed near the spare tire, split excess wire & bundle half on driver's side & half on passenger's side. See Figure 8.



Figure 8

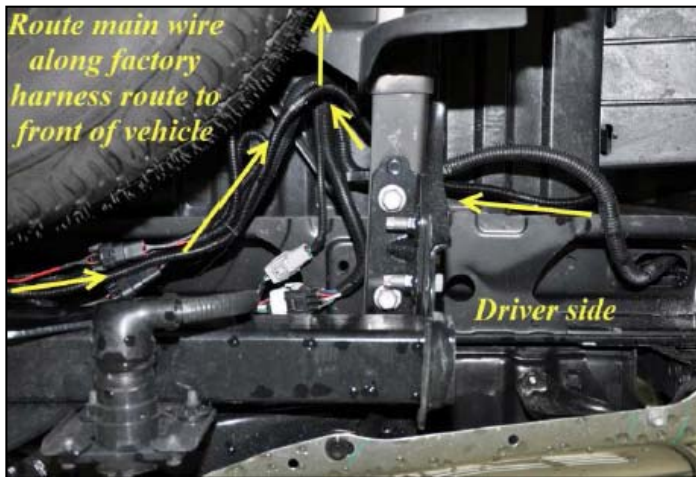

Figure 9

9. Connect the water-proof connector on the bed light LED assembly wire harness going to the cab of the vehicle in step 10. Wire tie the bed light LED harness to OE harnesses. See Figure 9.



Figure 10

10. Route the bed light LED wire harness from the spare tire area toward the cab on the driver side of the vehicle. Route along the OE wire harness using wire ties as needed. See Figure 10.



Figure 11

11. Route the wire harness past the spare tire. Attach the Bed Light LED harness to the OE factory harness using wire ties. See Figure 11.
12. Route the bed light LED wire harness along the OE factory harness and attach it using wire ties.

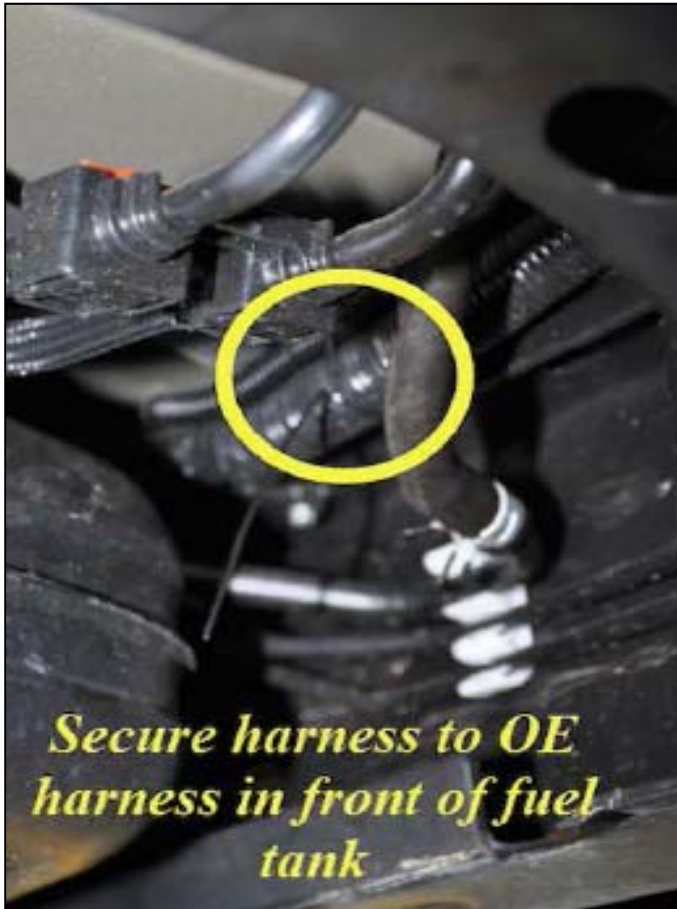

Figure 13

13. Secure the bed light LED wire harness to the OE harness in front of the fuel tank using wire ties. See Figure 13.



Figure 14

14. Lift the driver side floor carpet behind the front seat to expose the body grommet. See Figure 14.

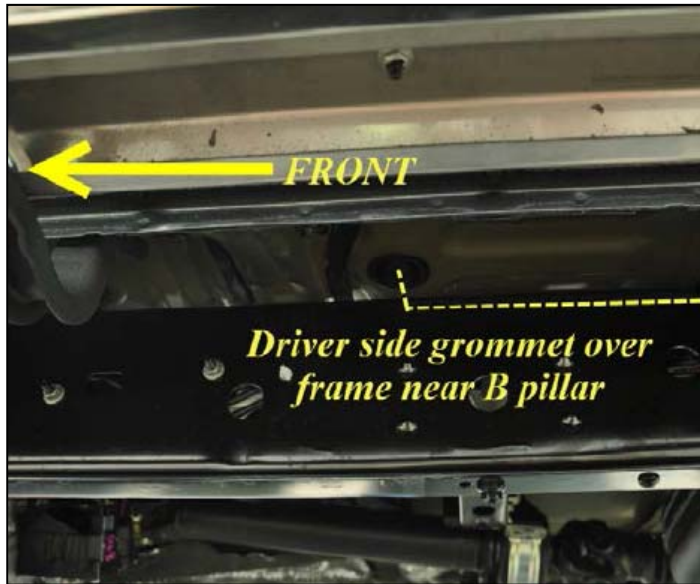

Figure 15

15. Cut a slit in the body grommet from the underside of the vehicle. See Figure 15.
 - a. Insert the Bed Light LED wire harness, red blade connector side, through the underside of the grommet.
 - b. Pull wire harness an adequate length to reach the driver side junction into the passenger compartment.
NOTE: Approx. 4-5'
 - c. Seal the Bed Light LED harness hole in the grommet with 3M Body Sealant.



Figure 16A

16. Route the wire harness from grommet to driver rear threshold plate, then forward under B-pillar kick panel, driver front threshold plate and into the driver side kick panel to the fuse panel. Secure to OE Factory harness with wire ties. See Figure 16A.



Caution: Avoid airbag harness on driver side threshold as shown in Figure 16B.



Figure 16B

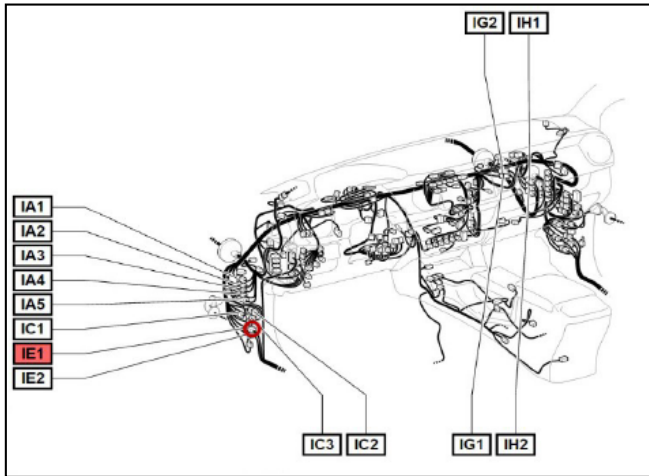

Figure 17A

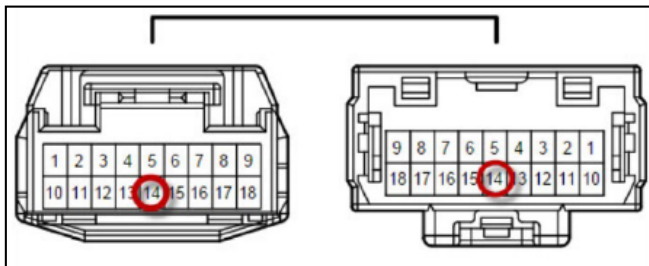

Figure 17B

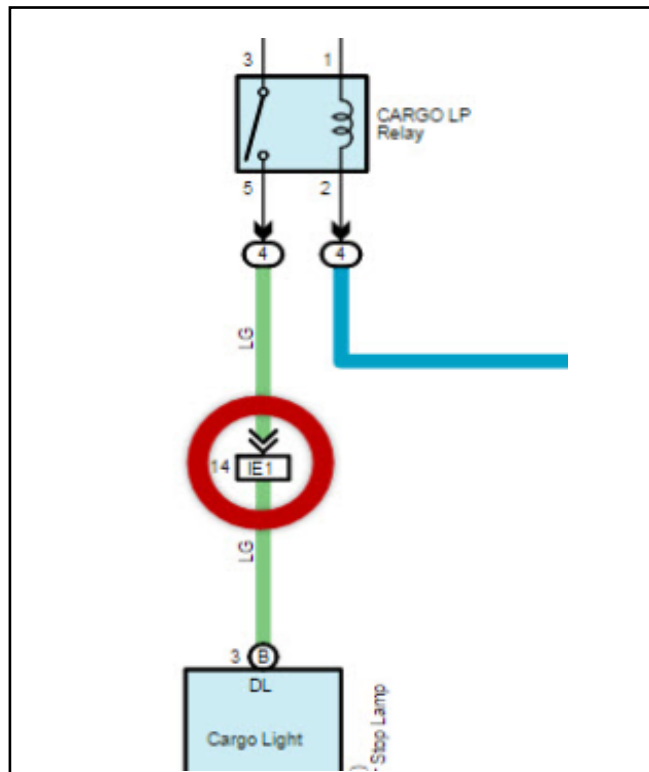

Figure 17C

17. Install T-Taps.

Double Cab Vehicle

- a. Find IE1 White connector located behind lower driver side kick panel cover. Attach a RED 22-18 AWG T-Tap to the LIGHT GREEN wire pin 14. Use pliers to ensure the T-tap is snapped in correctly. Plug the RED wire from the Bed Light LED wire harness into the T-tap. See Figures 17A, 17B, 17C, 17D, and 17E.

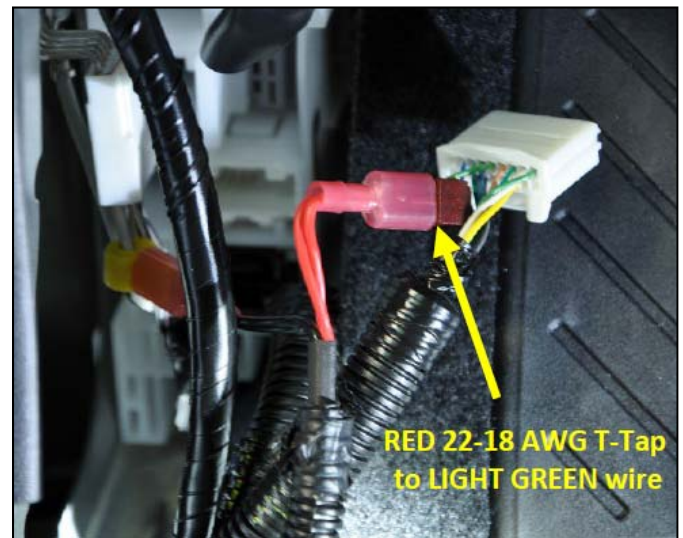

Figure 17D

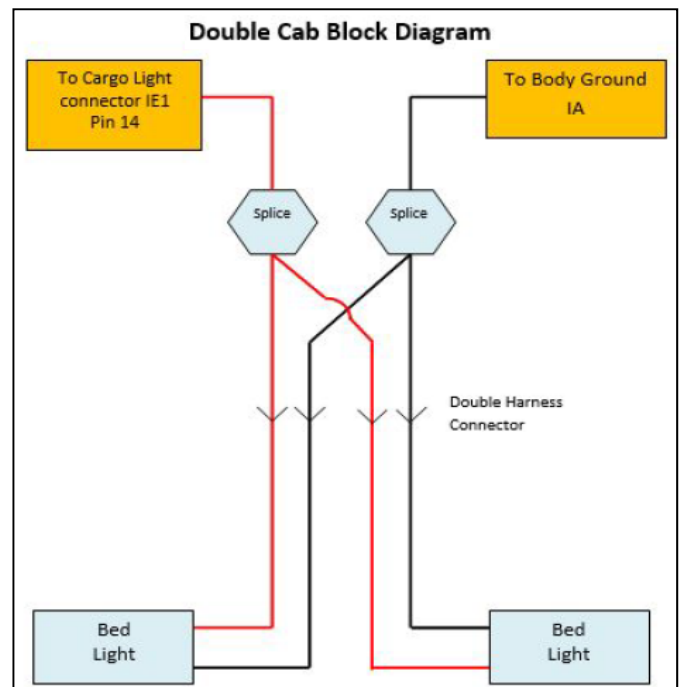

Figure 17E

- b. Find Instrument panel ground point IA on driver kick panel. Attach a YELLOW 12-10 AWG T-Tap to the factory ground point WHITE wire with BLACK TRACE on kick panel wall. Use pliers to ensure the T-Tap is snapped in correctly. Plug the BLACK wire from the Bed Light LED wire harness into the T-Tap. See Figures 17F, 17G & 17H.

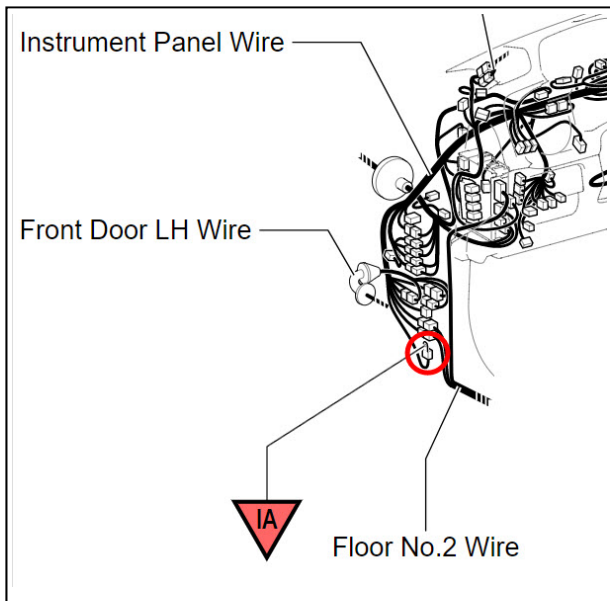

Figure 17F

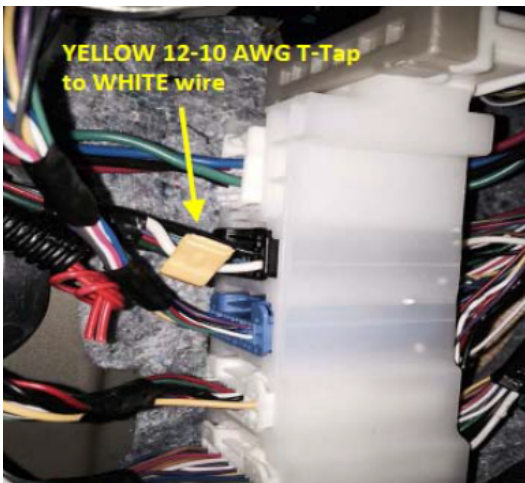

Figure 17G

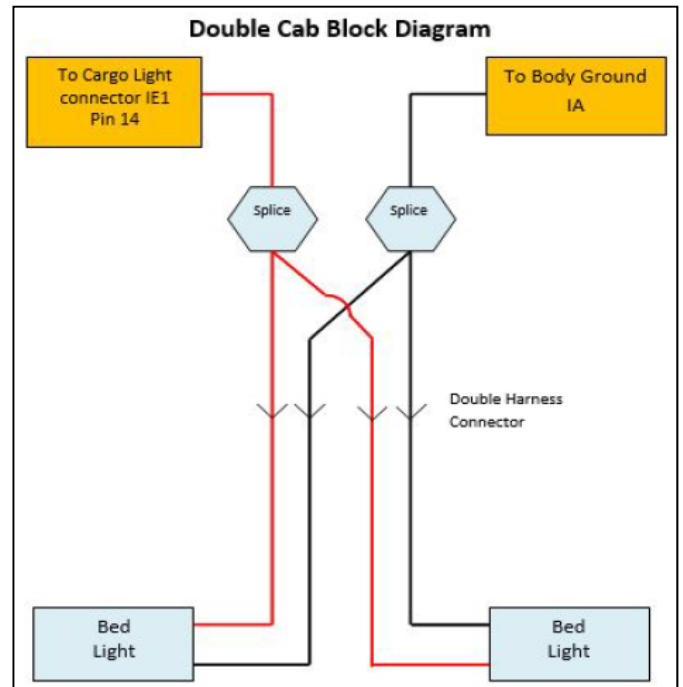

Figure 17H

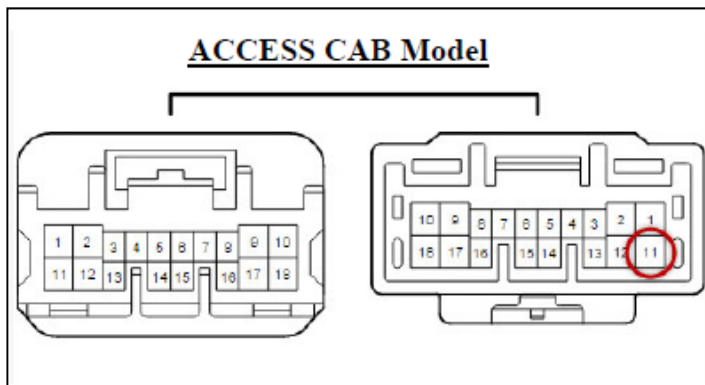

Figure 17I

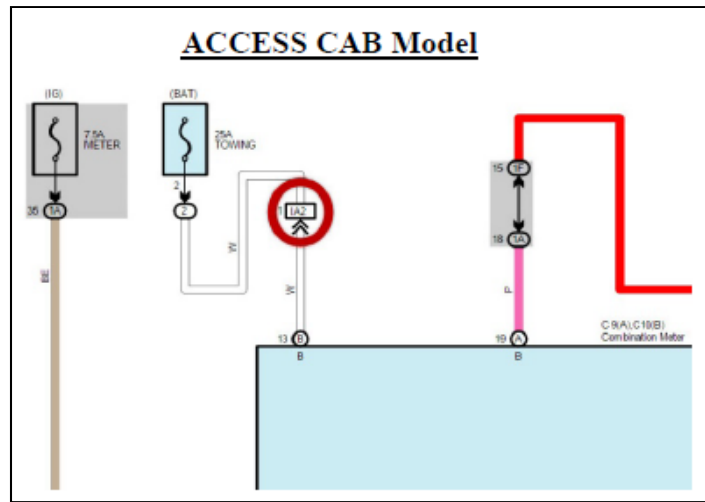

Figure 17J



Figure 17K

- c. Find IA2 BLACK connector located behind the lower driver kick panel cover. Attach a YELLOW 12 AWG T-Tap to the WHITE wire pin 11. Use pliers to ensure the T-tap is snapped in correctly. Plug the RED wire from the Bed Light LED wire harness into the T-tap. See Figures 17I, 17J, 17K & 17L.

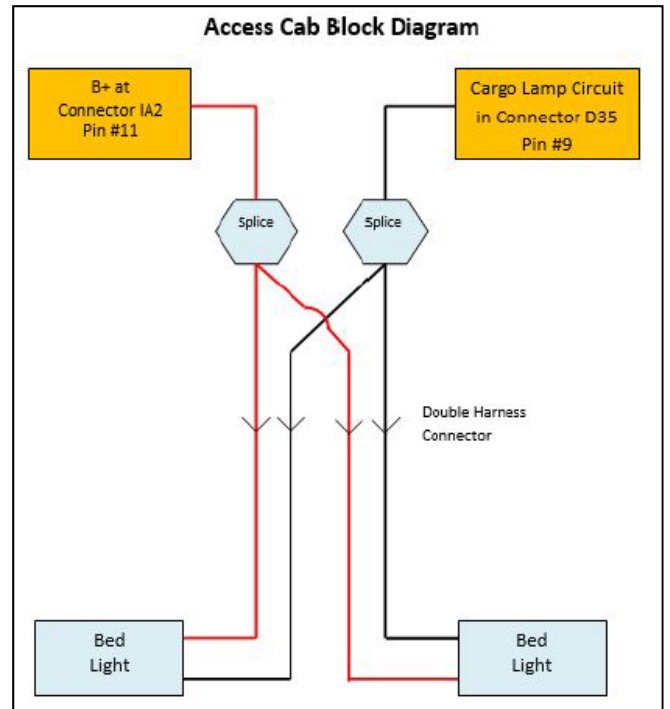

Figure 17L

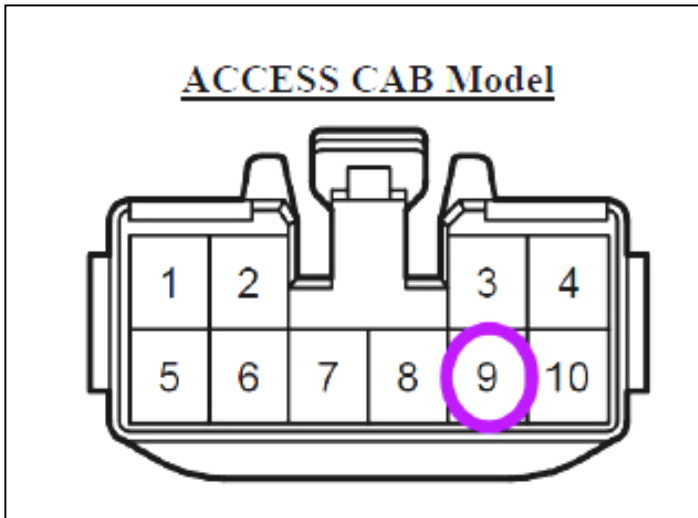

Figure 17M

- d. Find D35 BLACK connector clipped into the back of trim panel to the left of the driver’s steering wheel. Attach a RED 18-22 AWG T-Tap to the PURPLE wire Pin 9. Use pliers to ensure the T-Tap is snapped in correctly. Plug the BLACK wire from the Bed Light LED wire harness into the T-Tap. See Figures 17M, 17N & 17O.

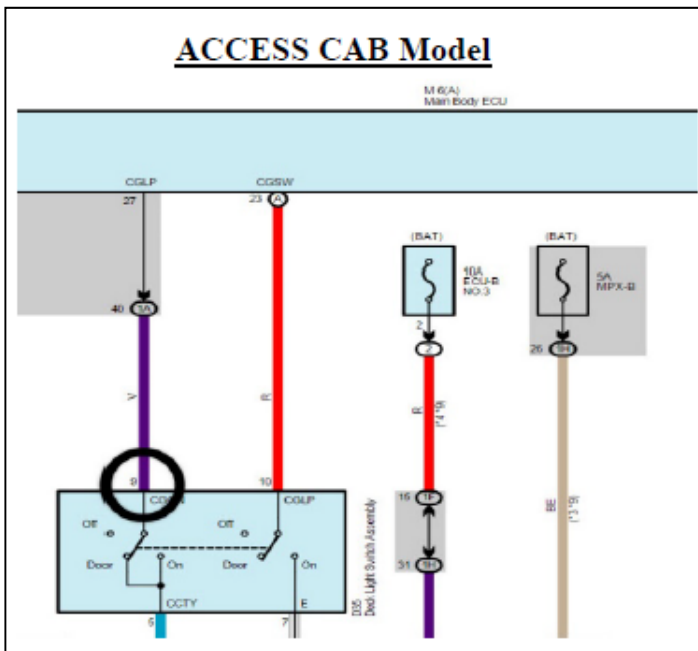

Figure 17N

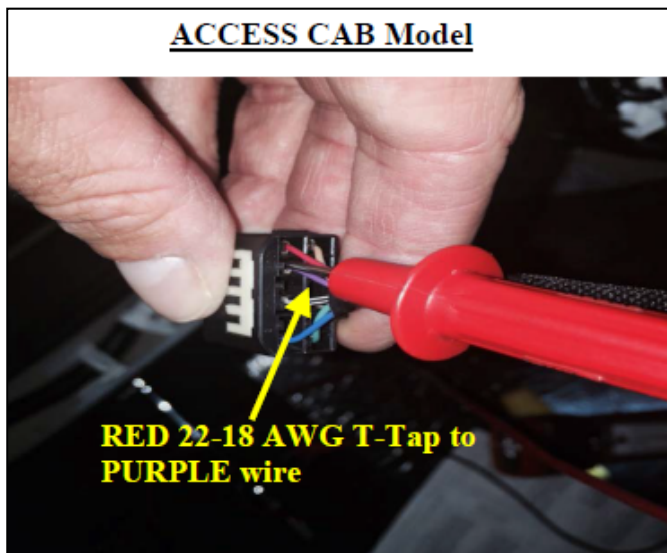

Figure 17O

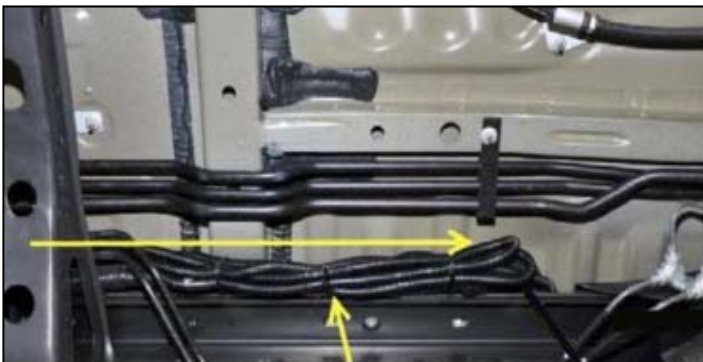

Figure 18

18. Secure wire harness along the kick panel using wire ties as needed. See Figure 18.

19. Secure excess bed light LED wire harness to OE Factory harness using wire ties in the location near the grommet. See Figure 19.

20. Trim all excess from wire ties.



Secure excess bedlight LED wire harness

21. REINSTALL ALL TRIM PANELS IN THE ORDER OF REMOVAL TAKING SPECIAL CARE TO MAKE SURE ALL HARNESS AND WIRING ARE PROPERLY SECURED. MAKE SURE HARNESSES ARE NOT PINCHED OR BOUND BY TRIM PIECES.

22. Clean up and remove trash.

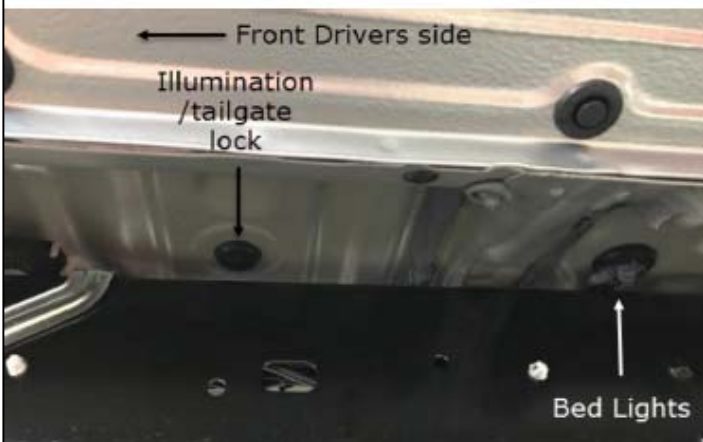

Figure 19

23. Print Warranty Statement and place in the glove box, DIO only.

24. Reconnect negative battery terminal.
Torque terminal to 48 in. lbs.



FUNCTION AND QUALITY CHECK

These points **MUST** be checked to ensure a quality installation.

ACCESSORY FUNCTION CHECK**LOOK FOR:**

- | | |
|--|--|
| ✓ LED Bed light illumination-Front Driver Door | Open the driver door. The LED Bed Light Should be on. |
| ✓ Factory Key FOB. | Close the Driver side and Passenger side door. Lock the vehicle using the key Fob. The LED Bed Lights should turn off. |
| ✓ Cargo light is illuminated (D-Cab Only) | LED Bed Light Should be on. |
| Vehicle Function Check: | |
| ✓ Check dome light. | Verify the dome light functions properly all 3 positions. |
| ✓ Cargo Light Switch | Verify exterior cargo light switch function. All 3 positions. |
| ✓ Hood Release Cable | |
| ✓ Warranty Statement | Place Warranty Statement in the glove box, DIO Only |

DIO Installation Template Passenger Side

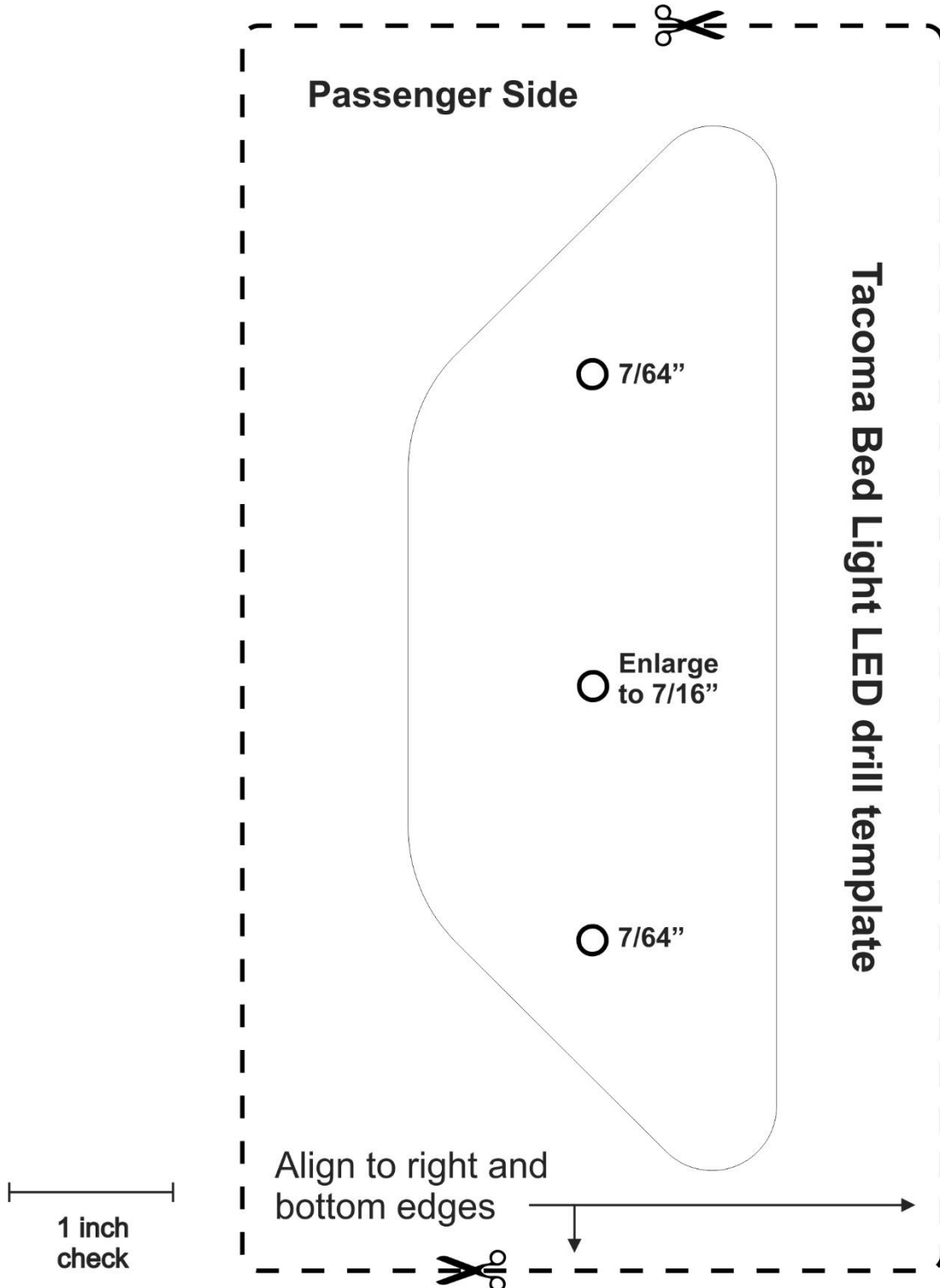

DIO Installation Template Driver Side

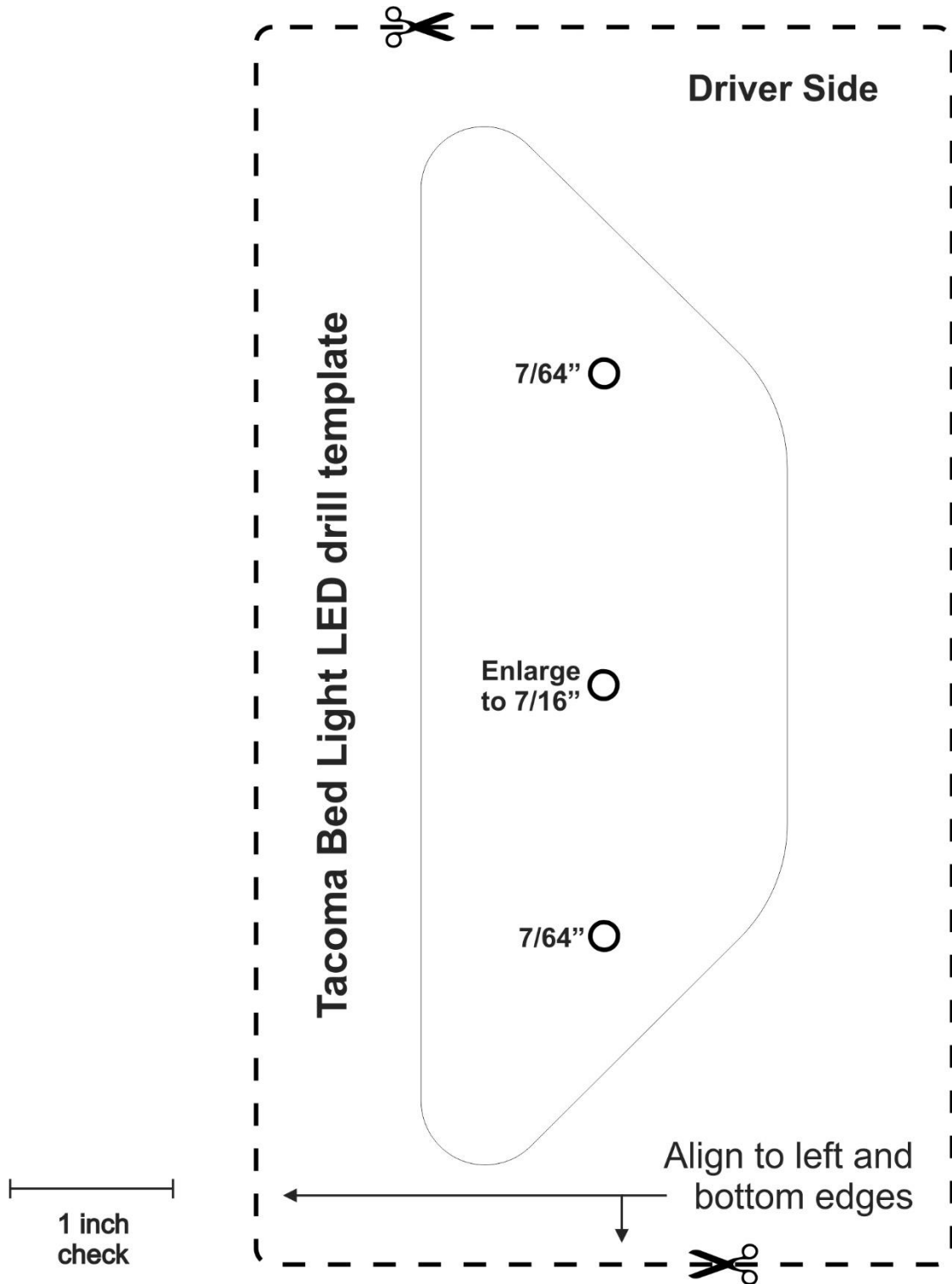

LIMITED WARRANTY – SOUTHEAST TOYOTA

SOUTHEAST TOYOTA DISTRIBUTORS, LLC (“we,” “our” and “us”) provides the following limited warranty on our accessories, excluding tires, (“Accessories” or “Accessory”) installed on a Toyota. This limited warranty is not provided by and does not bind or provide benefit to the vehicle dealer, the manufacturer, or Toyota Motor Sales, U.S.A., Inc. This limited warranty does not apply to tires; please consult the tire manufacturer and/or its materials accompanying the vehicle for any warranty terms concerning tires. This limited warranty also does not apply to ToyoGuard Exterior Paint Sealant and ToyoGuard Interior Protector; please consult the ToyoGuard Limited Warranty Certificate for the warranty terms concerning those products.

SCOPE OF LIMITED WARRANTY:

A. Protection:

- i. **Accessories Installed by Southeast Toyota Distributors, LLC on a new Toyota vehicle.** We warrant that, for a period of 36 months or 36,000 miles, whichever occurs first, we will repair or replace (includes labor), free of charge, any defect in such an Accessory due to faulty material or workmanship, or, at our option, provide a full refund of the purchase price of the Accessory. The warranty period begins on the vehicle’s In-Service Date, which is the first date the new vehicle is either delivered to an ultimate purchaser, leased, or used as a company car or demonstrator. Accessories installed by Southeast Toyota Distributors, LLC are identified on the vehicle’s window sticker (Monroney Label).
- ii. **Accessories Installed by a Toyota Dealer on a Toyota vehicle.** We warrant that, for 12 months, regardless of mileage, from the date such an Accessory was installed on the vehicle or the remainder of the Toyota new vehicle warranty, whichever is longer, we will repair or replace (includes labor), free of charge, any defect in the Accessory due to faulty material or workmanship, or, at our option, provide a full refund of the purchase price of the Accessory. For a new vehicle, the warranty period begins on the vehicle’s In-Service Date, which is the first date the new vehicle is either delivered to an ultimate purchaser, leased, or used as a company car or demonstrator.
- iii. **Accessories purchased from a Toyota Dealer but not installed by the Toyota Dealer.** We warrant that, for a period of 12 months, regardless of mileage, from the date the accessory was purchased, we will repair or replace (does not include labor), free of charge, any defect in the Accessory due to faulty material or workmanship, or, at our option, provide a full refund of the purchase price of the Accessory.

B. Limitation of Warranty. This limited warranty does not apply to, and we will not repair, replace, or reimburse you for: **(1)** wheel balancing and wheel alignments, except for one wheel balancing or alignment during the first 12 months or 12,000 miles, whichever occurs first, from the vehicle’s In-Service Date, as defined above, **(2)** abrasions or dents, whatever their cause, and any failure or damage resulting directly or indirectly from accidents, collisions, impacts from foreign objects, fire, theft, larceny, explosion, malicious mischief, vandalism, civil commotion, riots, war, or any other similar causes, **(3)** any failure or damage resulting directly or indirectly from lightning, windstorms, hail, water, floods, subfreezing temperatures, airborne chemicals, tree sap, dust, salt, and any other environmental conditions or similar causes, **(4)** any failure or damage caused by: (a) a failure of any part, other than the Accessory, (b) any misuse, abuse, improper towing, negligence or lack of maintenance of the vehicle or Accessory, (c) the alteration, modification or repair of the Accessory by anyone other than persons expressly authorized by us to perform such alteration, modification or repair, or (d) the use of the vehicle for commercial purposes, competitive driving or racing, **(5)** any failure or damage, if the Accessory has not been installed according to instructions, **(6)** any failure or damage occurring outside of Canada, the United States of America, its territories or possessions, **(7)** except to the extent required by the state whose laws govern this limited warranty, any consequential, secondary, or unreasonable costs that may be suffered as a result of the need to repair or replace the Accessory, including without limitation any loss of use of the vehicle, road service, towing, storage charges, inconvenience, loss of wages and/or income, additional expense incurred, loss of transportation, rental car expense, or any derivative damage to persons or things other than the Accessory, including other parts of the vehicle, or **(8)** liability for damage to property or for injury to or death of any person, arising out of the operation, maintenance or use of your vehicle whether or not related to the covered Accessory.

C. Exclusive Remedy. If there is a valid claim under this limited warranty for a defect due to faulty material or workmanship in the Accessory, we will, at our option, either: (i) repair, (ii) replace or (iii) provide a full refund of the purchase price of the Accessory. We have no other obligations under this limited warranty. Refunds will be made to the vehicle owner. If the vehicle is leased, the refund will be made to the leasing company.

HOW TO MAKE A CLAIM: In the event of a warranty claim, please contact the nearest Toyota dealer to arrange for repairs. The dealership must receive our prior authorization before making repairs covered by this limited warranty. The dealer will contact Southeast Toyota Distributors, LLC at 1-888-851-2722, select option #5 (Warranty Department), then option #4 (Repairs), for instructions on processing a warranty claim, if they are not already familiar with the process. If you have any questions or concerns regarding repairs covered by this limited warranty, please contact our **Customer Assistance Hotline at 1-800-301-6859**.

OUR DISPUTE RESOLUTION PROGRAM: Your satisfaction is our highest priority. In keeping with that focus, in the event that an issue arises related to this Limited Warranty, we invite you to call our Customer Assistance Hotline at 1-800-301-6859 to discuss it. In most cases, we expect that a satisfactory resolution of your issue can be reached through engagement with that Department. If our Customer Loyalty Department is unable to resolve your issue to your satisfaction, we offer a dispute resolution program administered by the National Center for Dispute Settlement (NCDS) (“the Program”). The purpose of the Program is to resolve disputes in an informal setting before an impartial arbitrator. The Program is free of charge to you (although you must bear the cost of any expert witness or attorney you elect to employ). You are required to complete the Program before exercising rights or seeking remedies under the federal Magnuson-Moss Warranty Act, 15 U.S.C. § 2301 et seq. (“the Act”). If you choose to seek remedies that are not created by the Act, you are not required to use the Program before pursuing such remedies – although the Program is still available to you to resolve the dispute. When utilizing the Program, you will need to provide (a) the vehicle identification number of your vehicle, (b) the identity of your selling and servicing dealerships, (c) the mileage on your vehicle at relevant times, (d) the date and nature of any relevant repairs, (e) legible copies of repair orders and other relevant documents, (f) a summary of the unresolved issue and the requested action, and (g) your contact information. In most cases, the dispute resolution process under the Program will be completed within forty (40) days of your submission of your request and will consist of steps such as an initial eligibility determination, an opportunity for you and us to submit information in writing relating to your claim, an oral hearing, and a decision from the arbitrator. A decision will be binding on you only if you choose to accept it. You may submit a request to NCDS by telephone at their toll free number: (877)-276-8848 or in writing at P.O. Box 463196, Mt. Clemens, MI 48046. You may obtain additional information regarding the Program at www.ncdsusa.org. In the event that the NCDS does not exist or no longer handles disputes for us at the time that you seek to submit a request, you may contact our **Customer Assistance Hotline at 1-800-301-6859** to obtain current information about our dispute resolution programs.

GENERAL LIMITATION OF WARRANTY: THIS LIMITED WARRANTY IS IN LIEU OF ALL OTHER EXPRESS WARRANTIES OR LIABILITIES. IN NO EVENT SHALL WE BE LIABLE FOR ANY CONSEQUENTIAL OR INCIDENTAL DAMAGES FOR BREACH OF THIS OR ANY OTHER WARRANTY. SOME STATES DO NOT ALLOW THE EXCLUSIONS OR LIMITATIONS OF INCIDENTAL OR CONSEQUENTIAL DAMAGES, SO THE ABOVE INFORMATION OR EXCLUSION MAY NOT APPLY. NO EXPRESS WARRANTY OF FITNESS OR MERCHANTABILITY IS GRANTED BY THIS LIMITED WARRANTY. THERE ARE NO WARRANTIES WHICH EXTEND BEYOND THOSE DESCRIBED IN THIS DOCUMENT. ANY IMPLIED WARRANTIES, INCLUDING THE IMPLIED WARRANTY OF MERCHANTABILITY OR FITNESS FOR A PARTICULAR PURPOSE, WHICH MAY BE APPLICABLE BY OPERATION OF LAW SHALL BE LIMITED TO THE PERIOD OF THIS WRITTEN LIMITED WARRANTY. SOME STATES DO NOT ALLOW LIMITATIONS ON HOW LONG AN IMPLIED WARRANTY LASTS, SO THE ABOVE LIMITATIONS MAY NOT APPLY. THIS LIMITED WARRANTY PROVIDES SPECIFIC LEGAL RIGHTS, AND THERE MAY BE OTHER RIGHTS WHICH VARY FROM STATE TO STATE. ANY ACTION FOR BREACH OF ANY WARRANTY HEREUNDER, INCLUDING ANY IMPLIED WARRANTY OF MERCHANTABILITY, MUST BE BROUGHT WITHIN A PERIOD NOT EXCEEDING 12 MONTHS AFTER EXPIRATION OF THIS LIMITED WARRANTY. THE REMEDIES SPECIFIED HEREIN AND THOSE SPECIFIED BY APPLICABLE LAW ARE THE ONLY REMEDIES AVAILABLE. WE ASSUME NO OTHER OBLIGATION OR RESPONSIBILITY WITH REGARD TO THE ACCESSORY. WE NEITHER ASSUME, NOR AUTHORIZE ANYONE TO ASSUME FOR US, ANY ADDITIONAL LIABILITY IN CONNECTION HEREWITH.

GENERAL: This limited warranty describes the complete and exclusive rights that result from the purchase of Accessories. No oral representations or statements may be relied upon. This limited warranty may not be amended or modified, and additional rights may not be granted, unless in a written statement signed by one of our officers. This limited warranty shall be governed by the laws of the state where the vehicle is purchased, excluding laws concerning conflicts of law. We may delegate the performance of our duties and obligations and assign our rights and benefits hereunder. For inquiries regarding this limited warranty, we can be contacted directly at **Customer Assistance Hotline at 1-800-301-6859**, or by mail to: **Southeast Toyota Distributors, LLC, Attention: Customer Loyalty Department, 100 Jim Moran Boulevard, Deerfield Beach, Florida 33442.**