



**Southeast Toyota Distributors, LLC
Accessory Installation Instructions**

**2018 Highlander
Frameless EC Mirror
w/Compass & Homelink**

Year & Model:	2018 Highlander
Part Number:	00016-05464
Accessory Code:	ME4000
PIO / DIO:	PIO / DIO
Business Partner:	L42

Conflicts

Note: Factory Homelink

General Applicability

Fits Models	
1	All Models, except factory installed Homelink

Additional Items Required For Installation

Item#	Description:
1	(1) Lower A-Pillar Clip (62217-52120)
2	(1) Upper A-Pillar Clip (62217-0E040)

Sequence of Application

Item#	Accessory:
1.	N/A

SPECIAL NOTE: Installation Sequences

After TMS & Safety mandated preparatory steps have been taken, the installation sequence is the suggested method for completing the accessory installation. In some instances the suggested sequence is written for one associate to install & in others the sequence is given as part of a team accessory installation. Unless otherwise stated in the document, the associates may perform the installation steps in any order to make the installation as efficient as possible while maintaining consistent quality.

Recommended Tools

Safety Tools	
Safety Glasses	
Installation Tools	Notes
Needle Nose Pliers	
Screw Gun	
10mm Socket	
T20 Torx Bit/Driver	
#2 Phillip Bit	
Nylon Tool	
Ratchet Driver	
Dark Towel/Cloth	
Torque Wrench 15.5 inch lbs.	
Torque Wrench 48inch lbs.	

Legend

STOP: Damage to the vehicle may occur. Do not proceed until process has been complied with.

OPERATOR SAFETY: Use caution to avoid risk of injury.

CAUTION: A process that must be carefully observed in order to reduce the risk of damage to the accessory/vehicle and to ensure a quality installation.

TOOLS & EQUIPMENT: Used in Figures calls out the specific tools and equipment recommended for this process.

REVISION MARK: This mark highlights a change in installation with respect to previous issue.

SAFETY TORQUE: This mark indicates that torque is related to safety.

Table of Contents

- I. Preparation.....1-6
 - a.) Table of Contents.....2
 - b.) Kit/Hardware & Wire Harness Bag Contents.....3
 - c.) Parts for Installation.....4
 - d.) Service & Warranty Information.....5
 - e.) Battery Preparation.....6-7

- II. Procedures
 - a.) Vehicle Disassembly.....8-11
 - b.) Vehicle Installation.....12-21
 - c.) Battery Installation.....21

- III. Compass & Calibration Setting.....22
- IV. Functions & Quality Check.....23
- V. Block Diagrams & Connectors.....24-27
- VI. Blank Page.....28
- VII. Warranty Statement.....29-30

Kit/Hardware Bag Contents:

Item #	Quantity	Description
1.	1	Red T-Taps
2.	1	Wire Ties
3.	1	Foam Tape
4.	3	Quick Reference Guide

Parts for Installation:

Care must be taken when installing this accessory to ensure damage does not occur to the vehicle. The installation of this accessory should follow approved guidelines to ensure a quality installation. These guidelines can be found in the “Accessory Installation Practices” document.

This document covers such items as:

- Vehicle Protection (use of covers and blankets, cleaning chemicals, etc.).
- Safety (eye protection, re-checking torque procedure, etc.).
- Vehicle Disassembly/ Reassembly (panel removal, part storage, etc.).
- Electrical Component Disassembly/Reassembly (battery disconnection, connector removal, etc.).

Item #	Quantity	Description
1.	1	Frameless® Mirror w/Compass & HomeLink®
2.	1	Wire Harness Cover
3.	1	Main Power Wire Harness

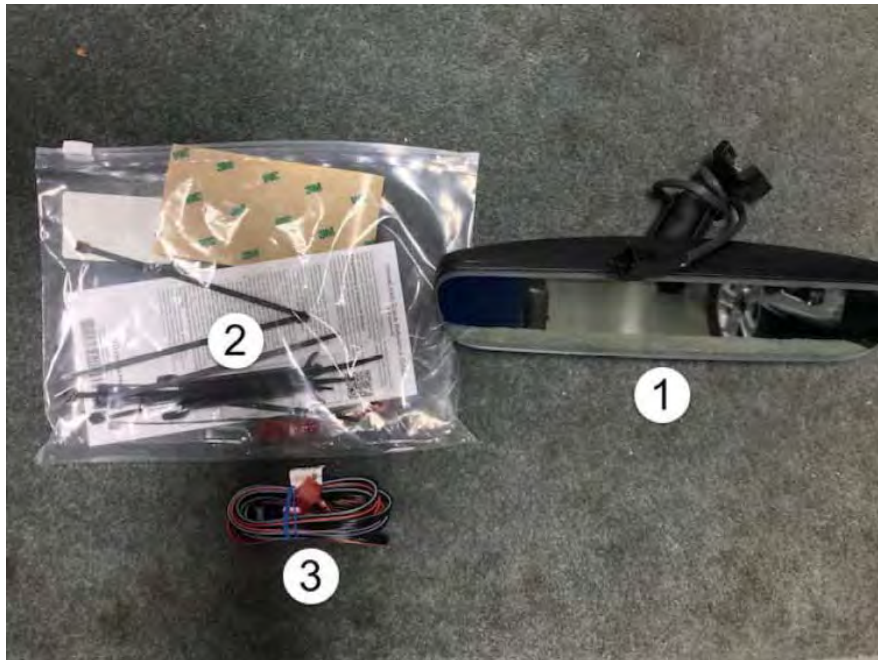

Service & Warranty Information:

Image Key	Parts information		Warranty Information	
	Part Number	Description	Warranty Time	Labor Op. Code
AA	00016-05464	EC Mirror w/Comp. and HL	00.55	AHM001
BB	00016-35463-04	Mirror Wire Cover Cover	00.11	AHM002

If you are a dealer located outside of the Southeast Region, please contact the SET Accessory Warranty Department at (888) 851-2722 or email Accessory.Warranty@SEToyota.com for claim payment instructions.

Image:



Battery Preparation

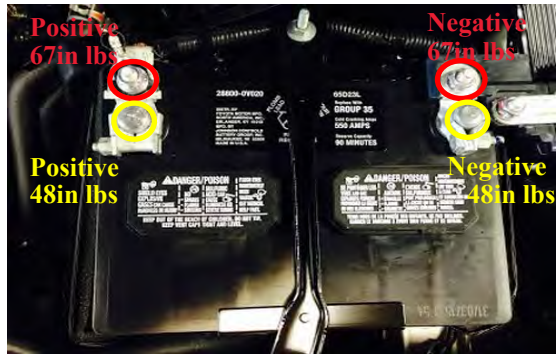

Option 1: If the battery clamp nut cannot be accessed to set torque to the recommended specification without removing additional panels & /or other components. You may change (reverse the direction) the negative battery clamp bolt & nut. Battery terminal must have torque set to factory specification . **CAUTION:** Do not touch the positive terminal. Re-torque to 48in lbs.

Option 2: Removing the 12mm nut from the positive or negative terminal junction. When re-tightening the torque specification is 67in lbs.

NOTE: It is recommended to use Option 1 when a lead wire is not being installed. However Option 2 is to be used when a lead wire is being added to the positive side, or anytime the negative side 12mm nut is being removed, re-torque both to 67in lbs.

NOTE: If removal of the positive battery terminal 12mm nut is required to install a lead wire, the negative battery terminal must be disconnected first to disable the electrical system. The positive battery or terminal should never be disconnected unless the negative battery terminal is first removed & waiting 90 seconds for the SRS system to power down.

Battery Preparation

Negative (-)
Terminal

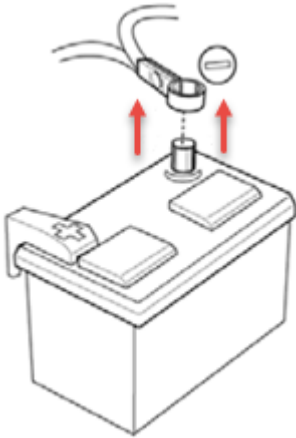

Figure 1

1. Disconnect the negative battery cable. Isolate the cable with protection in place. Figure 1.



Wait at least 90 seconds after disconnecting the cable from the negative (-) battery terminal to disable the SRS system.

Vehicle Preparation

2. Remove the driver side visor holders. Turn the holder clockwise approximately 45° and pull it as shown in the illustration. Detach the 2 claws and remove the visor holder. Figure 2.

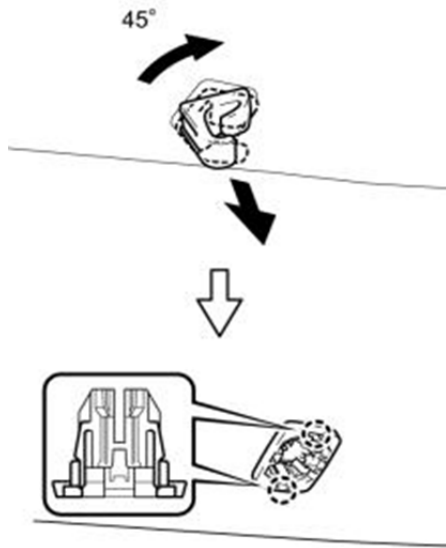

Figure 2

3. Detach the 4 clips. Disconnect the connector to remove the roof console box. Figure 3.

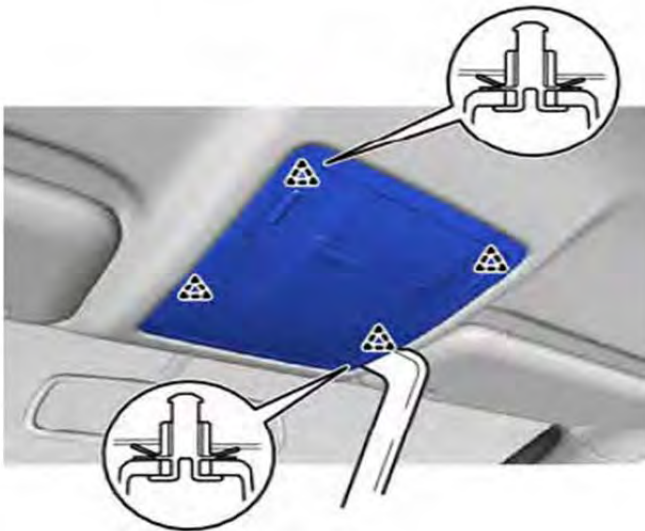

Figure 3



4. Pull the upper part of the front LH pillar garnish toward the inside of the cabin and disengage from the base of the 2 front pillar garnish clips. Figure 4.

HINT: Let the front LH pillar garnish hang from the 2 front pillar garnish clips.

Figure 4

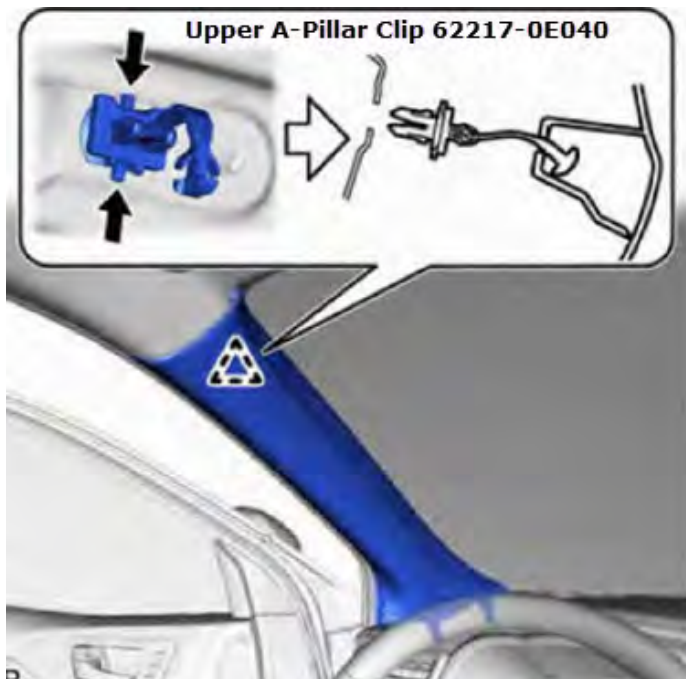

Figure 5

5. While pushing the tabs on the LH front A-Pillar garnish clip (A) in the direction indicated by the arrow shown in the illustration, disengage the LH front A-Pillar garnish clip (A). Remove the LH front A-Pillar clip from the A-Pillar. The clip CAN NOT be reused. DESTROY and DISPOSE of clip. Figure 5.



NOTE: Install a new A-Pillar garnish upper clip when replacing A-Pillar garnish at the end of installation. Upper A-Pillar clip 62217-0E040 is not provided in the mirror kit. This item must be ordered separately.

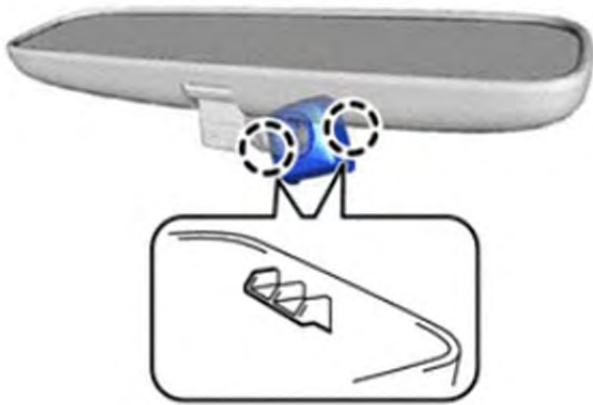

Figure 6

6. Using needle-nose pliers with the tips wrapped with protective tape, rotate the front pillar garnish clip (B) 90° in the direction indicated by the arrow (1) shown in the illustration. Pull the LH front pillar garnish in the direction indicated by the arrow (2) shown in the illustration to disengage it from the front pillar garnish clip (B). Pull the LH front pillar garnish in the direction indicated by the arrow (3) shown in the illustration to disengage the 2 guides to remove the LH front pillar garnish. Remove the LH front A-Pillar clip from the A-Pillar. The clip CAN NOT be reused. DESTROY and DISPOSE of clip. Figure 5 & 6.



NOTE: Install a new A-Pillar garnish lower clip when replacing A-Pillar garnish at the end of installation. Lower A-Pillar clip 62217-52120 is not provided in the mirror kit. This item must be order separately.



- 7. Disengage the 2 claws and disconnect the inner mirror base cover. Figure 7.

Figure 7

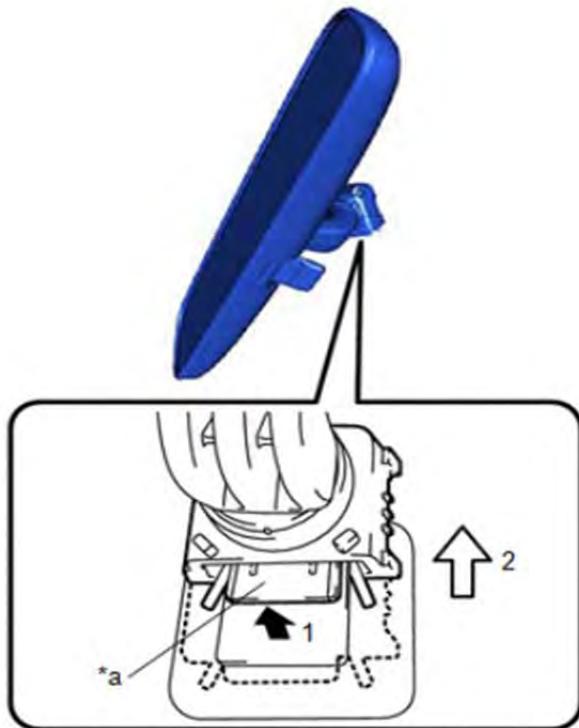

- 8. Pull the lock lever in the direction indicated by the arrow (1) in the illustration, and slide the inner rear view mirror assembly in the direction indicated by the arrow (2) to remove it. Figure 8.

*a	Lock Lever
----	------------

Figure 8

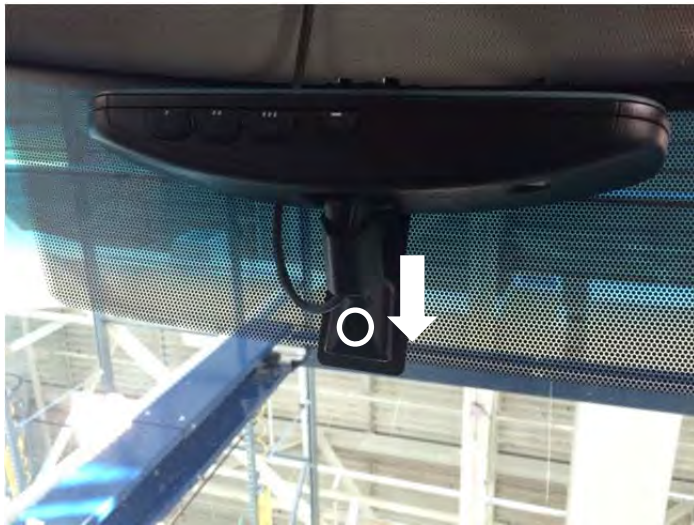

Note: Remove fingerprints, smudges, dirt, etc. from mirror and windshield with glass cleaner.

Figure 9a

Vehicle Installation

- 9. Mount the Frameless® EC Mirror w/Compass in reverse of original factory mirror removal. Slide and attach the rearview mirror assembly and tighten mirror set screw with a T20 torx bit or driver. DO NOT over tighten screw. Figure 9a & 9b.

S Torque: 15.5 in.*lbf

STOP Do not use power tools to tighten screw. Hands tighten only.

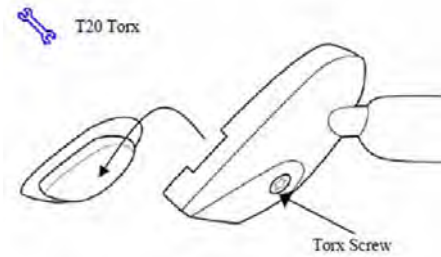

Figure 9b



Figure 10

10. Route the mirror harness to overhead console opening using the precut notches on the front of the headliner. Figure 10.

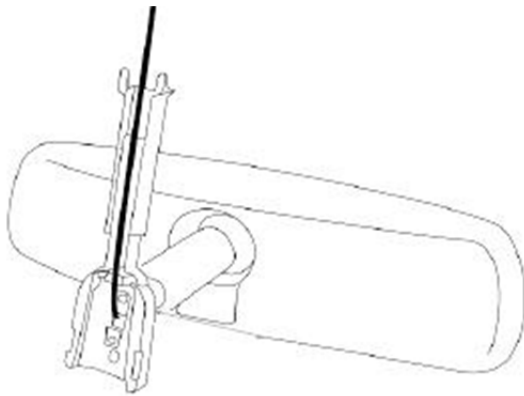
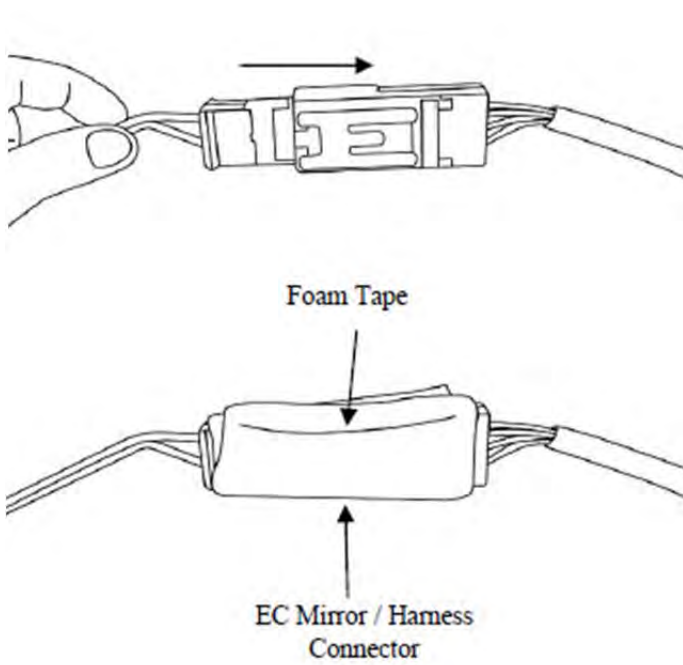

Figure 11a

11. Install the wire harness cover over the wire harness. Seat the bottom of the cover securely to base of the mirror. Extend the top of the cover fully into headliner. Figure 11a and 11b.

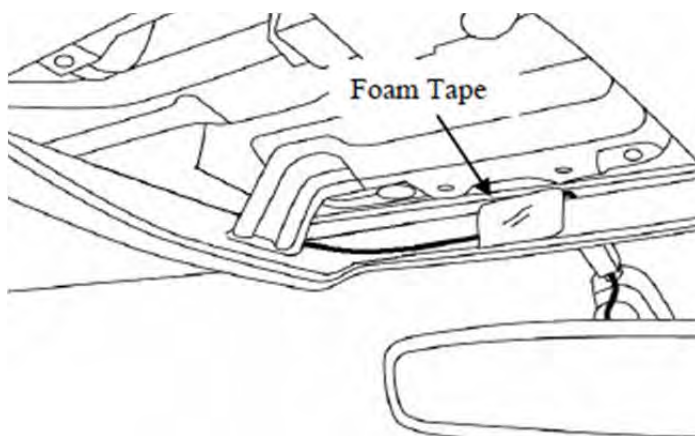

Figure 11b



12. Connect the mirror harness to the mirror main power harness. Make sure both connectors are fully engaged. Wrap foam tape around connectors. Figure 12.

Figure 12



13. Secure the harness to the front center of the headliner with one (1) piece of foam tape. Figure 13.

Figure 13

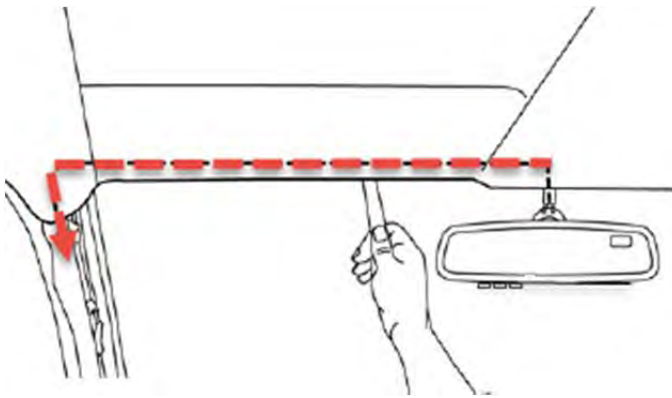

- 14. Route mirror main power harness along front edge of headliner towards the LH vehicle A-Pillar. Figure 14.

Figure 14



- 15. Route the mirror harness down to the bottom of the Front LH pillar. Route the harness through the factory harness clips attached to the vehicle. Wire tie the harness to the vehicle harness as shown. Figure 15.

Figure 15

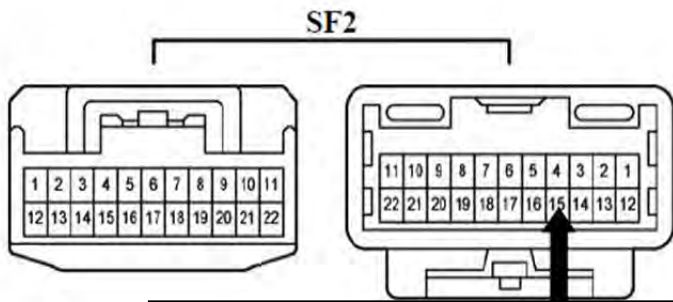

T-Tap the mirror main power harness ignition power wire (black/white) to Pin 15 violet wire in grey connector SF2.

16. Locate vehicle connector SF2 in the front LH pillar. Disconnect connector and pull the factory tape back. T-Tap the mirror main power harness ignition power wire (black/white) to Pin 15 violet wire in grey connector SF2. Figure 16a & 16b.

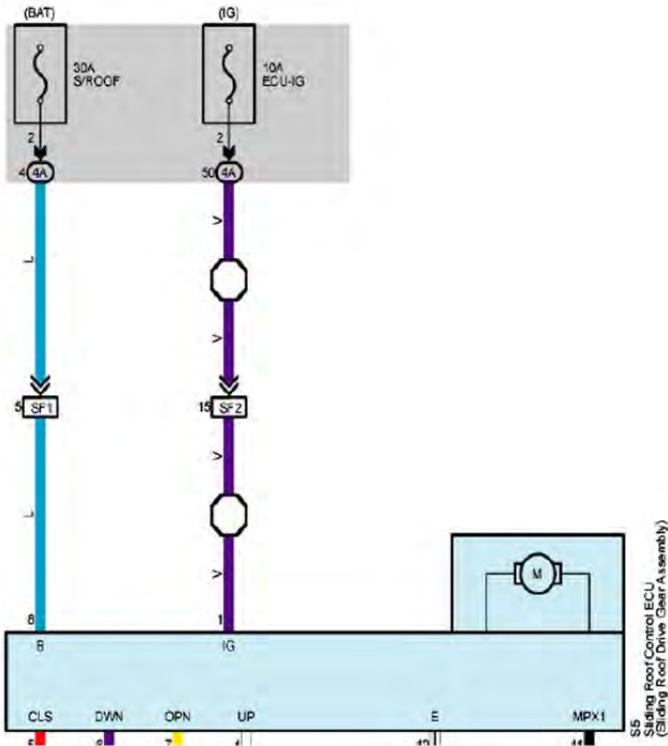

Figure 16a

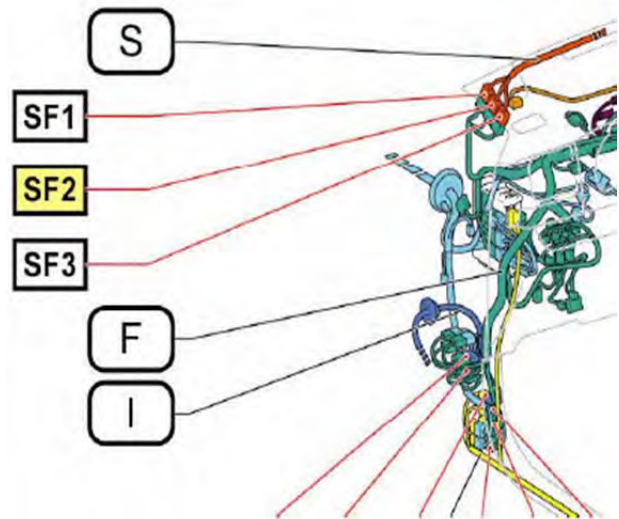
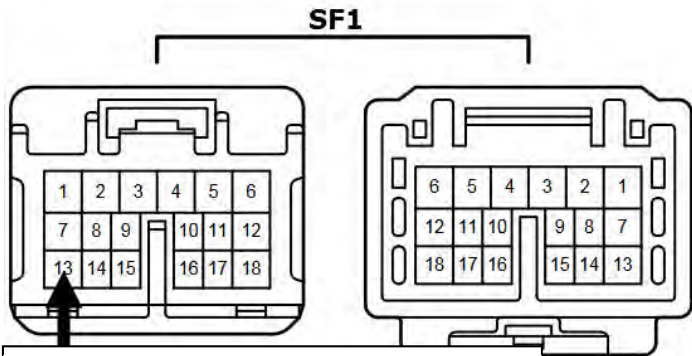

Figure 16b



T-Tap the mirror main power harness ground wire (black/orange) to Pin 13 white/black wire in white connector SF1.

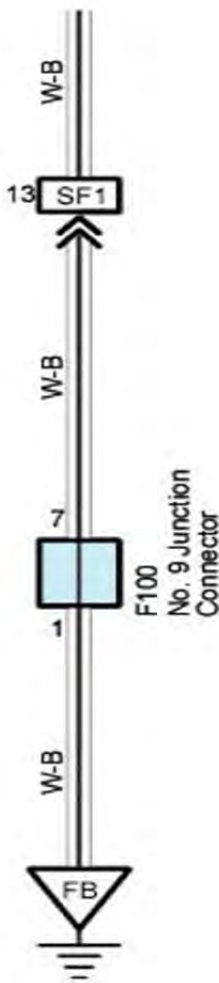

Figure 17a

17. Locate vehicle connector SF1 in the Front LH pillar. Disconnect connector and pull the factory tape back. T-Tap the mirror main power harness ground wire (black/orange) to Pin 13 white/black wire in white connector SF1. Figure 17a & 17b.

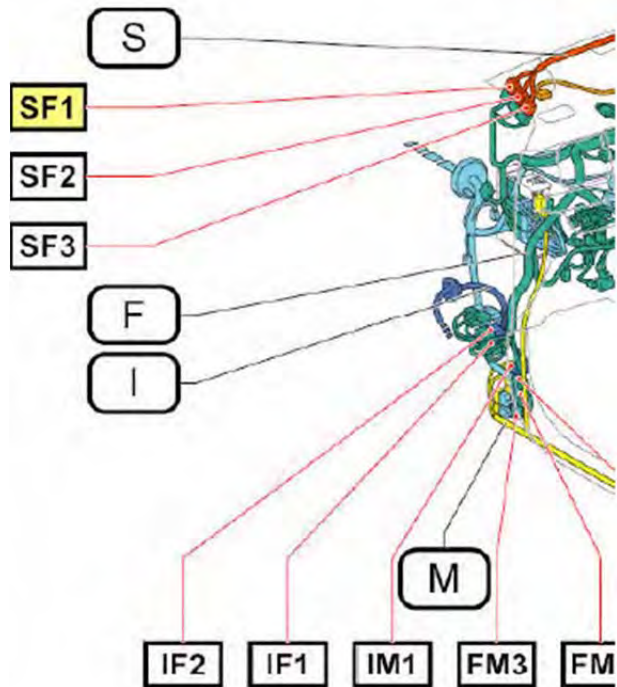
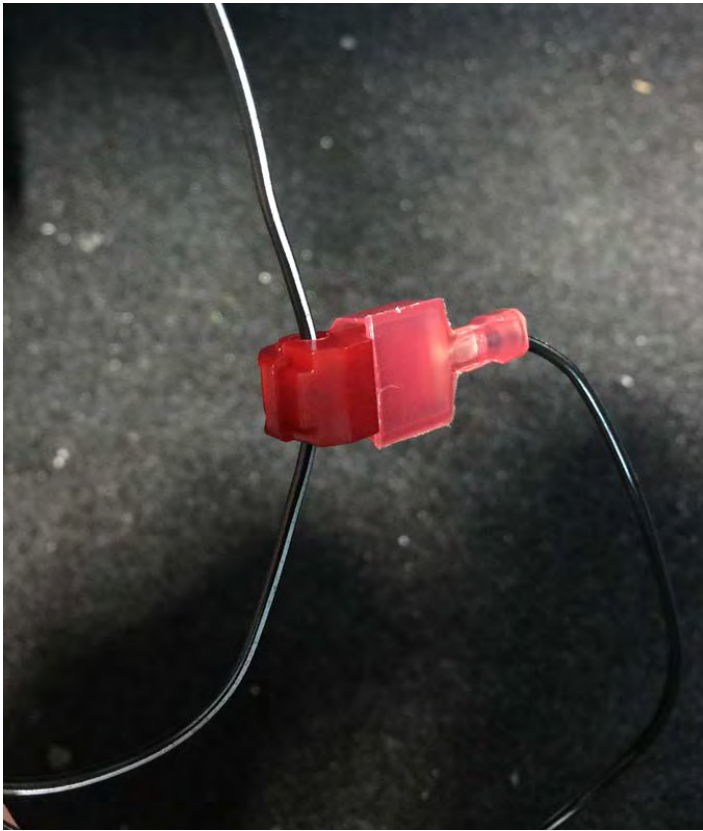

Figure 17b



18. T-Tap the mirror main power harness power wire (black) to the mirror main power harness ignition wire (black/white). Figure 18.

Figure 18

19. Bundle up any excess wire above the headliner and secure it to the vehicle harness near the overhead console.



Figure 19

20. Engage the 4 clips to install the map light assembly. Figure 19.

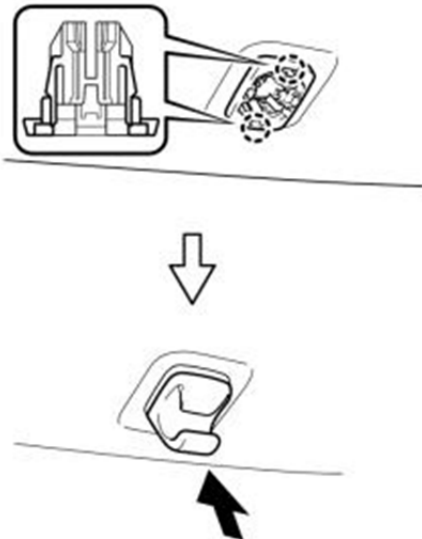
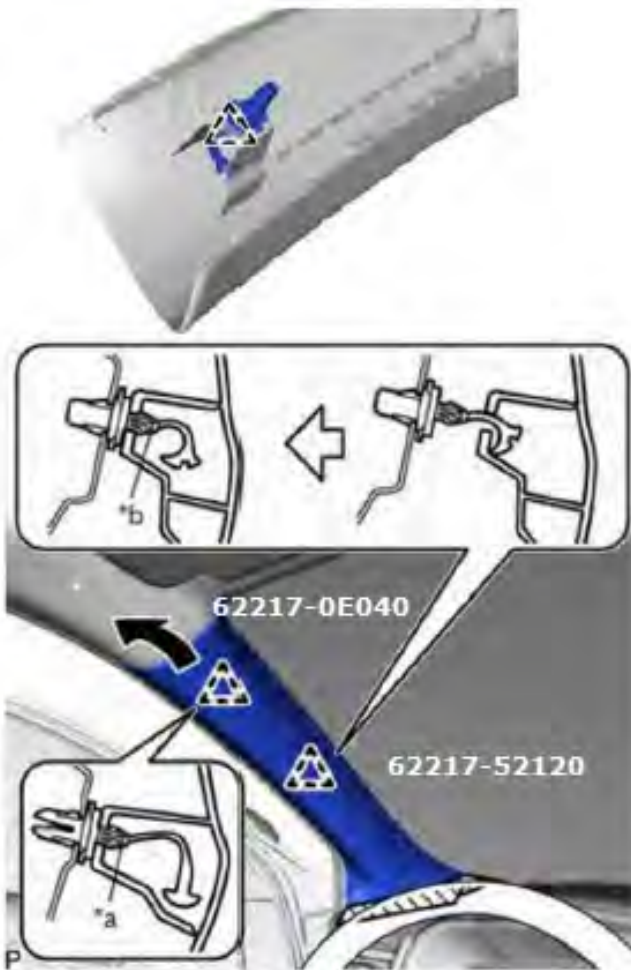

Figure 20

21. Engage the two claws. Push in the visor holder to install. Figure 20.

22. Install the New A-Pillar garnish upper clip 62217-0E040 to vehicle A-Pillar garnish. Install the New A-Pillar garnish lower clip 62217-52120 to vehicle A-Pillar garnish.



NOTE: Install a new A-Pillar garnish upper clip and lower clip when installing garnish. DO NOT reuse the old clips. THE CLIPS MUST BE REPLACED.

Lower A-Pillar clip 62217-52120 and upper A-Pillar clip 62217-0E040 is not provided in the mirror kit. This item must be ordered separately.

Engage the front pillar garnish clips to the front LH pillar garnish. Install the LH front pillar garnish back onto vehicle. Figure 21.

Figure 21

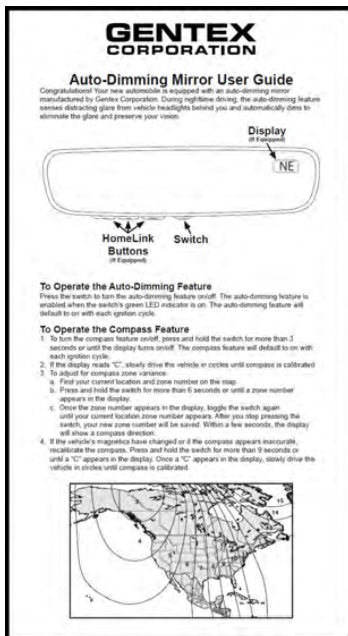

Figure 22

23. Place owner's card in the glove box.
Figure 22.

Battery Installation

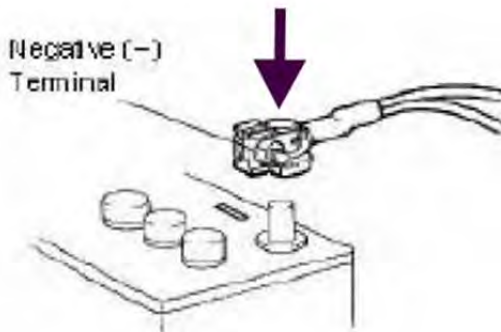



Figure 23

24. Connect the negative battery cable. Figure 23.

 Torque: 48in.*lbf

25. Print Warranty Statement and place in glove box,
DIO Only.

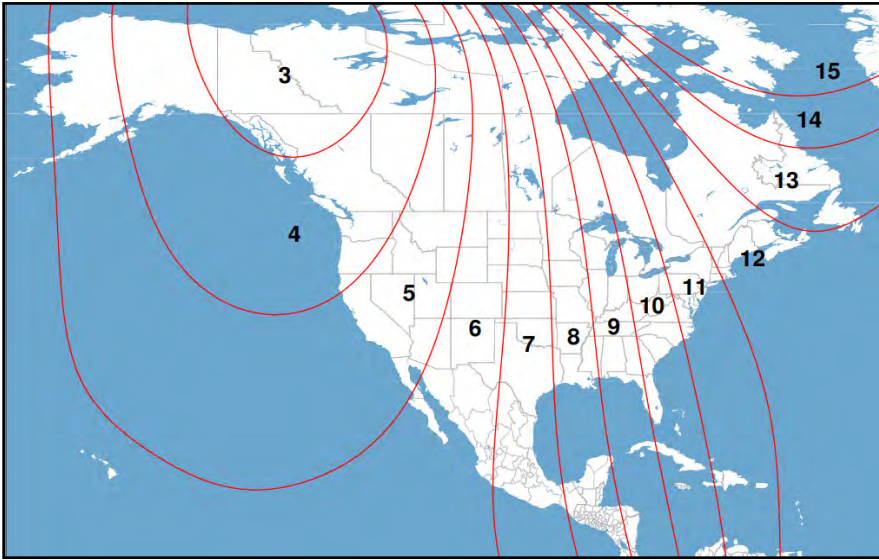

Figure 24

1. Compass Zone Setting.

- a. With display turned ON, push the mirror power button for 3 seconds or until a number is displayed in the display window.

- b. **PIO: Set to Zone 10.**
DIO: Refer to the Zone Map and toggle button until correct zone is displayed. See Figure 24.

- c. Release button.

- d. The display will return to normal compass mode (showing either a "C" or a directional heading) within 10 seconds of no switch activity.

2. Calibrate Compass.

- a. If a "C" is displayed in window, drive the vehicle in one circle at less than 5 mph.
- b. Correct compass heading should now be displayed.

NOTE: Correct compass zone must be selected prior to compass calibration to ensure accurate calibration. If the vehicle is driven in a new zone, repeat zone selection procedure.

Checklist - these points **MUST** be checked to ensure a quality installation.

Functions & Quality Check

Look For:

- ✓ Vehicle should be in a fairly well lit area. Turn ignition (ACC power) to ON.

Auto-dimming feature:

✓ Cover the forward-looking light sensor (located on the back of the mirror).

Mirror clears:

✓ Remove cover from photocell.

Compass Feature:

✓ Look at the mirror compass display.

✓ Operation Instruction Cards

HomeLink Feature:

✓ Look at the mirror's (3) HomeLink buttons.

✓ Press the mirror's (3) HomeLink buttons.

Overhead Console:

✓ Check dome light.

✓ Check the Sunroof if applicable.

✓ Warranty Statement

Verify green LED is on. If it is not ON press ON / OFF button - confirm LED is ON.

Verify mirror darkens.

Mirror returns to clear state.

Correct compass heading should now be displayed. If a "C" is displayed in window, calibrate the compass.

Place in the vehicle glove box.

Verify all (3) buttons are illuminated when the vehicle ignition is ON.

HomeLink icon will appear in mirror. Press button again to stop the icon from flashing.

Verify the dome light functions properly.

Verify the sunroof functions properly.

Place Warranty Statement in glove box, DIO Only.

Block Diagram
Frameless® EC Mirror w/Compass & HomeLink®

Applies to SET P/N 00016-05464 **Highlander**

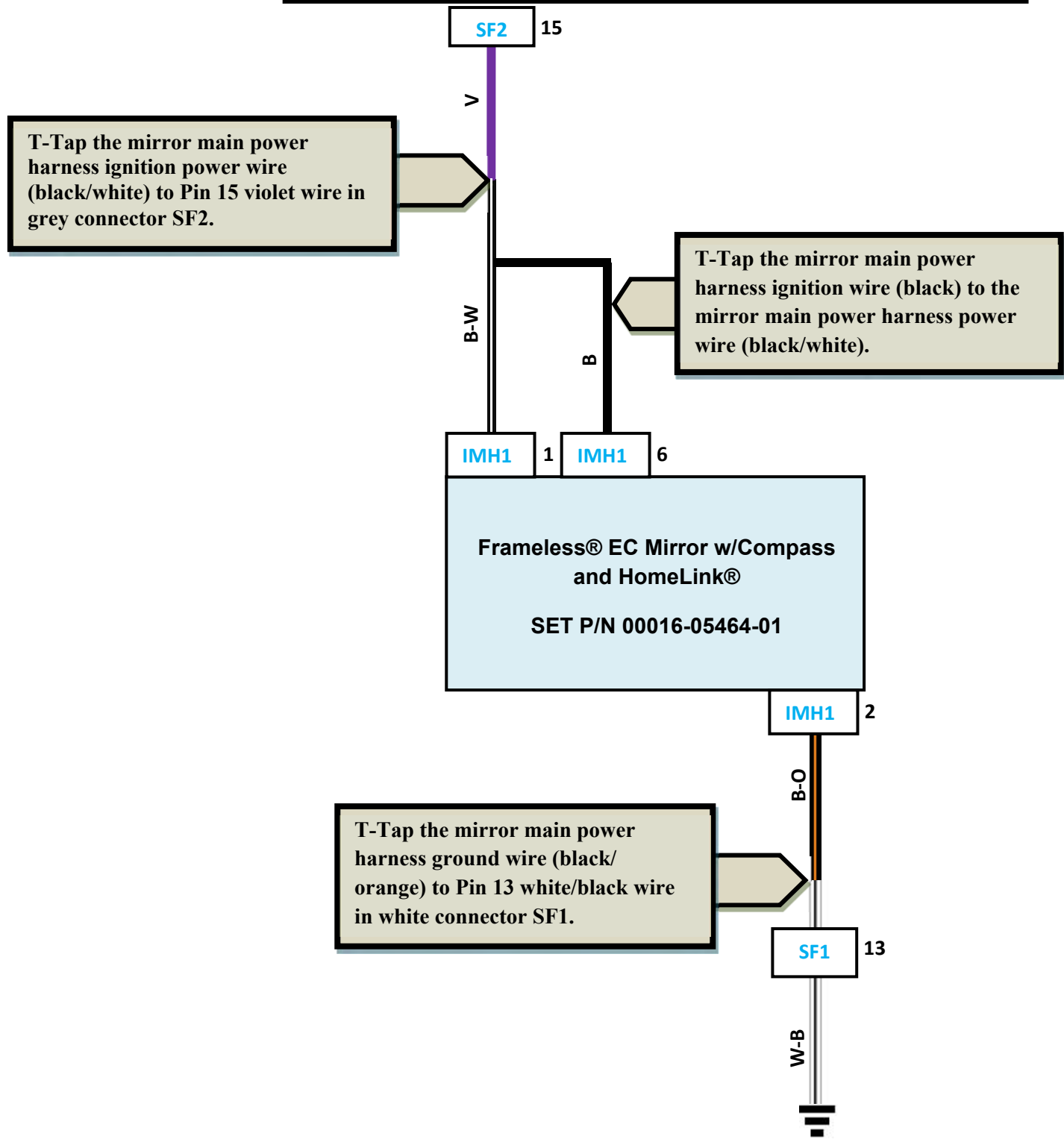

Checking the Harness Pin outs:

Connector IMH1: Frameless® EC Mirror w/Compass Power Harness Connector

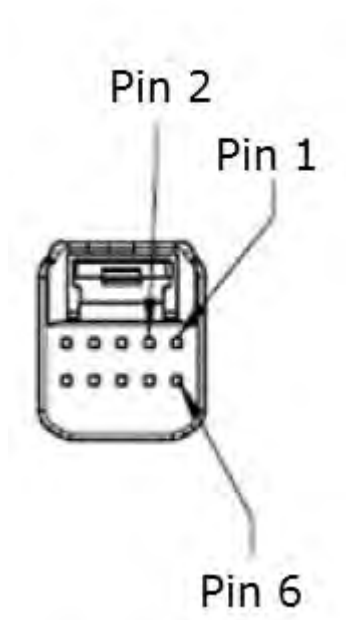

Connector view is from the front (pin side)

If feedback from the harness on any of the pins does not match the results shown in the Proper Operation field below, check the connection to the vehicle wiring and re-test.

Pin	Wire Color	Test Reference	Proper Operation
1	Black w/White Trace	Pin 1 to ground	Approx. 12 VDC with switch in ON position Approx. 0 VDC with switch in OFF position
2	Black w/Orange Trace	Pin 2 to ground	Always Continuity
6	Black	Pin 3 to ground	Approx. 12 VDC with switch in ON position Approx. 0 VDC with switch in OFF position

Pin	Wire Color	Circuit
1	Black w/White Trace	Ignition
2	Black w/Orange Trace	Ground
6	Black	Battery

Vehicle Connector SF2-Power Circuit

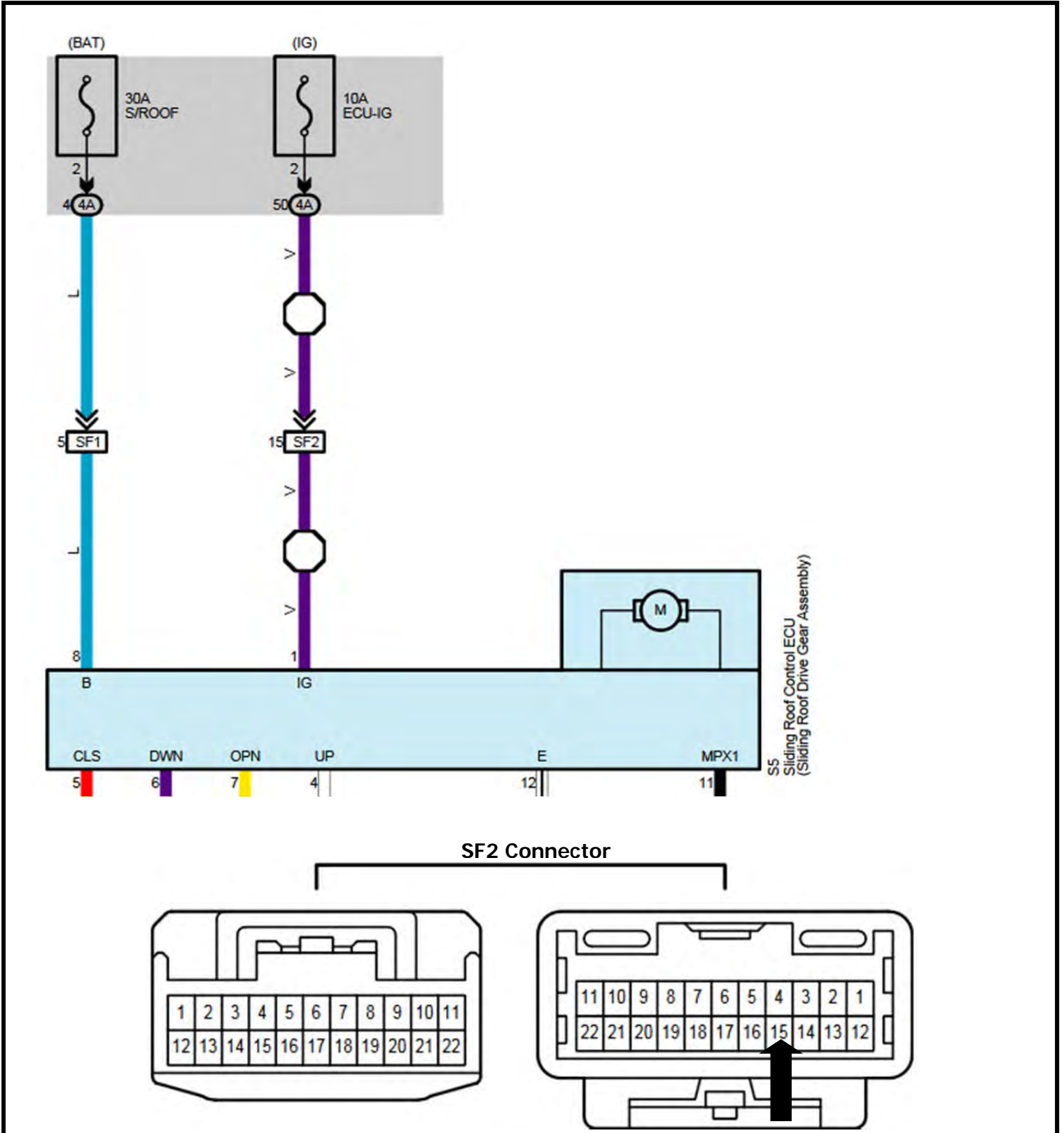

Vehicle Connector SF1-Ground Circuit

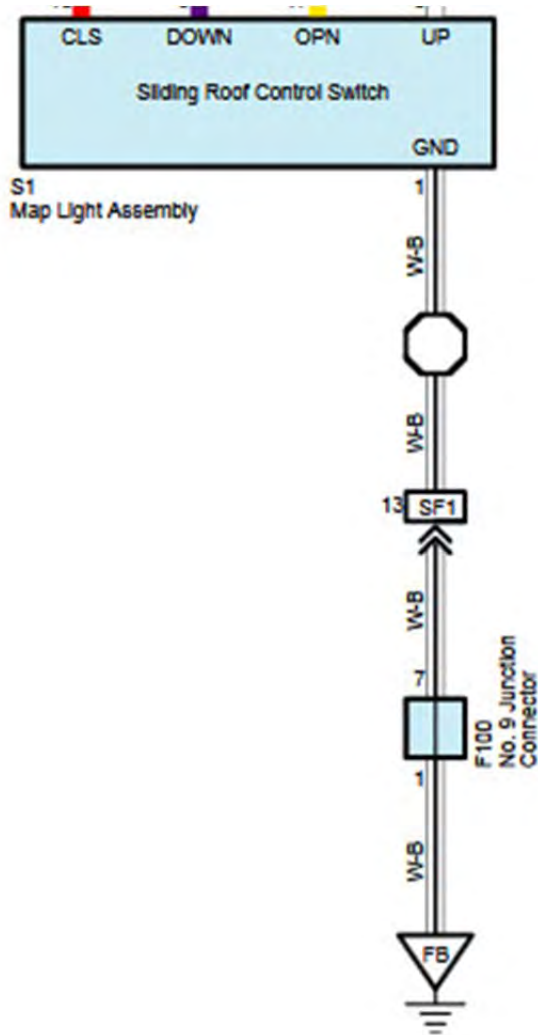

SF1 Connector

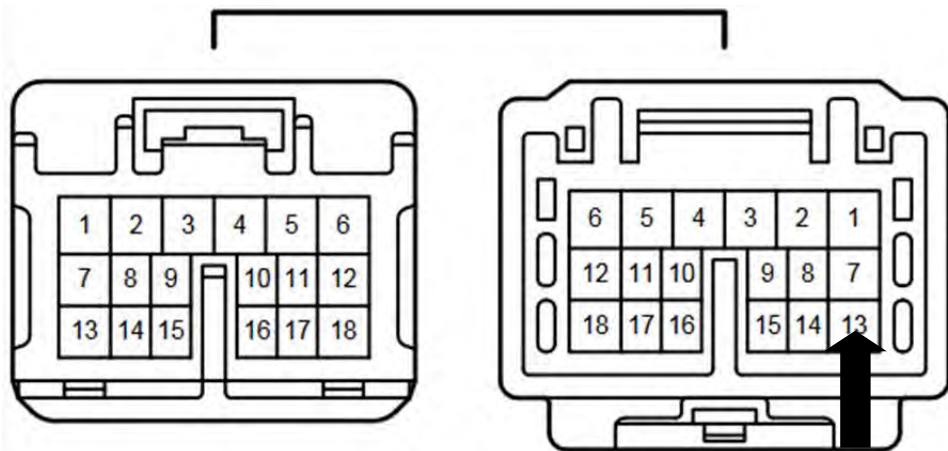



LIMITED WARRANTY – SOUTHEAST TOYOTA

SOUTHEAST TOYOTA DISTRIBUTORS, LLC ("we," "our" and "us") provides the following limited warranty on our accessories, excluding tires, ("Accessories" or "Accessory") installed on a Toyota. This limited warranty is not provided by and does not bind or provide benefit to the vehicle dealer, the manufacturer, or Toyota Motor Sales, U.S.A., Inc. This limited warranty does not apply to tires; please consult the tire manufacturer and/or its materials accompanying the vehicle for any warranty terms concerning tires. This limited warranty also does not apply to ToyoGuard Exterior Paint Sealant and ToyoGuard Interior Protector; please consult the ToyoGuard Limited Warranty Certificate for the warranty terms concerning those products.

SCOPE OF LIMITED WARRANTY:

A. Protection:

- i. **Accessories Installed by Southeast Toyota Distributors, LLC on a new Toyota vehicle.** We warrant that, for a period of 36 months or 36,000 miles, whichever occurs first, we will repair or replace (includes labor), free of charge, any defect in such an Accessory due to faulty material or workmanship, or, at our option, provide a full refund of the purchase price of the Accessory. The warranty period begins on the vehicle's In-Service Date, which is the first date the new vehicle is either delivered to an ultimate purchaser, leased, or used as a company car or demonstrator. Accessories installed by Southeast Toyota Distributors, LLC are identified on the vehicle's window sticker (Monroney Label).
- ii. **Accessories Installed by a Toyota Dealer on a Toyota vehicle.** We warrant that, for 12 months, regardless of mileage, from the date such an Accessory was installed on the vehicle or the remainder of the Toyota new vehicle warranty, whichever is longer, we will repair or replace (includes labor), free of charge, any defect in the Accessory due to faulty material or workmanship, or, at our option, provide a full refund of the purchase price of the Accessory. For a new vehicle, the warranty period begins on the vehicle's In-Service Date, which is the first date the new vehicle is either delivered to an ultimate purchaser, leased, or used as a company car or demonstrator.
- iii. **Accessories purchased from a Toyota Dealer but not installed by the Toyota Dealer.** We warrant that, for a period of 12 months, regardless of mileage, from the date the accessory was purchased, we will repair or replace (does not include labor), free of charge, any defect in the Accessory due to faulty material or workmanship, or, at our option, provide a full refund of the purchase price of the Accessory.

B. Limitation of Warranty. This limited warranty does not apply to, and we will not repair, replace, or reimburse you for: (1) wheel balancing and wheel alignments, except for one wheel balancing or alignment during the first 12 months or 12,000 miles, whichever occurs first, from the vehicle's In-Service Date, as defined above, (2) abrasions or dents, whatever their cause, and any failure or damage resulting directly or indirectly from accidents, collisions, impacts from foreign objects, fire, theft, larceny, explosion, malicious mischief, vandalism, civil commotion, riots, war, or any other similar causes, (3) any failure or damage resulting directly or indirectly from lightning, windstorms, hail, water, floods, subfreezing temperatures, airborne chemicals, tree sap, dust, salt, and any other environmental conditions or similar causes, (4) any failure or damage caused by: (a) a failure of any part, other than the Accessory, (b) any misuse, abuse, improper towing, negligence or lack of maintenance of the vehicle or Accessory, (c) the alteration, modification or repair of the Accessory by anyone other than persons expressly authorized by us to perform such alteration, modification or repair, or (d) the use of the vehicle for commercial purposes, competitive driving or racing, (5) any failure or damage, if the Accessory has not been installed according to instructions, (6) any failure or damage occurring outside of Canada, the United States of America, its territories or possessions, (7) except to the extent required by the state whose laws govern this limited warranty, any consequential, secondary, or unreasonable costs that may be suffered as a result of the need to repair or replace the Accessory, including without limitation any loss of use of the vehicle, road service, towing, storage charges, inconvenience, loss of wages and/or income, additional expense incurred, loss of transportation, rental car expense, or any derivative damage to persons or things other than the Accessory, including other parts of the vehicle, or (8) liability for damage to property or for injury to or death of any person, arising out of the operation, maintenance or use of your vehicle whether or not related to the covered Accessory.

C. Exclusive Remedy. If there is a valid claim under this limited warranty for a defect due to faulty material or workmanship in the Accessory, we will, at our option, either: (i) repair, (ii) replace or (iii) provide a full refund of the purchase price of the Accessory. We have no other obligations under this limited warranty. Refunds will be made to the vehicle owner. If the vehicle is leased, the refund will be made to the leasing company.

HOW TO MAKE A CLAIM: In the event of a warranty claim, please contact the nearest Toyota dealer to arrange for repairs. The dealership must receive our prior authorization before making repairs covered by this limited warranty. The dealer will contact Southeast Toyota Distributors, LLC at 1-888-851-2722, select option #5 (Warranty Department), then option #4 (Repairs), for instructions on processing a warranty claim, if they are not already familiar with the process. If you have any questions or concerns regarding repairs covered by this limited warranty, please contact our **Customer Assistance Hotline at 1-800-301-6859**.

OUR DISPUTE RESOLUTION PROGRAM: Your satisfaction is our highest priority. In keeping with that focus, in the event that an issue arises related to this Limited Warranty, we invite you to call our Customer Assistance Hotline at 1-800-301-6859 to discuss it. In most cases, we expect that a satisfactory resolution of your issue can be reached through engagement with that Department. If our Customer Loyalty Department is unable to resolve your issue to your satisfaction, we offer a dispute resolution program administered by the National Center for Dispute Settlement (NCDS) ("the Program"). The purpose of the Program is to resolve disputes in an informal setting before an impartial arbitrator. The Program is free of charge to you (although you must bear the cost of any expert witness or attorney you elect to employ). You are required to complete the Program before exercising rights or seeking remedies under the federal Magnuson-Moss Warranty Act, 15 U.S.C. § 2301 et seq. ("the Act"). If you choose to seek remedies that are not created by the Act, you are not required to use the Program before pursuing such remedies – although the Program is still available to you to resolve the dispute. When utilizing the Program, you will need to provide (a) the vehicle identification number of your vehicle, (b) the identity of your selling and servicing dealerships, (c) the mileage on your vehicle at relevant times, (d) the date and nature of any relevant repairs, (e) legible copies of repair orders and other relevant documents, (f) a summary of the unresolved issue and the requested action, and (g) your contact information. In most cases, the dispute resolution process under the Program will be completed within forty (40) days of your submission of your request and will consist of steps such as an initial eligibility determination, an opportunity for you and us to submit information in writing relating to your claim, an oral hearing, and a decision from the arbitrator. A decision will be binding on you only if you choose to accept it. You may submit a request to NCDS by telephone at their toll free number: (877)-276-8848 or in writing at P.O. Box 463196, Mt. Clemens, MI 48046. You may obtain additional information regarding the Program at www.ncdsusa.org. In the event that the NCDS does not exist or no longer handles disputes for us at the time that you seek to submit a request, you may contact our **Customer Assistance Hotline at 1-800-301-6859** to obtain current information about our dispute resolution programs.

GENERAL LIMITATION OF WARRANTY: THIS LIMITED WARRANTY IS IN LIEU OF ALL OTHER EXPRESS WARRANTIES OR LIABILITIES. IN NO EVENT SHALL WE BE LIABLE FOR ANY CONSEQUENTIAL OR INCIDENTAL DAMAGES FOR BREACH OF THIS OR ANY OTHER WARRANTY. SOME STATES DO NOT ALLOW THE EXCLUSIONS OR LIMITATIONS OF INCIDENTAL OR CONSEQUENTIAL DAMAGES, SO THE ABOVE INFORMATION OR EXCLUSION MAY NOT APPLY. NO EXPRESS WARRANTY OF FITNESS OR MERCHANTABILITY IS GRANTED BY THIS LIMITED WARRANTY. THERE ARE NO WARRANTIES WHICH EXTEND BEYOND THOSE DESCRIBED IN THIS DOCUMENT. ANY IMPLIED WARRANTIES, INCLUDING THE IMPLIED WARRANTY OF MERCHANTABILITY OR FITNESS FOR A PARTICULAR PURPOSE, WHICH MAY BE APPLICABLE BY OPERATION OF LAW SHALL BE LIMITED TO THE PERIOD OF THIS WRITTEN LIMITED WARRANTY. SOME STATES DO NOT ALLOW LIMITATIONS ON HOW LONG AN IMPLIED WARRANTY LASTS, SO THE ABOVE LIMITATIONS MAY NOT APPLY. THIS LIMITED WARRANTY PROVIDES SPECIFIC LEGAL RIGHTS, AND THERE MAY BE OTHER RIGHTS WHICH VARY FROM STATE TO STATE. ANY ACTION FOR BREACH OF ANY WARRANTY HEREUNDER, INCLUDING ANY IMPLIED WARRANTY OF MERCHANTABILITY, MUST BE BROUGHT WITHIN A PERIOD NOT EXCEEDING 12 MONTHS AFTER EXPIRATION OF THIS LIMITED WARRANTY. THE REMEDIES SPECIFIED HEREIN AND THOSE SPECIFIED BY APPLICABLE LAW ARE THE ONLY REMEDIES AVAILABLE. WE ASSUME NO OTHER OBLIGATION OR RESPONSIBILITY WITH REGARD TO THE ACCESSORY. WE NEITHER ASSUME, NOR AUTHORIZE ANYONE TO ASSUME FOR US, ANY ADDITIONAL LIABILITY IN CONNECTION HEREWITH.

GENERAL: This limited warranty describes the complete and exclusive rights that result from the purchase of Accessories. No oral representations or statements may be relied upon. This limited warranty may not be amended or modified, and additional rights may not be granted, unless in a written statement signed by one of our officers. This limited warranty shall be governed by the laws of the state where the vehicle is purchased, excluding laws concerning conflicts of law. We may delegate the performance of our duties and obligations and assign our rights and benefits hereunder. For inquiries regarding this limited warranty, we can be contacted directly at **Customer Assistance Hotline at 1-800-301-6859**, or by mail to: **Southeast Toyota Distributors, LLC, Attention: Customer Loyalty Department, 100 Jim Moran Boulevard, Deerfield Beach, Florida 33442.**