

Toyota

Prius

2010-

Interior Light Upgrade

Part Number 00016-00095

Accessory Code: IL2



Conflicts

--

Kit Contents

Item #	Quantity Req'd.	Description
1	1	"Y" Adapter
2	1	Wire harness
3	1	Hardware Kit
4	2	White Light Modules
5	1	Switch Kit
6	2	Amber cup holder kits
7	1	Customer Information card

Color Applicability/Trim Level

Accessory Color																				

Hardware Bag Contents

Item #	Quantity Req'd.	Description
1	4	Wire tie .0625
2	5	foam pads
3	2	T-Taps
4	4	Modules Screws

General Applicability

All models of Prius

Switch Bag Contents

Item #	Quantity Req'd.	Description
1	1	Switch
2	1	End Cap, Black
3	1	Illumination Nameplate
4	1	Installation tool
5	1	Bezel
6	1	Black spacer

Recommended Sequence of Application

Item #	Accessory	
1 *	Overlay	Apply any overlay first
2		
3		

*Mandatory

Recommended tools

Safety Tools	
Vehicle protection	
Safety glasses	
Special Tools	
Installation Tools	
Phillips screwdriver	1/4 inch jewelers
Torque wrench	48in. lbs
Nylon Removal Tool	
Pliers	
Diagonal cutter	or wire tie tool
Scissors	
Drill	
1/8" Drill bit	
1/2" Drill bit.	UniBit or step drill rec.
9/32" Drill bit	
Scribe or Center punch	
Masking tape	

Legend

 **STOP:** Damage to the vehicle may occur. Do not proceed until process has been complied with.

 **OPERATOR SAFETY:** Use caution to avoid risk of injury.

 **CAUTION:** A process that must be carefully observed in order to reduce the risk of damage to the accessory/vehicle and to ensure a quality installation.

 **TOOLS & EQUIPMENT:** Used in Figures calls out the specific tools and equipment recommended for this process.

 **REVISION MARK:** This mark highlights a change in installation with respect to previous issue.

 **SAFETY TORQUE:** This mark indicates that torque is related to safety.

SPECIAL NOTE:
 After **TMS** and **Safety** mandated preparatory steps have been taken, the installation sequence is the suggested method for completing the accessory installation. In some instances the suggested sequence is written for one associate to install and in others the sequence is given as part of a team accessory installation. Unless otherwise stated in the document, the associates may perform the installation steps in any order to make the installation as efficient as possible while maintaining consistent quality.

Table of Contents

I. Preparation 1-2
 1. Table Of Contents.....2
 II. Procedure.....3-9
 1. Vehicle Preparation.....3
 III. Checklist5
 1. Accessory Function Checks10
 2. Vehicle Function Checks.....10

Accessory Installation Practice (read before installation)

Care must be taken when installing this accessory to ensure damage does not occur to the vehicle. The installation of this accessory should follow approved guidelines to ensure a quality installation.

These guidelines can be found in the “Accessory Installation Practices” document.

This document covers such items as:

- Vehicle Protection (use of covers and blankets, cleaning chemicals, etc.)
- Safety (eye protection, checking torque procedure, etc.)
- Vehicle Disassembly/Reassembly (panel removal, part storage, etc.)
- Electrical Component Disassembly/Reassembly (battery disconnection, connector removal, etc.)

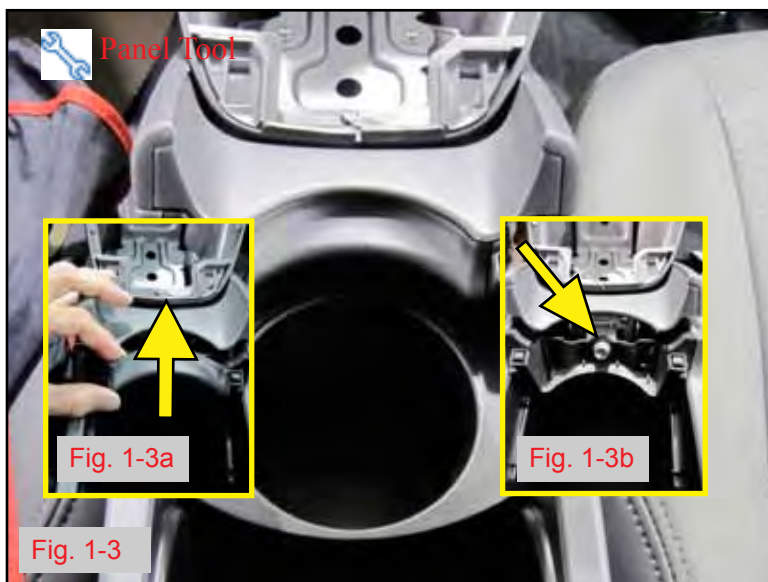
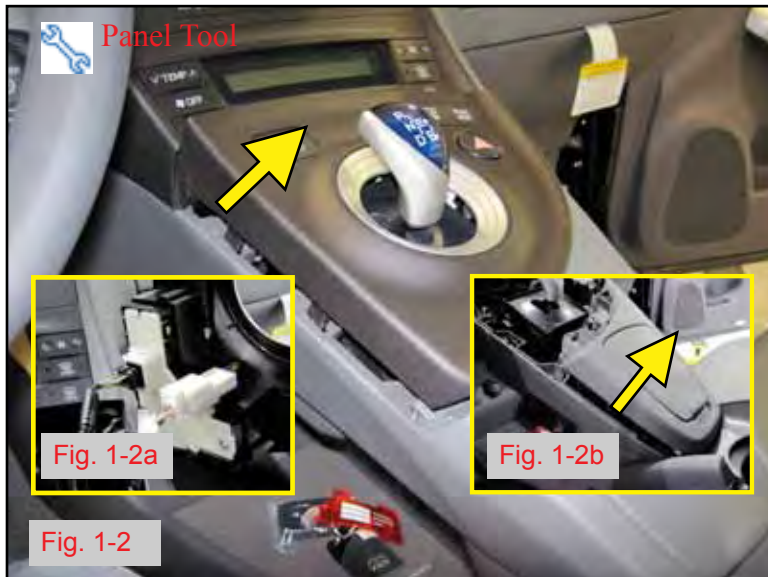
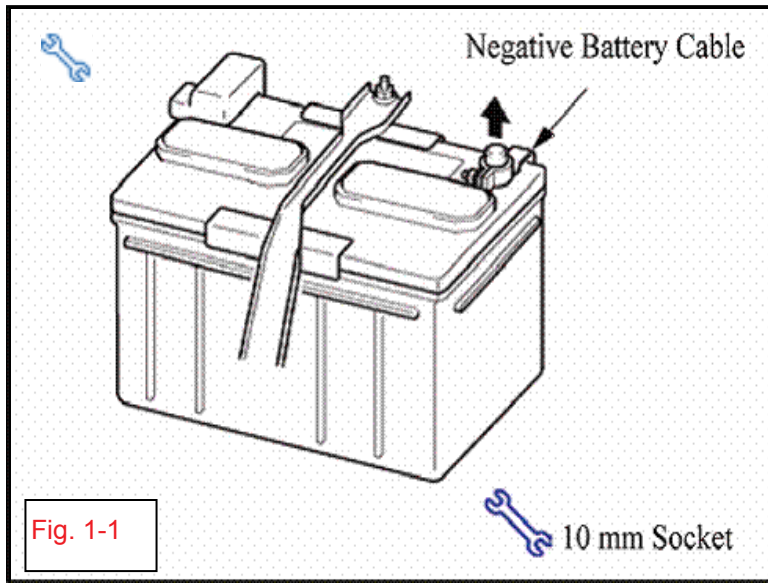

1. Check Kit Contents

- a. Check kit for content and damage.

2. Vehicle Preparation

- +** a. Apply protective covering to vehicle.
- !** b. Set parking brake.
- c. Open rear hatch.
- d. Lift trunk shelf to access battery.
- e. Remove battery negative terminal.
- +** f. Protect rear hatch entry before starting

CAUTION: do not touch the positive terminal with any tool during removal.

3. Remove Center Console

- a. Use panel safe tool.
- b. Pry around edge of shifter surround.
(Fig. 1-2)
- c. Lift shifter surround and disconnect cables, remove from vehicle. (Fig.1-2a)
- d. Pry around edge of cupholder assembly and remove from vehicle. (Fig. 1-2b)
- e. Open storage bin lid. (Fig. 1-3)
- f. Remove insert by sliding up to remove. (Fig. 1-3a)
- g. Remove bolt with 10mm socket. (Fig. 1-3b)

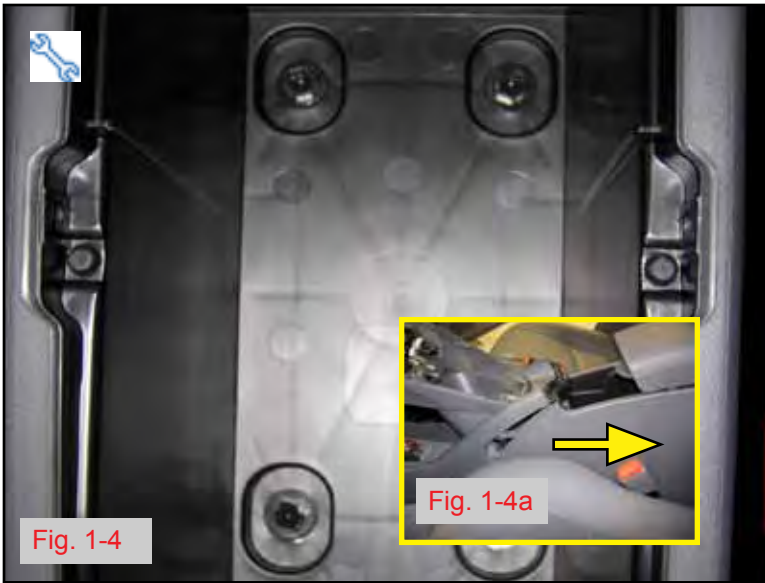

- h. Remove 4 bolts with 10mm socket. (Fig 1-4)
- i. Slide storage assembly towards rear of vehicle and remove. (Fig 1-4a)

4. Install Rear Storage Lights

- a. Drill holes for front storage box lights.
 - 1. Cut out enclosed paper template labeled “Rear Storage Lights”
 - 2. Remove cover by pulling straight back. (Fig. 1-5a)
 - 3. Orient rear storage box as shown. (Fig. 1-5)

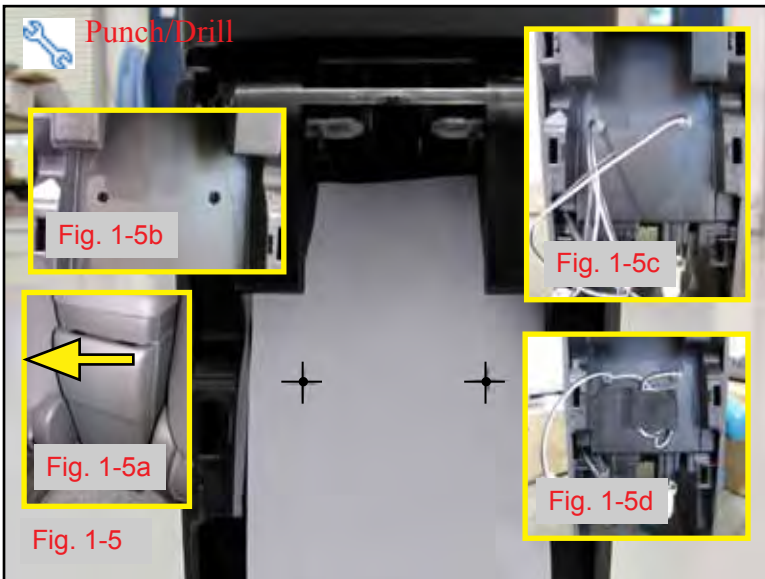

- 4. Use a punch/scribe to mark the center of the hole to be drilled. (Fig. 1-5)
- 5. Drill pilot holes with 1/8” drill bit.
- 6. Drill the lamp hole with a 9/32” drill bit. (Fig. 1-5b)
- 7. De-burr holes with de-burring tool. Install lens from inside of cup holder.
- b. Insert Lens from inside of storage box.
- c. Firmly press body of lamp onto lens. (Fig. 1-5c)
- d. Secure excess wire with foam pad and place aside. (Fig. 1-5d)

5. Install Rear Lower Arch Light

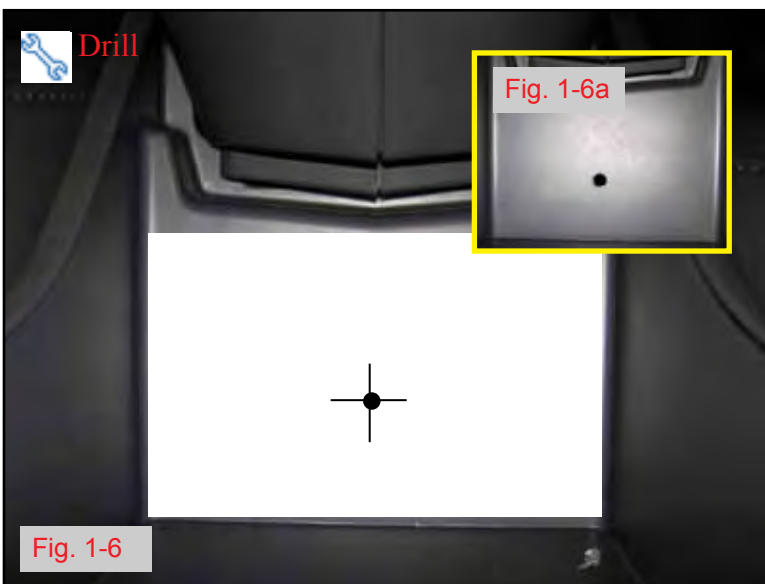

- a. Cut out enclosed paper template labeled “Rear Lower Arch Light” (Fig. 1-6)
- 1. Use a punch/scribe to mark the center of the hole to be drilled.
- 2. Drill pilot holes with 1/8” drill bit.
- 3. Drill the lamp hole with a 9/32” drill bit. (Fig. 1-6a)
- 4. De-burr holes with de-burring tool.
- b. Insert Lens from inside arch.
- c. Use pliers to gently hold lamp.

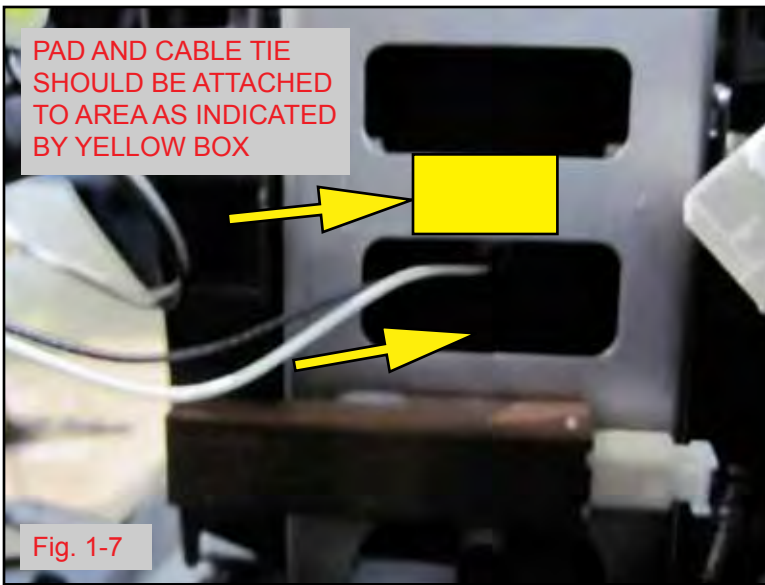

- d. Slide lamp between metal stamping as shown. (Fig. 1-7)
- e. Firmly press body of lamp onto lens.
- f. Secure lamp leads.
 1. Using foam pads and cable ties, secure lamp leads to partition wall. (Fig. 1-7)

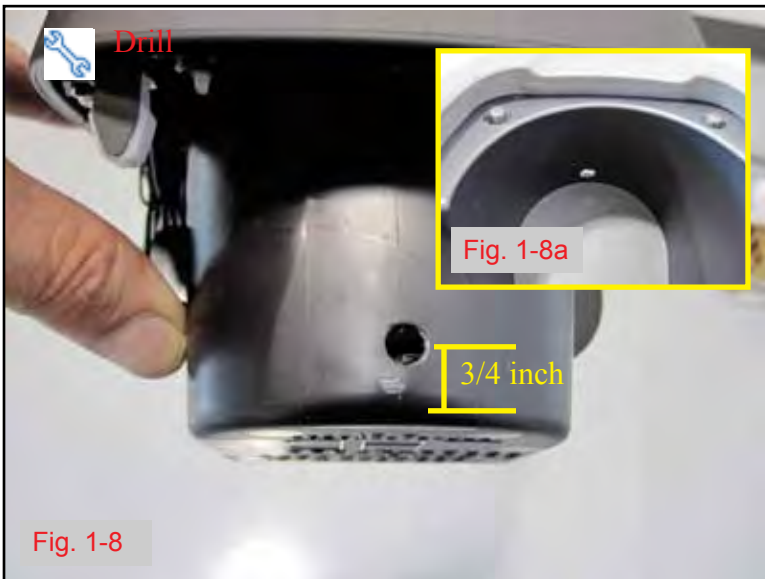

6. Drill Hole for Center Console Cupholder Light

- a. Drill hole for center console light
 1. Visually locate center rear of cupholder in previously removed center console cupholder insert. (Fig. 1-8)
 2. hole center should be 3/4" above bottom. Finished assembly will appear as shown. (Fig. 1-8a)
 3. Use a punch or scribe to mark center of the hole to be drilled. (Fig. 1-8)
 4. Drill pilot holes with 1/8" drill bit.
 5. Drill the lamp hole with a 9/32" drill bit. (Fig.1-8)





- b. Light will be installed after cup holder assembly is reinserted. See section 12.

7. Install Power Switch

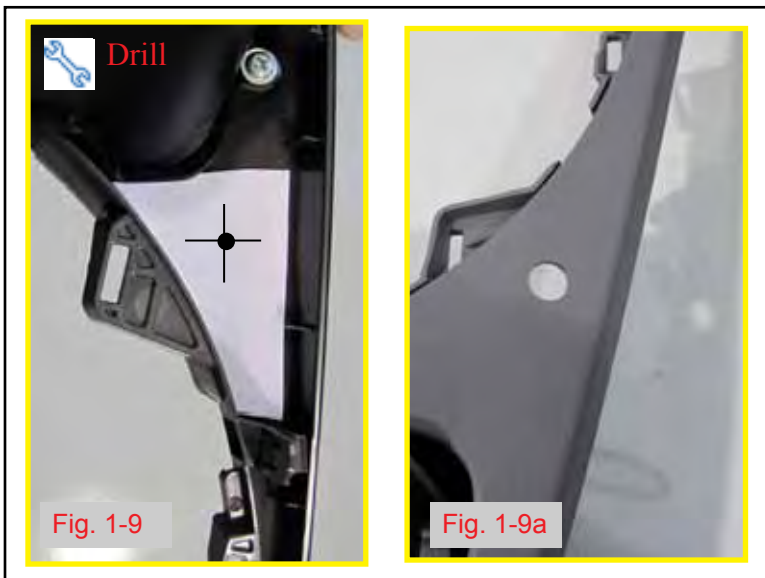
- a. Drill hole for switch
 1. Cut out enclosed paper template labeled "Power Switch"
 2. Use a punch or scribe to mark center of the hole to be drilled. (Fig. 1-9)
 3. Using a 1/2" drill bit (Unibit or step drill is highly recommended), drill the switch hole. (Fig. 1-9a)

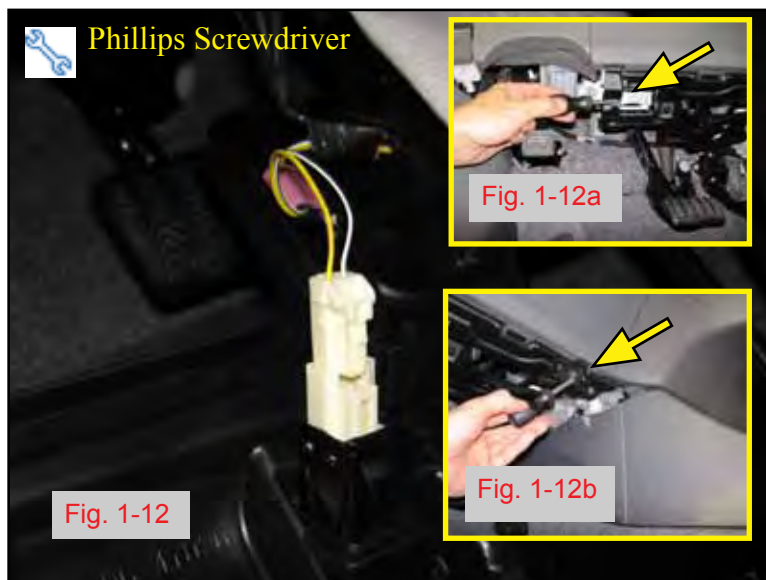



- b. Clean bezel surface to remove grease and wax.
 - 1. Wipe the application area clean with alcohol and a clean no-scratch cloth.
-  2. Dry the installation area using a clean, dry, lint free cloth.
- c. Insert switch bezel into switch plate. (Fig. 1-10a)
- d. Using the pull-tab, remove the tape liner from the back of the switch plate. (Fig. 1-10b)
 - 1. Avoid finger contact with the adhesive surface.
- e. Using the bezel as a guide, install switch plate into the previously drilled 1/2" hole.
 - 1. Align the printing "ILLUMINATION" square to the console. (Fig. 1-11)
 -  2. Once aligned, press down firmly to adhere tape.
- f. Install Sleeve to bezel, white edge of sleeve goes towards console. (Fig. 1-10c)
- g. Install switch to bezel.
 - 1. Using switch tool turn bezel clockwise to tighten.
 - 2. Be careful not to over tighten as this will "over ride" the threads on the switch. If this happens simply retighten being careful not to over tighten.
 - 3. Push button into bezel pressing to engage. (Fig. 1-11)

8. Install light modules

- a. Install Driver side Light Module.
- b. Remove screws securing shield (Fig. 1-12a-b)



- c. Lower shield and disconnect lead. (Fig. 1-12)
- d. Locate attachment location indicated by arrow. (Fig. 1-13)
- e. Clean surface to remove and wax.
- f. Wipe application area clean with alcohol and a clean no-scratch cloth. (Fig. 1-14a)
- g. Dry the installation area using a clean, dry, lint free cloth.
- h. Using the pull tab remove the tape liner from the back of the switch plate. (Fig. 1-14b)
- i. Avoid finger contact with the adhesive surface.
 - 1. Press module firmly against surface.
- j. Secure module with screws. (Fig. 1-14c)
- k. Install passenger side Light Module.
- l. Remove under dash shroud by pressing tabs located below glove box. (Fig. 1-15a)
- m. Install Light Modules
- n. Locate attachment location indicated by arrow. (Fig. 1-15)
- o. Repeat steps (1-14a through 1-14c)
- p. Thread pigtail through slot in shield indicated by arrow (Fig. 1-15)

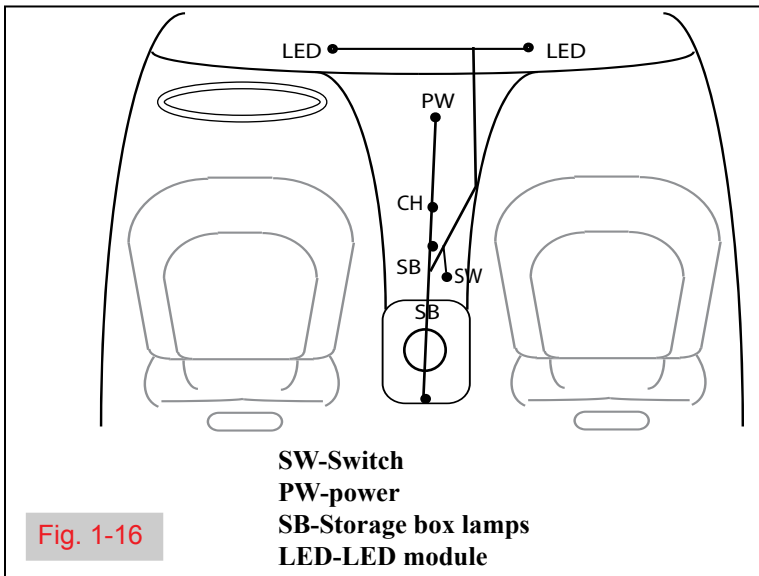

Fig. 1-16

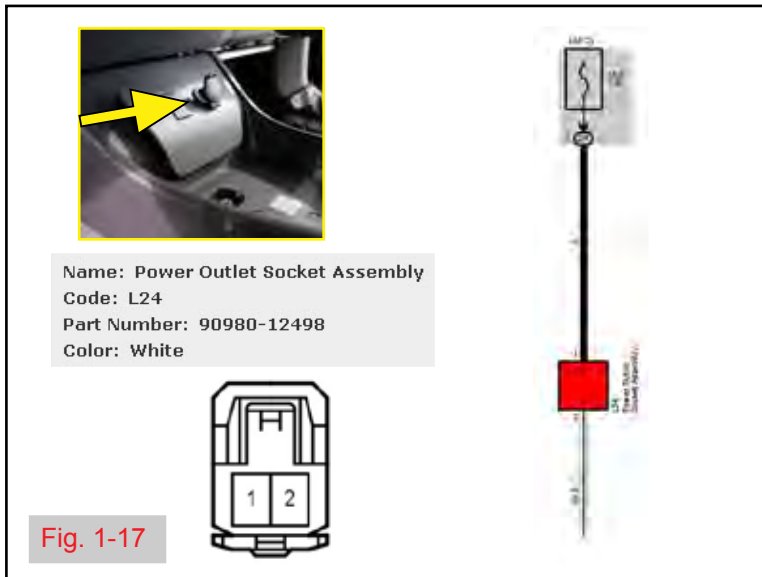

Fig. 1-17

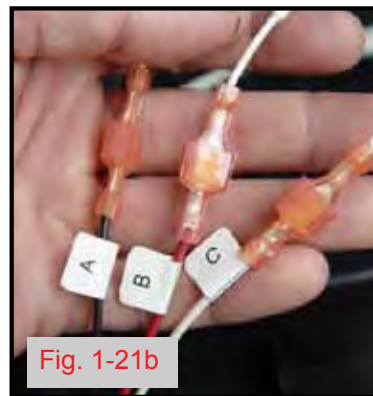
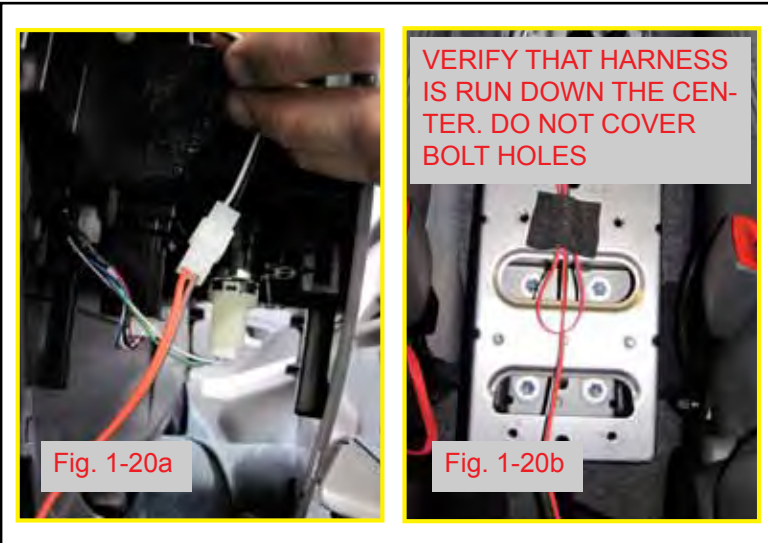

Fig. 1-18

9. Install Harness

CAUTION: Secure harness with pads and cable ties as needed, keep harness from touching hot or moving objects.

- a. Lay out harness as shown and identify connectors. (Fig.1-16)
- b. Bulk of harness will reside ahead of to the passenger side of the center console.
- c. Remove forward kick panel to aid in harness installation. (Fig. 1-20a,b)
- d. Route Light module connector forward and behind kick panels.
- e. Repeat on passengers side
- f. Connect Light module connectors to previously Light module.
- g. Locate auxillary power outlet.
- h. Remove panel (Fig. 1-17)
 1. Install T-taps in staggered fashion. (Fig. 1-18)
- i. Attach harness to power.
 1. Black wire on harness to white/black wire on power outlet socket.
 2. White wire on harness to gray wire on power outlet socket.
 3. Route harness
 4. Remove forward kick panel to aid in harness installation. (Fig. 1-19a,b)
- j. Secure harness using cable ties.
 1. Verify that no moving parts will rub on the harness.
 2. Route harness towards rear and tuck under passenger side of center console. (Fig.1-19c)
- k. Secure any excess wire with cable ties and foam pads.
 1. Reinstall center console storage box.
 1. Attach “Y” connector to harness.



(Fig. 1-20a)

2. Attach “Y” connector to cup holder lamps.
3. Attach “Y” connector to front storage box lamps.
4. Secure harness with foam pad (Fig. 1-20b)
- m. Connect Switch to Harness.
- n. Lay insert on passenger side seat. (Fig. 1-21a)
- o. Connect leads being careful verify labels. (Fig. 1-21b)
 1. Reinstall insert.
- p. Place operators card in storage box.

10. Reinstall rear storage box

- a. Place storage box in vehicle and carefully slide forward making sure plastic fingers engage correctly. (Fig. 1-22a)
- b. Secure four bolts with 10mm wrench.

11. Install Cup Holder insert

- a. Reinstall cup holder insert. (Fig. 1-22b)
- b. Insert Lens from inside cup holder.
- c. Firmly press body of lamp onto lens.

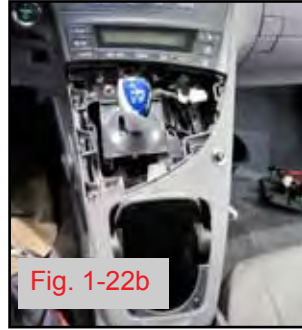

12. Complete installation

- a. Reinstall auxiliary power assembly.
 - b. Reinstall shift surround.
 - c. Reinstall interior.
 - d. Re-attach negative battery terminal, torque to 48 inch pounds.
- Place information card in glove box.

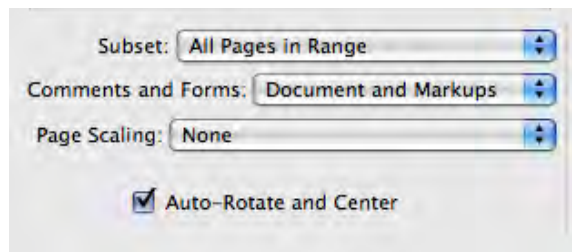

If printing this document select "none" for PAGE SCALING or templates will not print to the correct size.

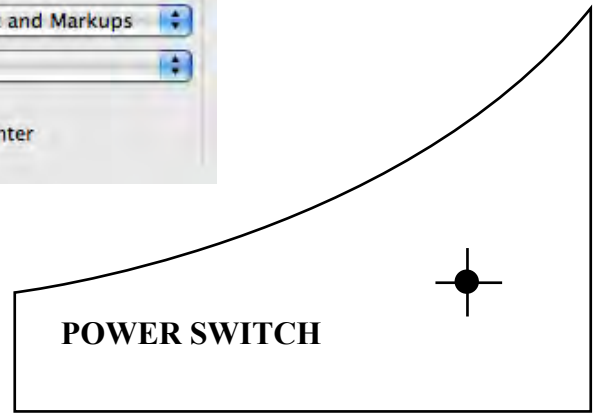

2 inches

