

**Toyota**

**Camry**

**2011-**

**Interior Light Upgrade**

**Part Number 00016-00095**

**Accessory Code: IL2**



**Conflicts**

--

**Kit Contents**

Item #	Quantity Req'd.	Description
1	1	"Y" Adapter
2	1	Wire harness
3	1	Hardware Kit
4	2	White Light Modules
5	1	Switch Kit
6	2	Amber cup holder kits
7	1	Customer Information card

**Color Applicability/Trim Level**

Accessory Color																				

**Hardware Bag Contents**

Item #	Quantity Req'd.	Description
1	4	Wire tie .0625
2	5	foam pads
3	2	T-Taps
4	4	Modules Screws

**General Applicability**

All models of Camry
---------------------

**Switch Bag Contents**

Item #	Quantity Req'd.	Description
1	1	Switch
2	1	End Cap, Black
3	1	Illumination Nameplate
4	1	Installation tool
5	1	Bezel
6	1	Black spacer

**Recommended Sequence of Application**

Item #	Accessory	
1 *	Overlay	Apply any overlay first
2		
3		

**Legend**

\*Mandatory

 **STOP:** Damage to the vehicle may occur. Do not proceed until process has been complied with.

 **OPERATOR SAFETY:** Use caution to avoid risk of injury.

 **CAUTION:** A process that must be carefully observed in order to reduce the risk of damage to the accessory/vehicle and to ensure a quality installation.

 **TOOLS & EQUIPMENT:** Used in Figures calls out the specific tools and equipment recommended for this process.

 **REVISION MARK:** This mark highlights a change in installation with respect to previous issue.

 **SAFETY TORQUE:** This mark indicates that torque is related to safety.

**Recommended tools**



<b>Safety Tools</b>	
Vehicle protection	
Safety glasses	
<b>Special Tools</b>	
Installation Tools	
Phillips screwdriver	1/4 inch jewelers
Torque wrench	36in. lbs
Nylon Removal Tool	
Pliers	
Diagonal cutter	or wire tie tool
Scissors	
Drill	
1/8" Drill bit	
1/2" Drill bit.	UniBit or step drill rec.
9/32" Drill bit	
Scribe or Center punch	
Masking tape	

**SPECIAL NOTE:**  
 After **TMS** and **Safety** mandated preparatory steps have been taken, the installation sequence is the suggested method for completing the accessory installation. In some instances the suggested sequence is written for one associate to install and in others the sequence is given as part of a team accessory installation. Unless otherwise stated in the document, the associates may perform the installation steps in any order to make the installation as efficient as possible while maintaining consistent quality.

**A. Check Kit Contents**

1. Check kit for content and damage. (Fig. A1)

**B. Vehicle Preparation**

-  1. Remove battery negative terminal.
-  2. Apply protective covering to vehicle

**C. Remove center console**

1. Place shifter in "2-L" position.
  -  i. Set parking brake.
  - ii. Use panel safe tool.
  - iii. Remove cover. (Fig. C1)
  - iv. Depress interlock and place shifter in "2-L" position.
  - v. Turn shift knob counter clockwise and remove. (Fig. C2)
2. Remove center console bezel.
  - i. Use panel safe tool.
  - ii. Remove trim pieces on either side of of center console. (Fig. C3)
  - iii. Carefully pry around bezel. (Fig. C4).
  - iv. Lift partially, disconnect power lead, and remove from vehicle. (Fig. C5)
3. Remove center console storage box.
  - i. Remove felt insert.
  - ii. Remove (2) 10mm bolts. (Fig. C6)
  - iii. Remove (2) screws. (Fig. C7)
4. Lift forward edge of console to disengage fingers and lift partially.
  - i. Release cable clamp. (Fig. C8)
  - ii. Remove center console from vehicle.

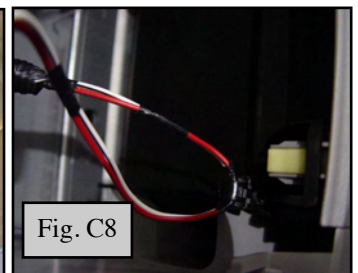
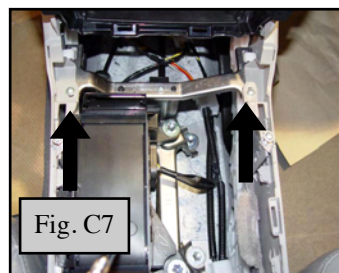
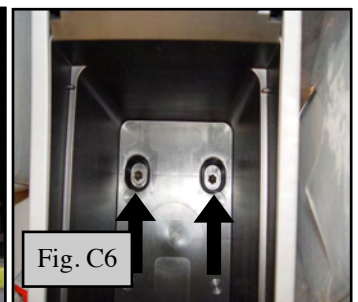
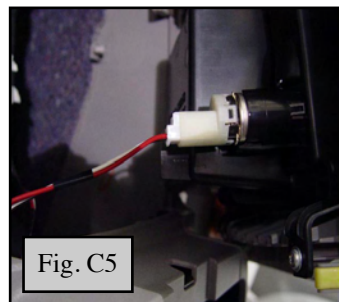
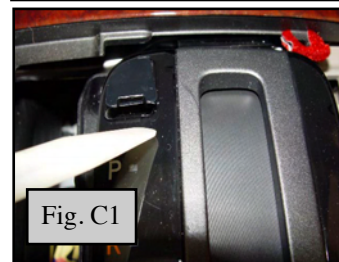

**D. Install Cup holder Lights**

1. Orient cup holder assembly as shown. (Fig. D1)
2. Drill holes for cup holder lights.
  - i. Cut out enclosed paper template labeled “Camry cup holder ”.
  - ii. Align template as shown use a punch/scribe to mark the center of the hole to be drilled. Place template so holes will be oriented “inward” (Fig. D2)
  - iii. Drill pilot holes with 1/8” drill bit.
  - iv. Finally drill hole with a 9/32” drill bit. (Fig. D3)
  - v. De-burr holes with de-burring tool.
3. Insert Lens from inside of cup holder. (Fig. D4)
4. Firmly press LED assembly into lens. (Fig. D5)
5. Use adhesive pad to secure wires. (Fig. D6)

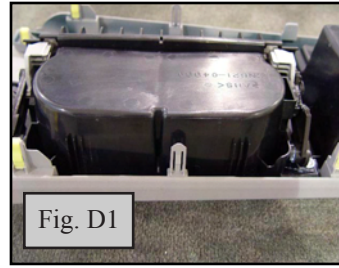

Fig. D1

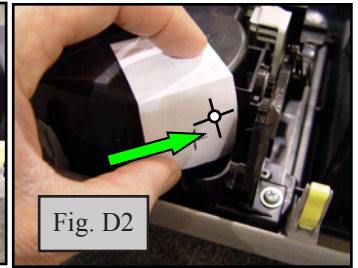

Fig. D2

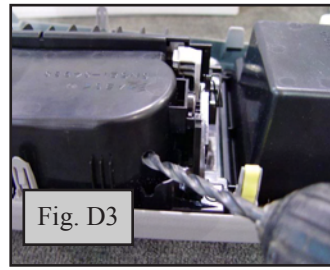

Fig. D3

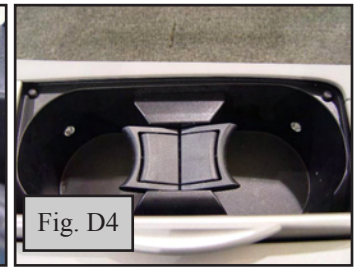

Fig. D4

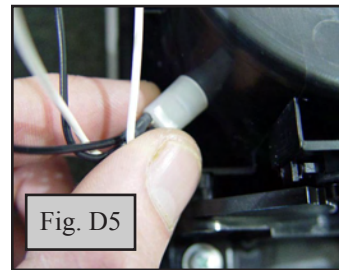

Fig. D5

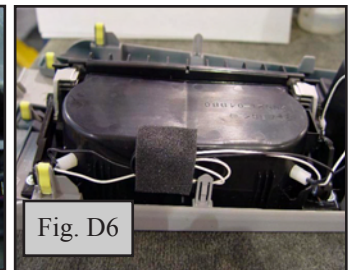

Fig. D6

**E. Install Storage Box Lights.**

1. Drill holes for LEDs
  - i. Cut out “Camry storage box” template.
  - ii. Align template as shown using castings on either side for alignment then center. (Fig. E1)
  - iii. Use a punch/scribe to mark the center of the hole to be drilled.
  - iv. Drill pilot holes with 1/8” drill bit.
  - v. Drill the lamp hole with a 9/32” drill bit.
  - vi. De-burr holes with de-burring tool.
2. Insert lens from inside storage box. (Fig. E2)
3. From the back of the storage box, install the LED’s onto the lenses. Press firmly while holding the Lens from the inside. Secure with foam pad. (Fig. E3)
4. Use adhesive pad to secure wires. (Fig. E4)

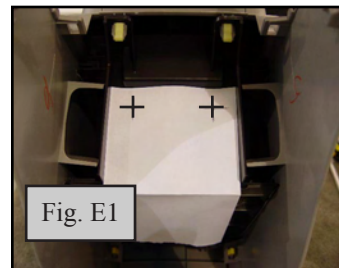

Fig. E1

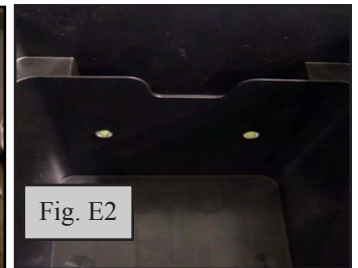

Fig. E2

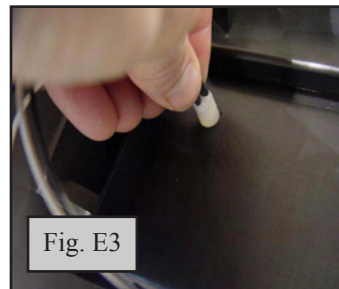

Fig. E3

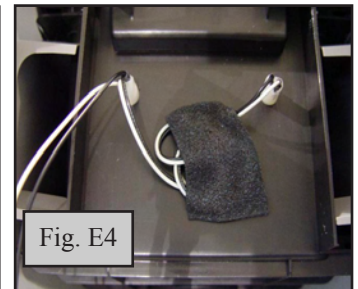
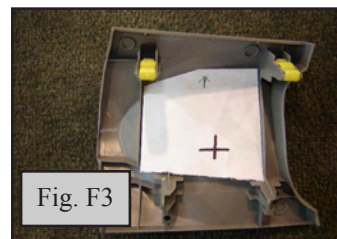
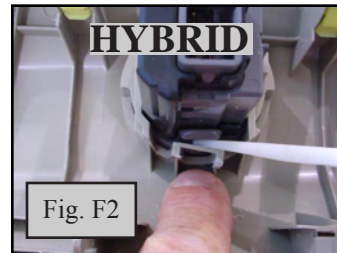
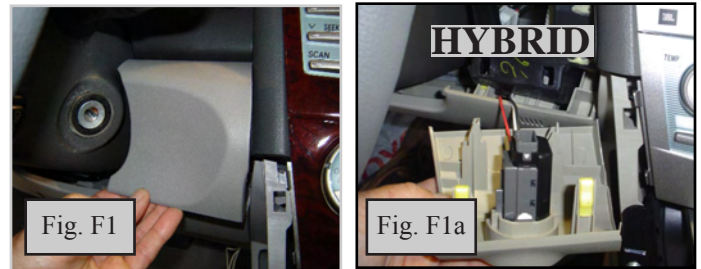

Fig. E4

Section II - Installation Procedure

**F. Install power Switch**

1. Remove insert to right of steering column., disconnect lead on hybrid. (Fig. F1)
2. Release on switch to facilitate drilling. (Fig. F2)
3. Drill hole for switch.
  - i. Cut out enclosed paper “Camry switch” template.
  - ii. Place template so hole drilled will be oriented as pictured. (Fig. F3)
  - iii. Use a punch or scribe to mark center of the hole to be drilled.
  - iv. Using a 1/2” drill bit (Unibit or step drill is highly recommended), drill the switch hole.
4. Clean bezel surface to remove grease and wax.
  - i. Wipe the application area with alcohol/water and a clean dry cloth.
  - ii. Dry the installation area using a clean, dry, lint free cloth.
5. Insert switch bezel into switch plate. (Fig. F4)
6. Using the pull-tab, remove the tape liner from the back of the switch plate. (Fig. F5)
  - i. Avoid finger contact with the adhesive surface.
7. Using the bezel as a guide, install switch plate/bezel into the previously drilled 1/2” hole.
  - i. Align the printing “ILLUMINATION” square to the console. (Fig. F6)
  - ii. Once aligned, press down firmly to adhere tape.
8. Install Sleeve to bezel, white edge of sleeve goes towards console. (Fig. F7)
9. Install switch to bezel as shown.
  - i. Using switch tool turn bezel clockwise to tighten.
  - ii. Be careful not to over tighten as this will “over ride” the threads on the switch. If this happens simply retighten being careful not to over tighten.
  - iii. Push button into bezel pressing to engage. (Fig. F8)



**REAR VIEW OF HYBRID SWITCH INSTALL**



**G. Install Light Modules**

1. Install Driver side Light Module.
2. Locate attachment location as indicated. (Fig. G1-G2)
3. Light module will be attached to air duct facing the front of the vehicle. (Fig. G3)
3. Clean surface to remove and wax.
  - i. Wipe application area clean with alcohol and a clean no-scratch cloth.(Fig. G4)
  - ii. Dry the installation area using a clean, dry, lint free cloth.
4. Using the pull tab remove the tape liner from the back of the switch plate. (Fig. G5)
  - i. Avoid finger contact with the adhesive surface.
  - ii. Press module firmly against surface.
5. Secure module with screws. (Fig. G6)
6. Install passenger side Light Module.
7. Remove passenger side shield by pressing in four tabs located along front edge of shield. (Fig. G7)
8. Locate attachment location indicated by arrow. (Fig. G8)
9. Repeat steps G4 through G6.

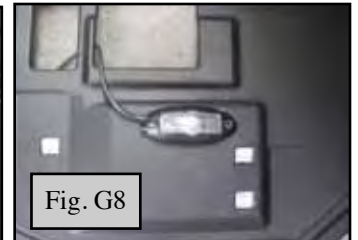
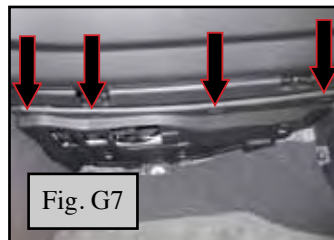

## H. Install harness

**CAUTION:** Secure harness with pads and cable ties as needed, keep harness from touching hot or moving objects.

1. Lay out harness as shown and identify connectors. (Fig. H 1)
2. Bulk of harness will reside under center console inlay
3. Remove upper panel sub-assembly. (Fig. H2)  
Disconnect wires behind panel
4. Locate power.
  - i. Locate auxiliary power connector that was disconnected behind upper panel sub-assembly.
  - ii. Install T-taps in staggered fashion. (Fig. H3)
5. Reinstall lower half of center console.
  - i. Slide console into locking fingers located towards front.
  - ii. With 10mm socket reinstall (2) bolts. (Fig. H4)
  - iii. Reinstall (2) screws on either side towards front. (Fig. H5)
6. Attach harness to power. (Fig. H6)
  - i. Black wire on harness to wt/blk wire, connector E35 pin 2.
  - ii. White wire on harness to red wire connector E35 pin 1.
7. Attach "Y" adapter to main harness. (Fig. H7)
8. Attach "Y" adapter to rear storage lights. (Fig. H8)
9. Attach "Y" adapter to cup holder lights. (Fig. H9)
10. Bundle excess wire and secure in center of console, reinstall cup holder assembly. (Fig. H10)
11. Secure harness to center console with foam pad. (Fig. H 11)
12. Re-install upper panel sub-assembly & re-connect wires.

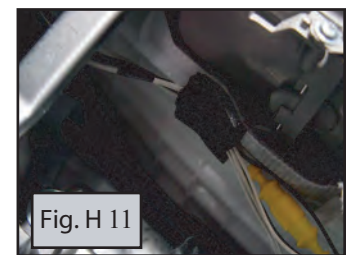
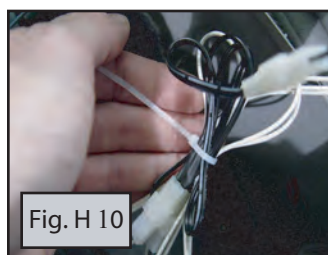
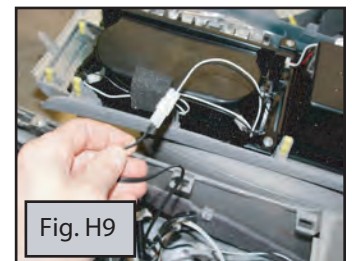
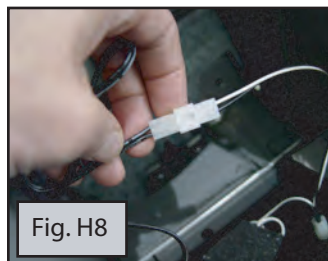
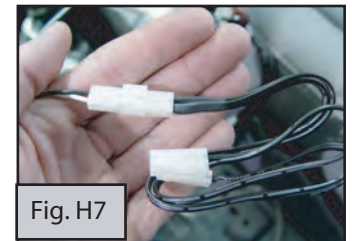
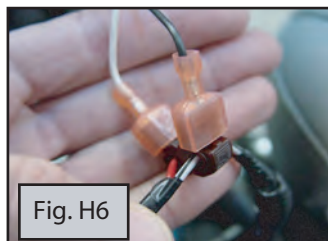
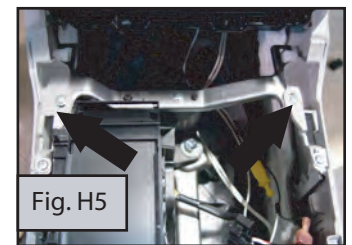
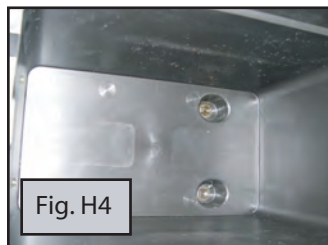
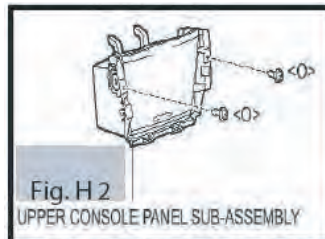
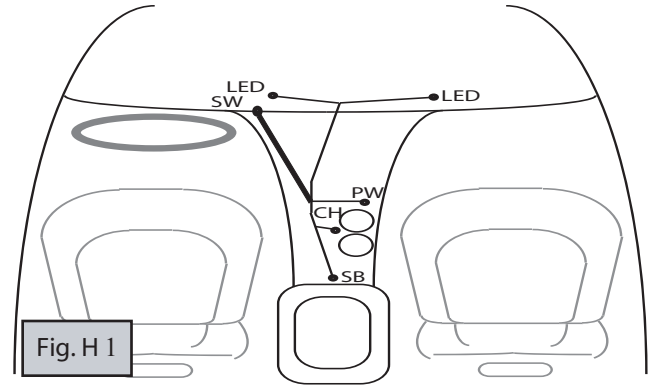

Section II - Installation Procedure

13. Route Switch leads forward and to the left of the center console. (Fig. H11)
14. Thread wire up and behind knee bolster. Route switch leads as shown. (Fig. H13)
15. Connect leads to switch assembly. (Fig. H14)
  - i. Reinstall trim piece. (Fig. H15)
  - ii. Reinstall trim piece, hybrid. (Fig. H15a)
16. Reinstall shift surround bezel.
  - i. Reconnect auxiliary power connector. (Fig. H16)
17. Firmly press shift surround into place.
18. Reinstall left and right trim pieces (Fig. H17)
19. Reinstall shift knob. (Fig. H18)
20. Attach harness to LED modules.
  - i. Attach left side LED module to harness. (Fig. H19)
  - ii. Attach right side LED module to harness. (Fig. H20)

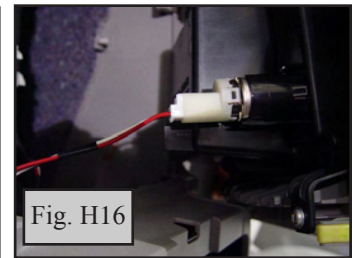
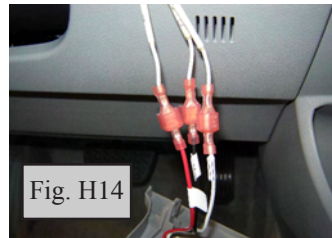
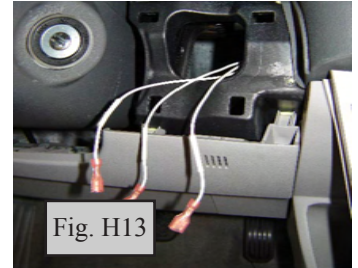
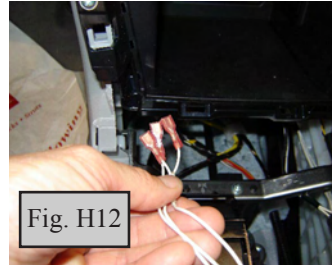

**I. Post Installation**

1. Reinstall interior.
2. Re-attach negative battery terminal, torque to 36 inch pounds.
3. Clean LED modules0
4. Cycle test the system with the key in the ACC or ON position. The cycle may start from any step below but should cycle in this order.
  - i. All lights off.
  - ii. Cup holder lights on only.
  - iii. All lights on.
  - iv. Interior Light on only.
  - v. Back to step “i”.
5. The switch should be cycled to step “i” (all lights off) for shipment.
6. Place information card in glove box.

Check:

\_\_\_\_\_

Single Unoperational Module

No Operational Modules

Look for:

\_\_\_\_\_

Full engagement of affected LED module to LED wire harness pigtail connector.

Full engagement of all LED module to LED wire harness pigtail connectors.

Power connection.

Ground connection

Switch connections

Blown light kit fuse. (2 amp located under center console)

Blown shift console illumination fuse (see vehicle owners manual for amperage and location.).

**VEHICLE FUNCTION CHECK**

AFTER ALL PANELS, COVERS, AND COMPONENTS HAVE BEEN REINSTALLED, THAT WERE REMOVED, TEST THOROUGHLY, ALL MECHANICAL AND ELECTRICAL COMPONENTS DISCONNECTED AND OR REMOVED FROM THE VEHICLE DURING THE INSTALLATION OF THIS ACCESSORY.



**CAMRY SWITCH TEMPLATE**

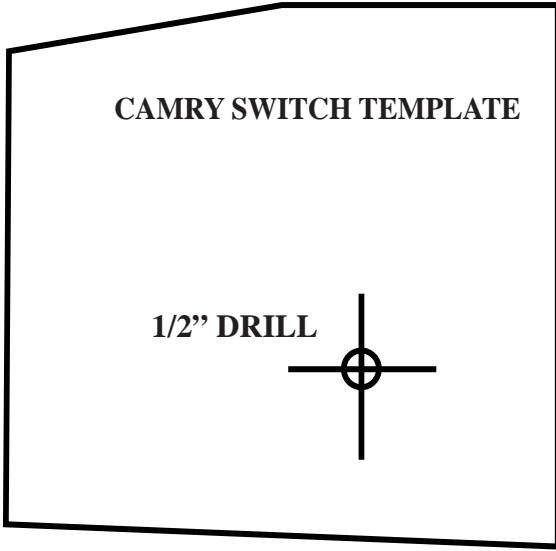

**CUP HOLDER TEMPLATE**

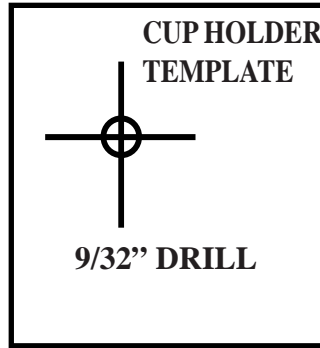

**STORAGE BOX TEMPLATE**

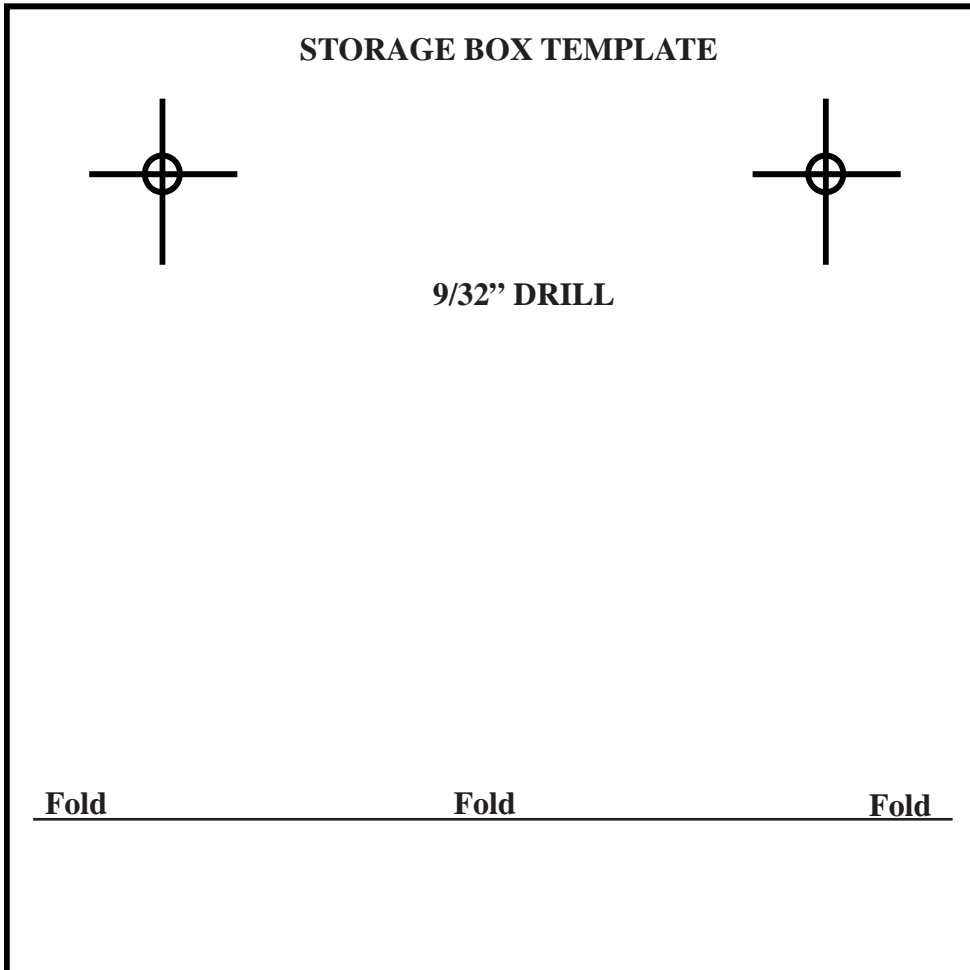

**HYBRID CAMRY SWITCH TEMPLATE**

