

TOYOTA

TUNDRA

2016

LED Fog Light & DRL 2in1

Part Number: 00016-00081

Accessory Code: LD4010



**Conflicts**

- Vehicles w/o factory fog light / Blind spot Monitor
---

**Kit Contents**

Item #	Quantity Reqd.	Description
1	2	Fog + DRL Housings
2	1	DRL Driver Box
3	1	DRL Harness Bag
4	1	DRL User's Card
5	1	DRL Switch

**Hardware Bag Contents**

Item #	Quantity Reqd.	Description
1	1	Hood Wire harness
2	1	Cabin Wire harness
3	1	Relay
4	25	Wire ties
5	1	14" wire tie
6	2	Black T-Taps

**Additional Items Required For Installation**

Item #	Quantity Reqd.	Description

**Recommended Tools**

<b>Safety Tools</b>	
Safety Glasses	
Electrical Tape	
<b>Installation Tools</b>	
10mm Wrench	
Phillips Screw Driver	
Nylon Pry Tool	
Torque Wrench	48 in-lb
Side Cutters	
<b>Special Chemicals</b>	
3M Silicon Sealant	

**Accessory Service Parts**

Service Part Part Number	DRL + Fog Housing LH	DRL + Fog Housing RH	DRL Switch	DRL Wire Harness	DRL Driver Box	DRL Relay
	00016-00081-01	X				
00016-00081-02		X				
00016-32270-05			X			
00016-32270-03				X		
00016-32270-06					X	
00016-32260-04						X

**General Applicability**

Models:
---------

**Recommended Sequence of Application**

Item #	Accessory
1	Paint Protection
2	DRL
3	Fender Flare

Mandatory Legend

**STOP:** Damage to the vehicle may occur. Do not proceed until process has been complied with.

**OPERATOR SAFETY:** Use caution to avoid risk of injury.

**CAUTION:** A process that must be carefully observed in order to reduce the risk of damage to the accessory/vehicle and to ensure a quality installation.

**TOOLS & EQUIPMENT:** Used in Figures calls out the specific tools and equipment recommended for this process.

**REVISION MARK:** This mark highlights a change in installation with respect to previous issue.

**SAFETY TORQUE:** This mark indicates that torque is related to safety.

**SPECIAL NOTE:**  
 After TMS and Safety mandated preparatory steps have been taken, the installation sequence is the suggested method for completing the accessory installation. In some instances the suggested sequence is written for one associate to install and in others the sequence is given as part of a team accessory installation. Unless otherwise stated in the document, the associates may perform the installation steps in any order to make the installation as efficient as possible while maintaining consistent quality. Also some items listed to be removed may not need to be removed if caution is taken to not damage vehicle.

Care must be taken when installing this accessory to ensure damage does not occur to the vehicle. The installation of this accessory should follow approved guidelines to ensure quality installation. These guidelines can be found in the Accessory Installation Practices document.

This document covers such items as:

- Vehicle Protection (use of covers and blankets, cleaning chemicals, etc)
- Safety (eye protection)
- Vehicle Disassembly / Reassembly (panel removal, part storage, etc)

## Preparation



Remove negative battery cable



## Installation

1. From front of vehicle, lay the DRL's wire harness on the engine compartment, left side from the battery towards the firewall of the car (pictures 1 and 1A).



Picture 1

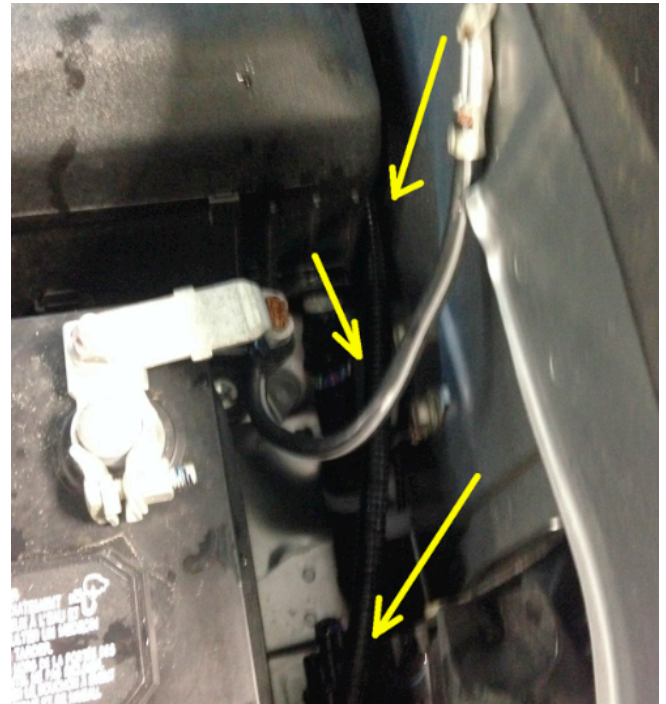

Picture 1B

2. Locate the large vehicle harness grommet on the left side. If accessible, cut the auxiliary wiring access nipple off the grommet or cut 1/4" slit in grommet and push the red, black, black-white and red-white wires through firewall. Note: Extra caution should be taken not to damage the connector's pin. Seal with 3M Silicone sealant (picture 2)

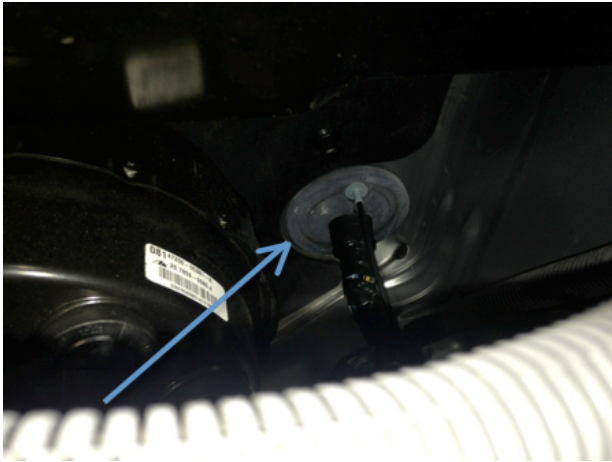

Picture 2

**Vehicle Disassembly**

- 3. Remove driver side door scuff plate. Disengage with panel tool and remove (picture 3 and 3A)

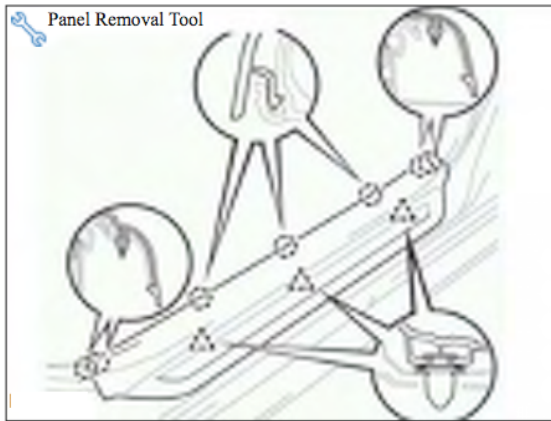

Picture 3



Picture 3A

- 4. Remove the driver side cowl side trim (pictures 4 and 4A)

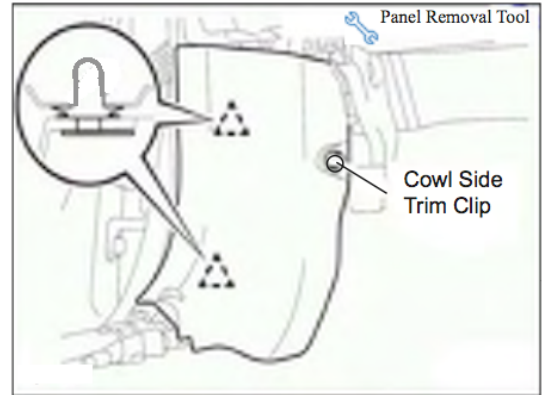

Picture 4



Picture 4A

- 5. Remove the driver's side lower dash panel: remove two lower screws (picture 5)



Picture 5

- 6. From inside the cabin, locate the wires that were pushed through in step 2. It will be the grommet left of the emergency brake (picture 6)





Picture 6

7. Route the wire harness to reach the left area of the steering wheel
8. Push the pins into the connector supplied in kit. The plastic connects have a mark with a positive (+) and a negative (-) symbol. Push the red wires into the "+" symbol and the black wires into the "-" symbol (picture 7)

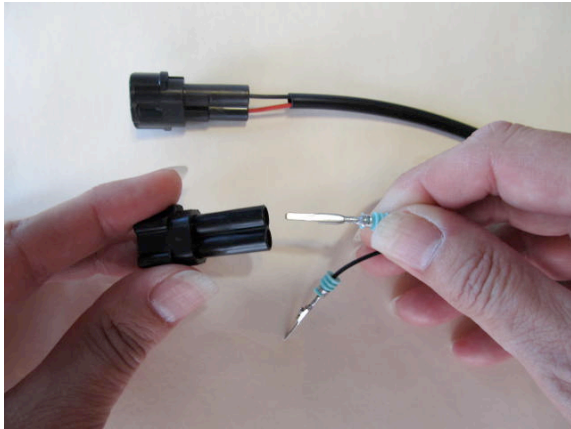

Picture 7

9. Connect the driver box to the wires pushed into the connectors on step 8 (make sure wire colors are aligned: black with black and red with red).
10. Using a 14" wire tie, secure the driver box to the back side the factory harness by the kick panel (picture 8).



Picture 8

11. Install a black T-tap to connector J130 pin 8, light green wire. J130 is located on the back of the power mirror control switch. Then connect the red wire from DRL harness to the t-tap (pictures 9, 9A and 9B).

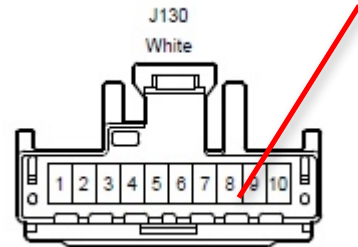

Picture 9: DRL red wire to connector J130 (light green wire)

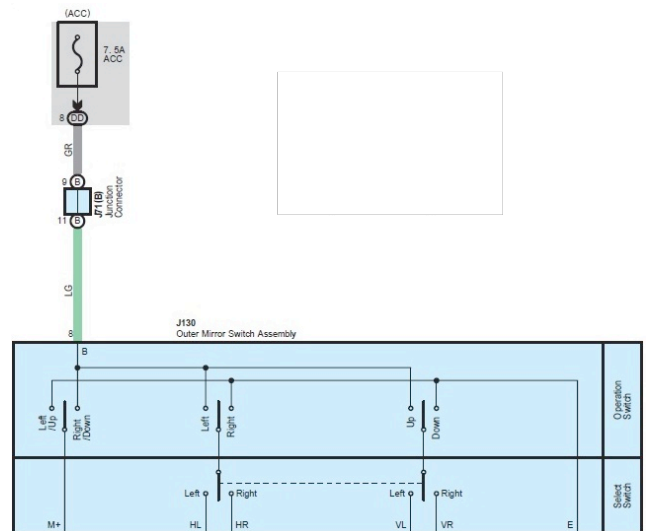

Picture 9A



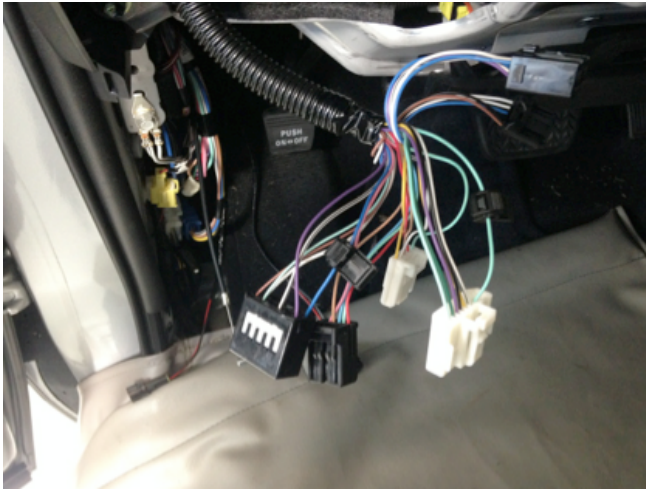

Picture 9B

12. Install a black T-tap to connector J50 pin 1, blue. J50 is located at the back of the cargo light switch. Then connect the blue wire from DRL harness to the t-tap (pictures 10 and 10A).

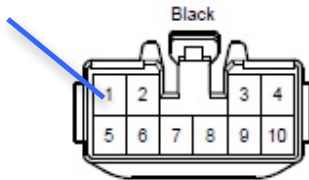

Picture 10: DRL blue wire to connector J50, pin1 (blue wire)

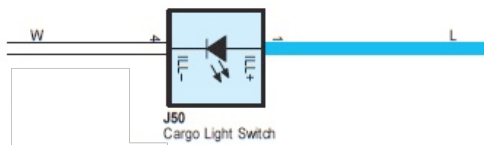

Picture 10A

13. Secure ground (black) wire to bolt by the kick panel (picture 11).



Picture 11

14. Secure relay, fuse and any excess wire from t-taps to factory wire harness, next to driver box (picture 12).



Picture 12

15. Use an empty switch knock out on left panel, (left to the cargo light switch) and mount switch into switch knock out (picture 13).



Picture 13

- 16. Plug DRL harness into switch.
- 17. Reinstall dash panels and connectors.

**ENGINE COMPARTMENT**

- 18. From underneath the hood remove two plastic fasteners from the factory grille located inside of the headlamps with a nylon fastener tool (picture 14).



Picture 14

- 19. Remove four 10mm bolts from the plastic radiator cover then pull the radiator cover upward to remove (picture 15).

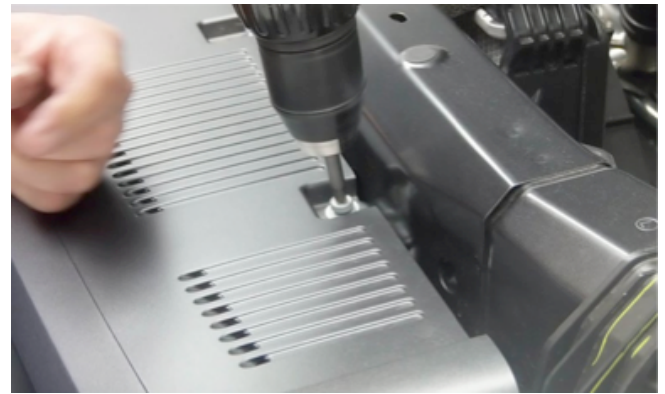

Picture 15

- 20. Pull the top of the grille slightly forward a couple of inches, reach down behind the grille and press on two plastic latches located on the bottom and ends of the factory grille (picture 16) while pulling the bottom of the grille forward, remove the grille from the vehicle (Picture 16A).



Picture 16



Picture 16A



- 21. Using a pry tool, remove the LH and RH plastic bezel below the headlamp (pictures 17 & 17A).



Picture 17



Picture 17A

- 22. Using wire ties, secure the DRL's wire harness along the driver side of vehicle (pictures 18, 18A and 18B)

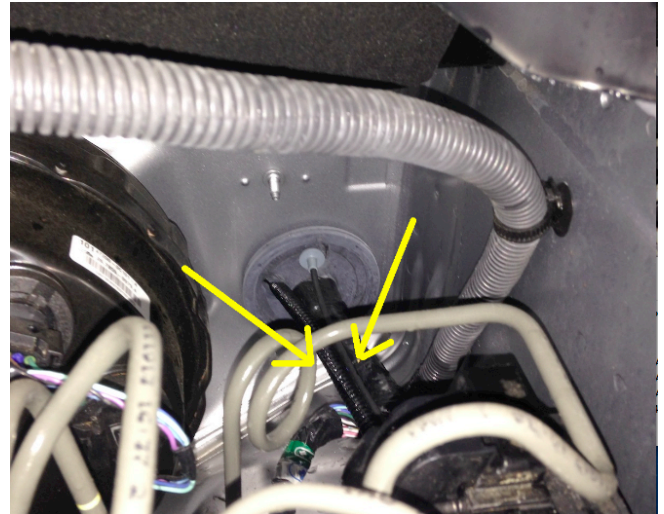

Picture 18

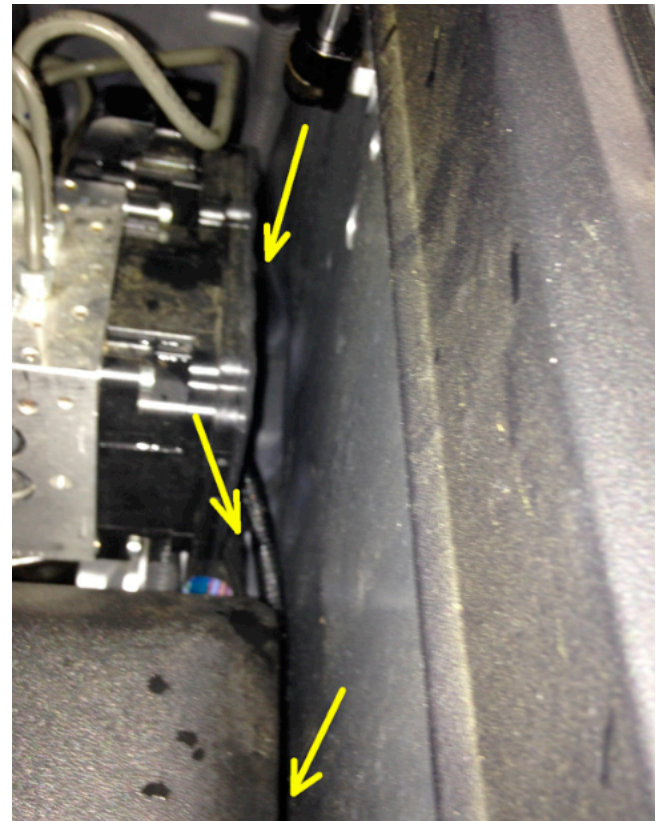

Picture 18A



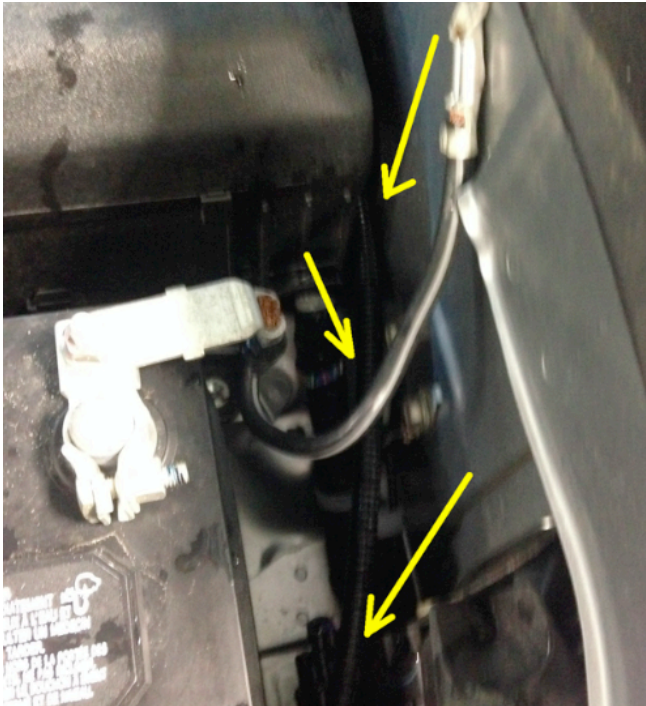

Picture 18B

23. Unplug the driver side factory fog light by accessing behind the factory fog light from underneath the head lamp to unplug fog lamp (picture 19 and 20)



Picture 19

NOTE: For steps 24-27. Fog Light screw can be removed without removing bezel. (Picture 23).

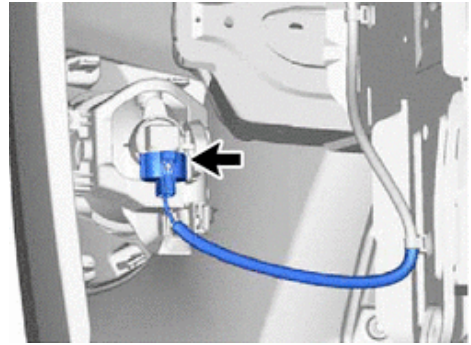

Picture 20

24. For steel bumper models: from the front of the bumper, using a pry tool, remove the bezel from the bumper. There are two claws that secure the bezel to the bumper.

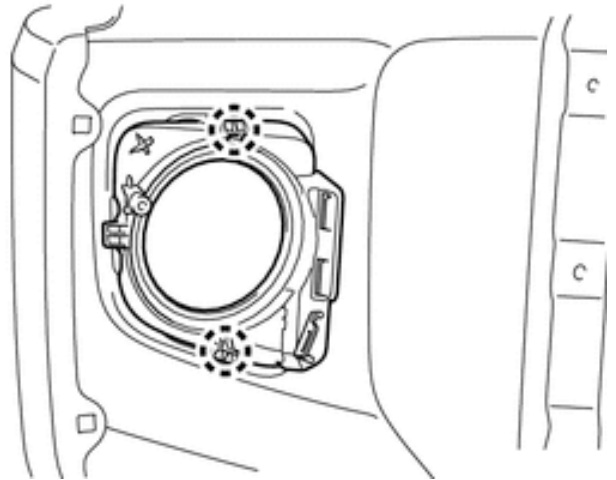

Picture 21



Picture 21A

25. For Resin bumper models: First remove the clip that secures the bezel to the bumper. Then, from the front of the bumper, using a pry tool, remove the bezel from the bumper. There are two claws that secure the bezel to the bumper (picture 22).

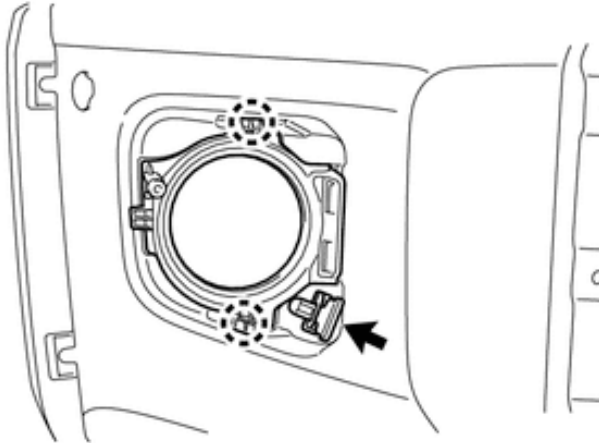

Picture 22: Showing clip on resin bumpers.

26. Remove the factory fog light from bezel: remove Philip screw (do not discard screw, as it will be used to mount 2in1 light). (picture 23).

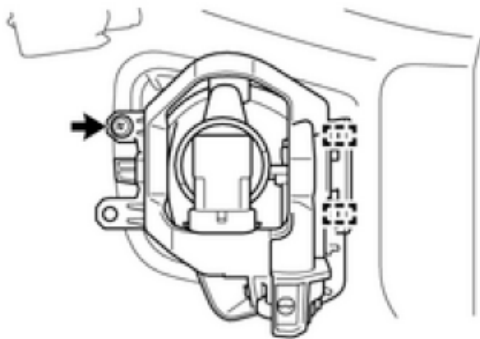

Picture 23

27. Repeat steps 23~26 on passenger side.
28. Mount the LH and RH 2 in 1 Lights into bezels.
29. Run the 2 in1 wire harness to the right side above the bumper, and secure with wire ties as shown (picture 24).

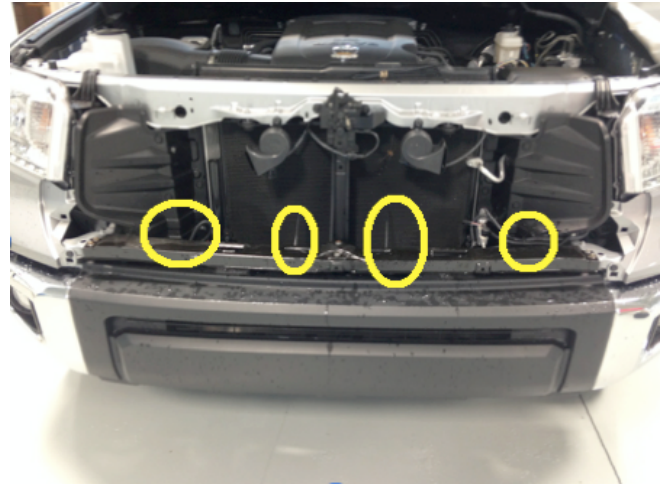

Picture 24

30. Secure excess wires at both sides with wires ties, leaving enough lead to connect the DRL to the harness (picture 25).



Picture 25

31. At the driver side, take the 2 in 1 light and plug the factory fog light connector into 2 in1 fog light terminal and then connect the DRL harness to the 2 in 1 light DRL terminal (picture 26). Then reinstall the 2 in 1 light and bezel back into bumper.



Picture 26

32. Repeat process for passenger side.
33. Secure excess wire from DRL harness with wire ties.
34. Reinstall all panels and radiator grill.
35. Reinstall negative battery cable and torque to 48 in-lbs
36. Adjust fog light aiming by following the procedure below.



### Fog Light Aiming

Traditional fog lights are usually mounted in the front bumper about 10-24 inches from the ground. There are two important issues to address when installing fog lights: the first is to minimize the amount of return glare into the drivers eyes, and the other is to minimize the glare into oncoming eyes. Both of these issues must be accomplished while putting as much light as possible on the road.

These fog weather light aiming instructions are suggestions taken from common practice and the S.A.E. standard J583. Some modifications to these instructions may be necessary to minimize glare.

Visual aim is made with the top of the beam 4 inches below the lamp center at 25 feet with the lamp facing straight forward (see picture 25)

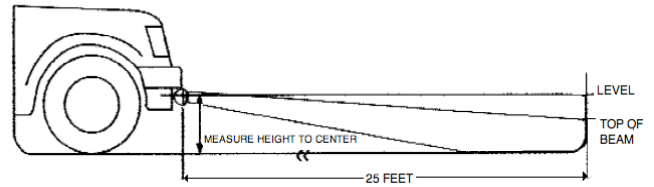

Picture 25

**NOTE:** Use only hand tools to adjust the fog light aiming screw. DO NOT use automatic tools, as they will damage the fog light



**Checklist** – these points MUST be checked to ensure quality installation

**Check System for Operation**

1. DRL will work at full power when ignition switch is ON. DRL will dim out to DOT specifications when lights are ON.
2. If DRL switch position is off, DRL will not work at any time.

**Check**

Accessory Functions Checks

- 
- DRL function.....
  - Fog Lights function.....
  - All Panels snapped into place.....
  - Fog Lights.....
  - Battery Terminal.....
  - Operation Guide.....

Vehicle Function checks

Check functions all switch functions

---

**Look For:**

- 
- ....
  - ....
  - Loose panels and switches
  - Visually confirm lights are straightforward
  - Re-torque battery terminals to 48 in-lb
  - Place DRL operation guide inside glove box.

# Block Diagram

## LED DRL + LED Fog Light 2in1

### Tundra 2016

00016-48011 Ver. 9.11.2015

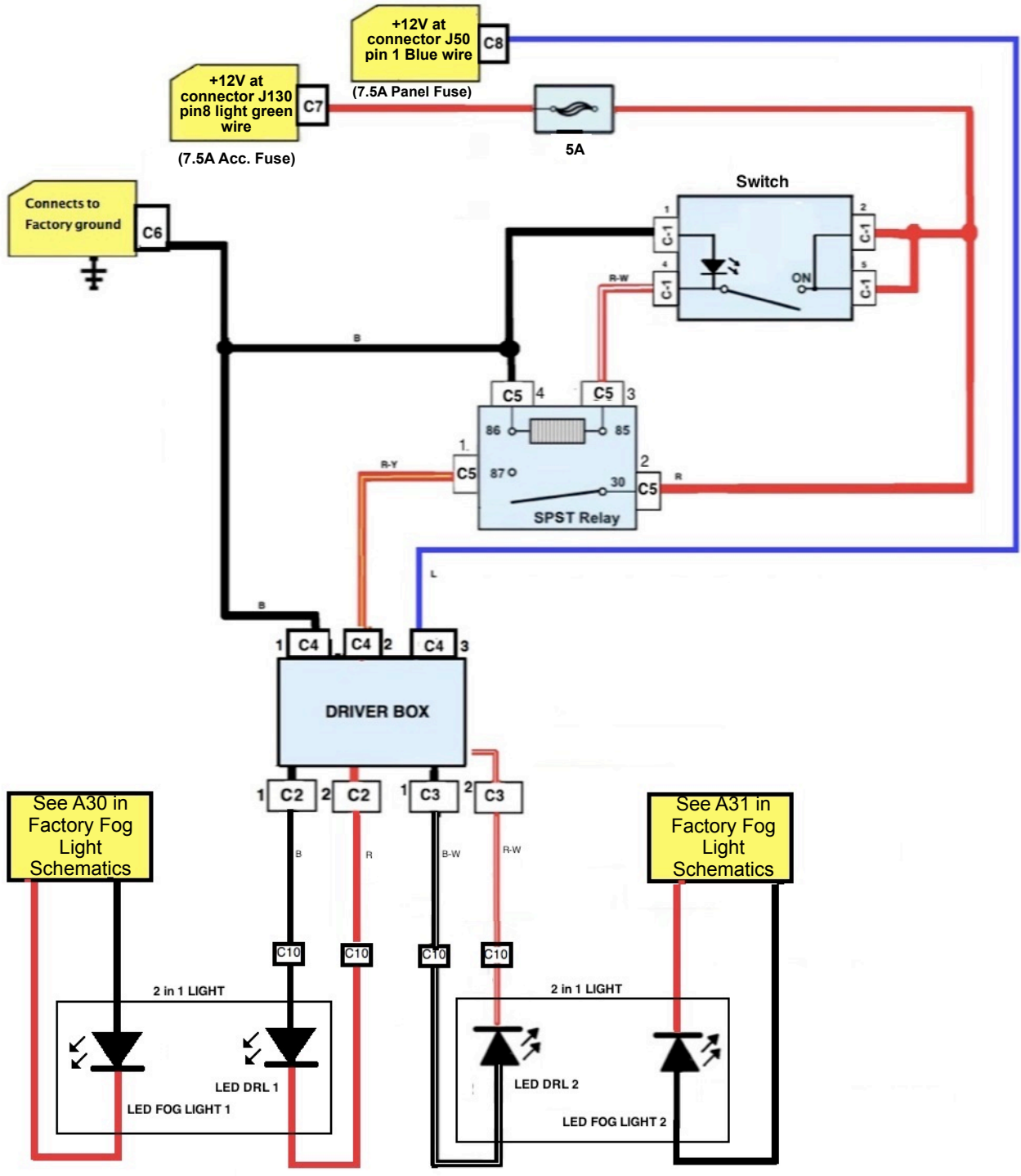

# Pinout test

## Connector C-1

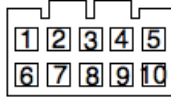

Pin	Wire Color	Test Reference	Proper Operation
1	Black	Pin 1 to Ground	Approximately 0 VDC
2	Red	Pin 2 to Ground	Approximately 0 VDC ignition switch is OFF +12 VDC when ignition switch is ON
4	Red-White	Pin 4 to Ground	Approximately 0 VDC ignition switch is OFF Approximately 0 VDC ignition switch is ON, DRL switch is OFF +12 VDC when ignition switch is ON and DRL switch is ON
5	Red	Pin 5 to Ground	Approximately 0 VDC ignition switch is OFF +12 VDC when ignition switch is ON

## Connector C-2, C-3

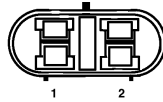

Pin	Wire Color	Test Reference	Proper Operation
1	Red or Red-White	Pin 1 to Ground	Aproximately 0 VDC when ignition switch is OFF Aproximately 0 VDC when ignition switch is ON, DRL switch is OFF Aproximately +18 to +24 VDC when ignition switch is ON, DRL switch is ON
2	Black or Black-White	Pin 2 to Ground	Aproximately 0 VDC

## Connector C-4

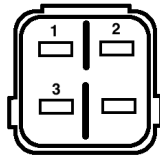

Pin	Wire Color	Test Reference	Proper Operation
1	Black	Pin 1 to Ground	Aproximately 0 VDC
2	Red-Yellow	Pin 2 to Ground	Approximately 0 VDC ignition switch is OFF Approximately 0 VDC ignition switch is ON, DRL switch is OFF +12 VDC when ignition switch is ON and DRL switch is ON
3	Blue	Pin 3 to Ground	Aproximately 0 VDC dash panel lights are OFF +12 VDC when dash panel lights are ON



### Connector C-5

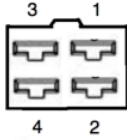

FEMALE TERMINAL VIEW

Pin	Wire Color	Test Reference	Proper Operation
1	Red-Yellow	Pin 1 to Ground	Approximately 0 VDC ignition switch is OFF Approximately 0 VDC ignition switch is ON, DRL switch is OFF +12 VDC when ignition switch is ON and DRL switch is ON
2	Red	Pin 2 to Ground	Approximately 0 VDC ignition switch is OFF +12 VDC when ignition switch is ON
3	Red-White	Pin 3 to Ground	Approximately 0 VDC ignition switch is OFF Approximately 0 VDC ignition switch is ON, DRL switch is OFF +12 VDC when ignition switch is ON and DRL switch is ON
4	Black	Pin 3 to Ground	Aproximately 0 VDC

### Connector C-6



Pin	Wire Color	Test Reference	Proper Operation
1	Black	Pin 1 to Ground	Aproximately 0 VDC

### Connector C-7



Pin	Wire Color	Test Reference	Proper Operation
1	Red	Pin 1 to Ground	Aproximately 0 VDC when ignition switch is OFF +12 VDC when ignition switch is ON

### Connector C-8



Pin	Wire Color	Test Reference	Proper Operation
1	Blue	Pin 1 to Ground	Approximately 0 VDC dash panel lights are OFF +12 VDC when dash panel lights are ON

### Connector C-10

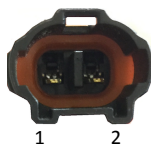

Pin	Wire Color	Test Reference	Proper Operation
1	Black	Pin 1 to Ground	Aproximately 0 VDC
2	Red	Pin 2 to Ground	Approximately 0 VDC when ignition switch is OFF Approximately 0 VDC when ignition switch is ON, DRL switch is OFF Approximately +18 to +24 VDC when ignition switch is ON, DRL switch is ON