

TOYOTA

Highlander

2016

LED Fog Light & DRL 2in1

Part Number: 00016-00081

Accessory Code: LD4010



**Conflicts**

- Vehicles w/o factory Fog Lights
-----------------------------------

**Kit Contents**

Item #	Quantity Req'd.	Description
1	2	Fog + DRL Housings
2	1	DRL Driver Box
3	1	DRL Harness Bag
4	1	DRL User's Card
5	1	DRL Switch

**Hardware Bag Contents**

Item #	Quantity Req'd.	Description
1	1	Hood Wire harness
2	1	Cabin Wire harness
3	1	Relay
4	25	Wire ties
5	1	14" wire tie
6	2	Black T-Taps
7	1	10 mm nut

**Additional Items Required For Installation**

Item #	Quantity Req'd.	Description

**Recommended Tools**

<b>Safety Tools</b>	
Safety Glasses	
Electrical Tape	
<b>Installation Tools</b>	
10mm Wrench	
Phillips Screw Driver	Stubby # 2
Pliers	
Torque Wrench	48 in-lb
Side Cutters	
<b>Special Chemicals</b>	
3M Silicon Sealant	

**Accessory Service Parts**

Service Part Part Number	DRL + Fog Housing LH	DRL + Fog Housing RH	DRL Switch	DRL Wire Harness	DRL Driver Box	DRL Relay
00016-00081-01	X					
00016-00081-02		X				
00016-32270-05			X			
00016-32270-03				X		
00016-32270-06					X	
00016-32260-04						X

**General Applicability**

Models with factory fog lights
--------------------------------

**Recommended Sequence of Application**

Item #	Accessory
1	
2	
3	

Mandatory Legend

**STOP:** Damage to the vehicle may occur. Do not proceed until process has been complied with.

**OPERATOR SAFETY:** Use caution to avoid risk of injury.

**CAUTION:** A process that must be carefully observed in order to reduce the risk of damage to the accessory/vehicle and to ensure a quality installation.

**TOOLS & EQUIPMENT:** Used in Figures calls out the specific tools and equipment recommended for this process.

**REVISION MARK:** This mark highlights a change in installation with respect to previous issue.

**SAFETY TORQUE:** This mark indicates that torque is related to safety.

**SPECIAL NOTE:**  
 After TMS and Safety mandated preparatory steps have been taken, the installation sequence is the suggested method for completing the accessory installation. In some instances the suggested sequence is written for one associate to install and in others the sequence is given as part of a team accessory installation. Unless otherwise stated in the document, the associates may perform the installation steps in any order to make the installation as efficient as possible while maintaining consistent quality. Also some items listed to be removed may not need to be removed if caution is taken to not damage vehicle.

Care must be taken when installing this accessory to ensure damage does not occur to the vehicle. The installation of this accessory should follow approved guidelines to ensure quality installation. These guidelines can be found in the Accessory Installation Practices document.

This document covers such items as:

- Vehicle Protection (use of covers and blankets, cleaning chemicals, etc)
- Safety (eye protection)
- Vehicle Disassembly / Reassembly (panel removal, part storage, etc)

**Preparation**



Remove negative battery cable

**Installation**

1. From front of vehicle, lay the DRL's wire harness on the engine compartment, right side of the battery.
2. Drop the wire harness down towards the driver's side fog light area.
3. From under the car, remove the lower splash shield and splash guards: Remove the 10mm screws (pictures 1 and 2)

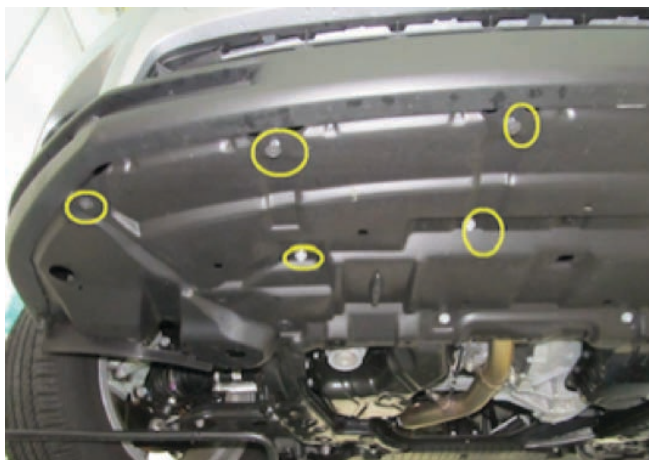

Picture 1



Picture 2

4. Retrieve the DRL's wire harness and run the passenger end towards the right side of vehicle.
5. Secure wire harness behind lower bumper sheet metal (picture 3~3C).



Picture 3



Picture 3A

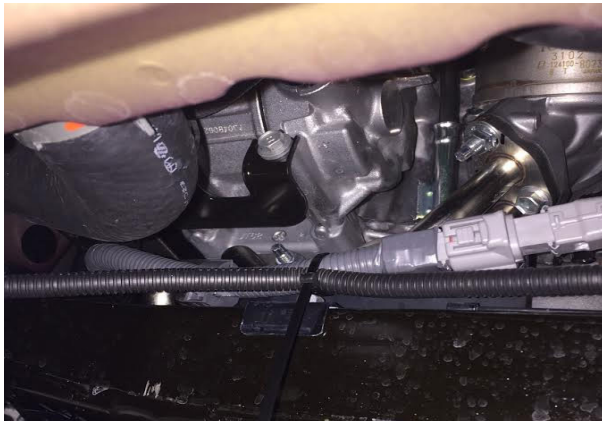

Picture 3B



Picture 3C

6. Unplug passenger side fog lamp (pic. 4)

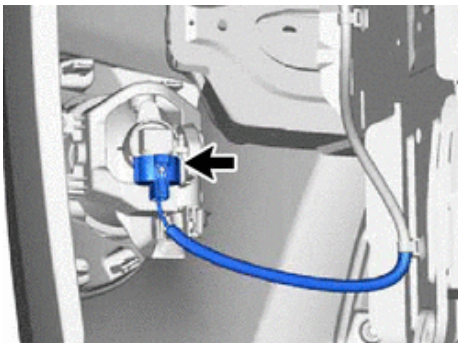

Picture 4

7. Remove passenger side fog lamp, by removing 1 factory screw. Reach fog light housing between bumper and lowered splash-guard and remove. Note: screws will be used on installation, do not discard them (pic. 5~5A).

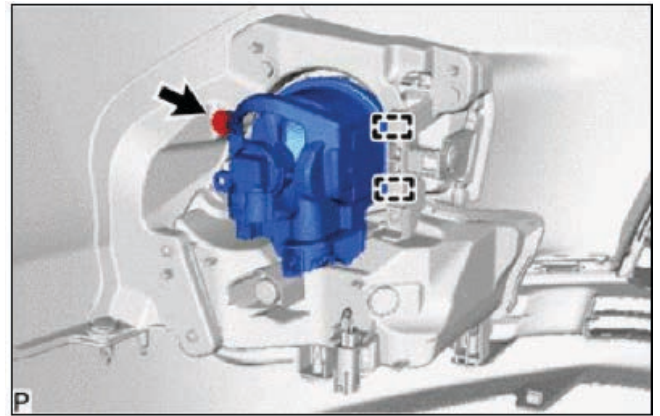

Picture 5



Picture 5A

**Note:** If the fog light connector is pre-installed in the kit, proceed to step 11

8. The factory fog light harness polarity is shown in picture 6. Pin 1 is negative. Pin2 is positive

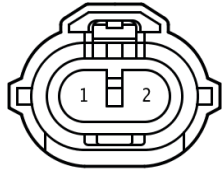

Picture 6: Factory Fog Light harness.  
Pin 1: Negative  
Pin 2: Positive



Picture 6A

9. Push the wires from LED fog light housing into the supplied connector, to match the polarity of the factory wire harness (pic. 7).



Picture 22: 2in1 Fog Light wire terminal.



Picture 7A: Showing Fog light terminal connected.

10. Before connecting the LED Fog light, make sure that wires are aligned as follows
  - LED Fog light red (+) with factory blue (+)
  - LED Fog Light black (-) with factory white-black (-)

11. Install the passenger side 2in1 light housing into the bumper's plastic sleeve and secure other side with factory screw. Plug the factory fog light connector into LED fog light connector. Then plug the DRL wire harness connector to the 2in1 DRL connector (picture 8 and 8A).



Picture 8



Picture 8A

12. At the driver side, turn wheel to the left and remove the front/lower part of the fender liner (picture 9)

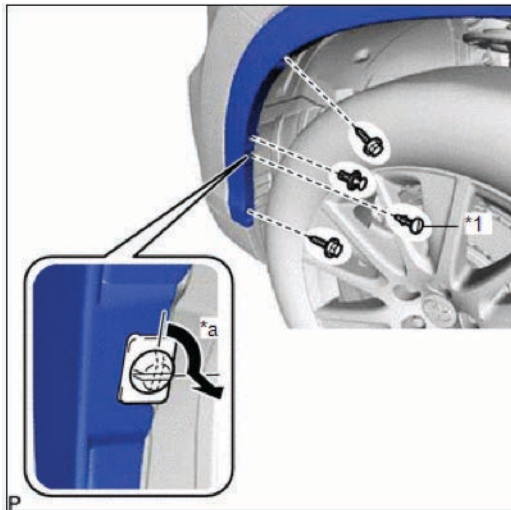

*1	Pin Hold Clip
*a	90°

Picture 9

13. From behind of fender liner, disconnect and remove the driver's side factory fog light by removing 1 factory screw. Lamp can be removed through the opening of the lowered fender liner.
14. Then install and connect 2in1 light housing.
15. Secure excess wire from DRL harness with wire ties at the passenger side

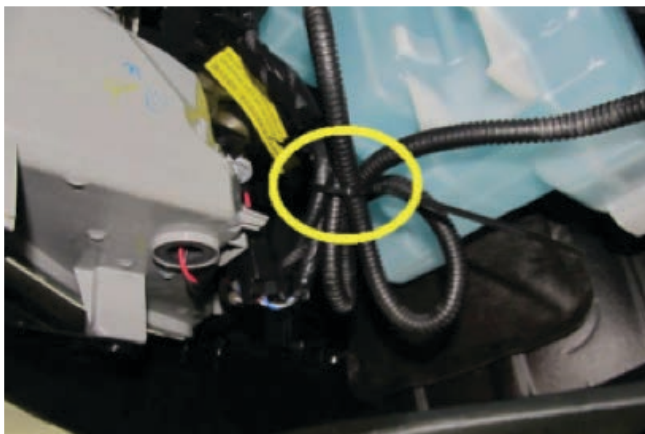

Picture 10

16. Reinstall lower splash shield.
17. Remove top and rear part of the driver's side fender liner (picture 11~11A)



Picture 11



Picture 11A

18. Run wire harness from driver's side fog light area towards the opening behind the head-lamp. Reach wire harness from the wheel well opening (picture 12)



Picture 12

19. From behind wheel liner, retrieve DRL harness and route towards hood release cable grommet (following the hood release cable). Secure with wire ties (pic. 14~14B).  
Note: Use the factory white clips to secure the wire harness.



Picture 14



Picture 14A



Picture 14B

20. Locate the hood-release cable grommet. Cut the grommet and push the red, black, black-white and red-white wires through firewall. Note: Extra caution should be taken not to damage the connector's pin. Secure wire with a wire tie and then seal with 3M Silicone sealant (picture 15~15I)

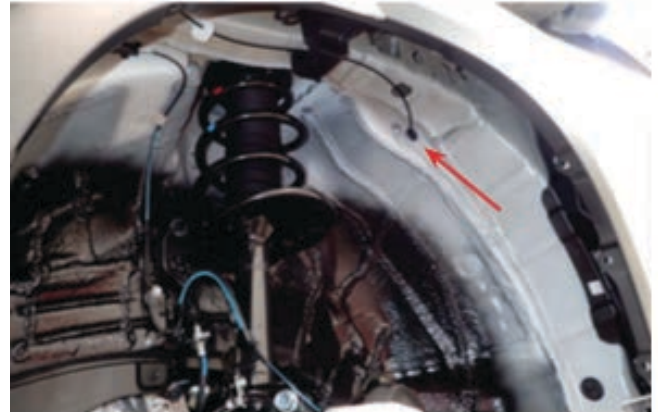

Picture 15

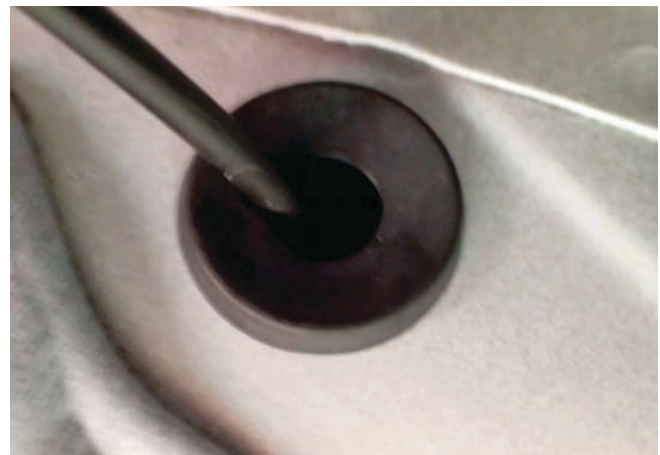

Picture 15A: Showing the grommet



Picture 15B: Showing hood cable grommet back-side (removed)



Picture 15C: Showing where to cut the grommet



Picture 15D: Use Side cuts

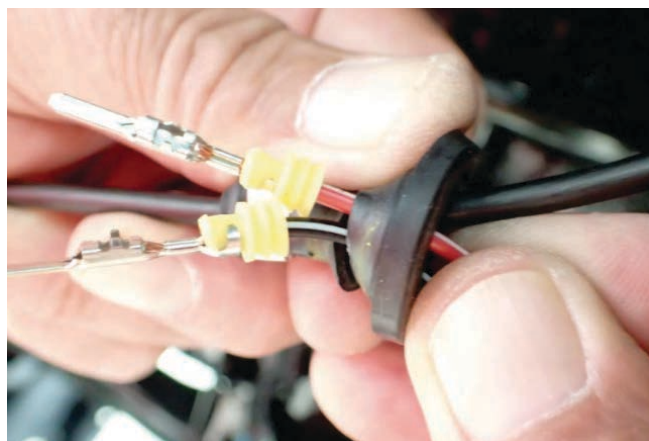

Picture 15E: Running the wires through the grommet



Picture 15F: do not push tape or plastic through grommet.



Picture 15G: Loop harness and zip tie to hood cable

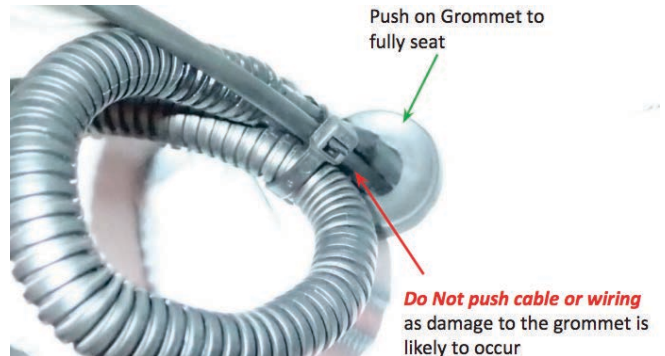

Picture 15H

**NOTE:** Make sure the grommet is properly installed: Lift edges to verify engagement.

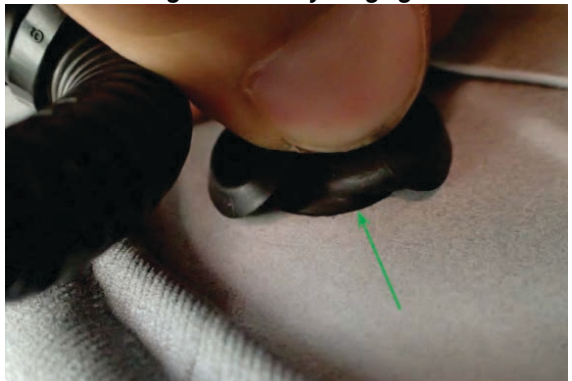

Picture 15I

- 21. Secure DRL harness behind wheel well area with wire ties.

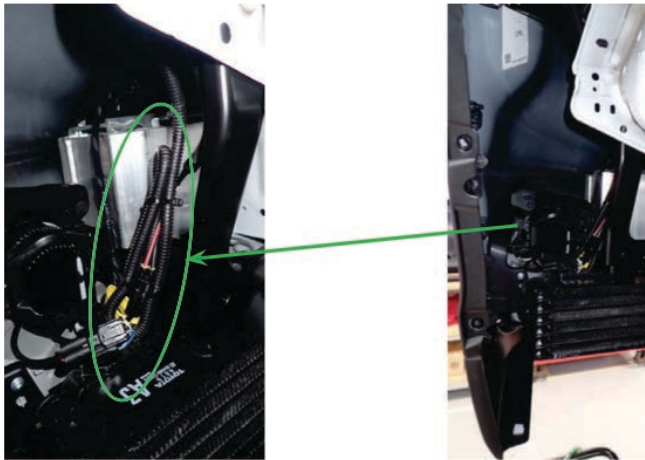

Picture 16

- 22. Reinstall fender liner.

**Vehicle Disassembly**

- 23. Remove driver side door scuff plate: Disengage with panel tool and remove (pic.17)

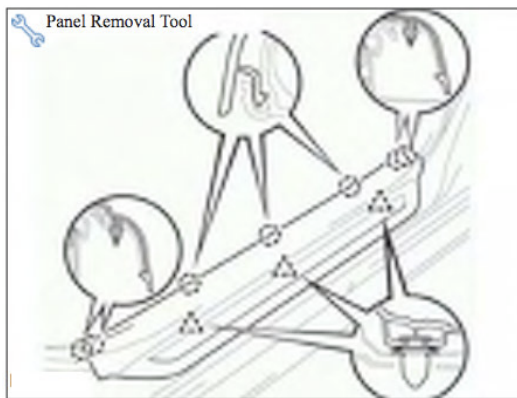

Picture 17

- 24. Then, remove the driver side cowl side trim. Unscrew the cowl side trim clip. Disengage two (2) clips and remove the cowl side trim (picture 17A)

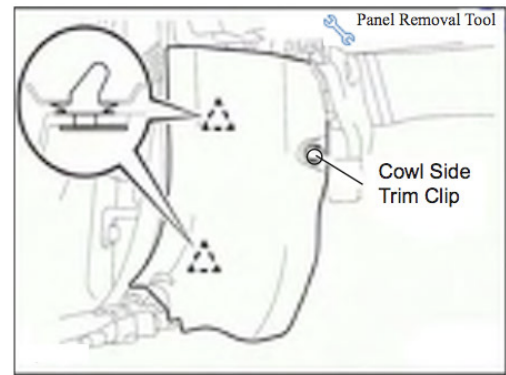

Picture 17A

- 25. Remove the driver's side panel. Disengage with panel tool and remove (picture 18)



Picture 18

- 26. Remove the driver's side under cover sub assembly by removing the 2 screws at the bottom and disengaging clips of the panel (picture 19 ~ 19A)

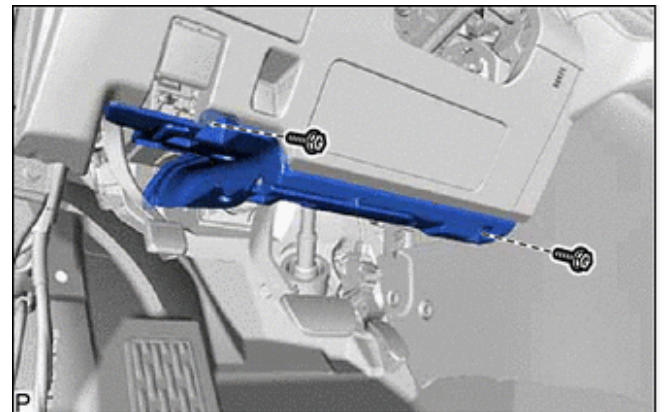

Picture 19



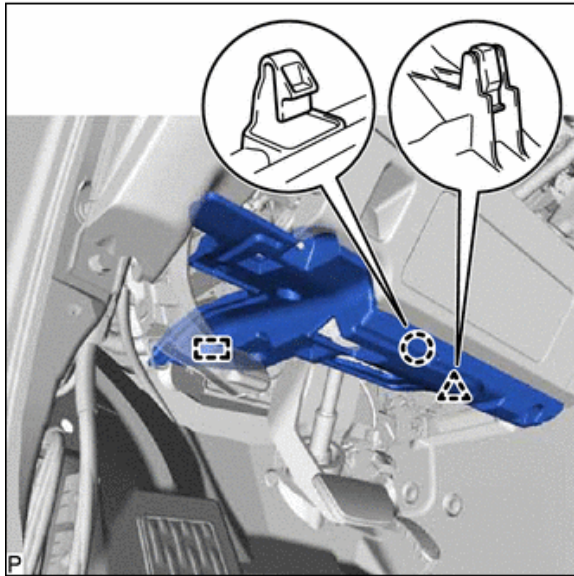

Picture 19A

27. Remove driver side lower dash panel by removing 1 screw, clips and remove hood cable. (picture 20~20A)

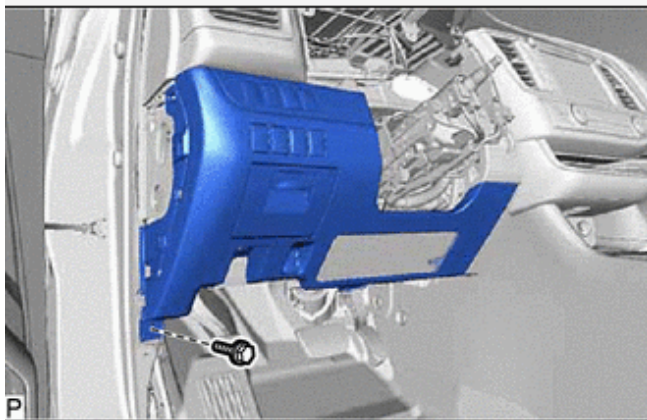

Picture 20



Picture 20A

28. Locate the wires that were pushed through the grommet in step 19. Route wire harness towards the left side of steering wheel. Use wire ties as needed (picture 21)

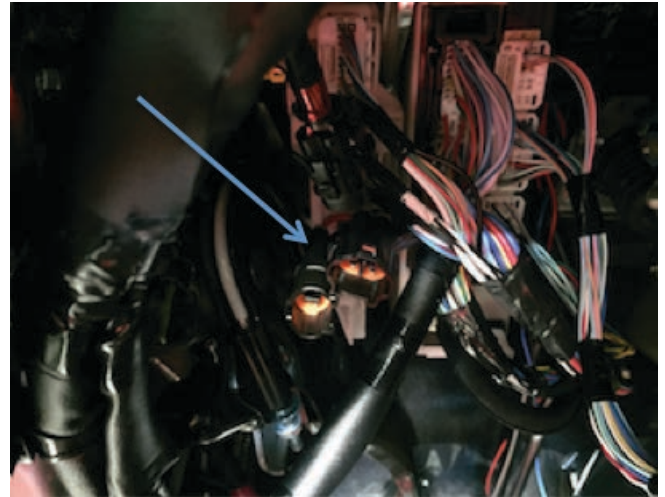

Picture 21

29. Push the pins of the DRL wire harness into the connector supplied in kit. The connector has a "+" and "-" marks. So connect the red wire into the "+" side and black wire into the "-" side. You may use the driver box as a guide: wire colors must be aligned with the wire colors of the driver box: black with black and red with red, etc (picture 21A)



Picture 21A

30. Connect the driver box to the wire harness (make sure wire colors are aligned).
31. Using a 14" wire tie, secure the driver box to factory harness with the single connector on top

secure top of driver box with wire tie and tighten behind harness(pictures 22~22A).

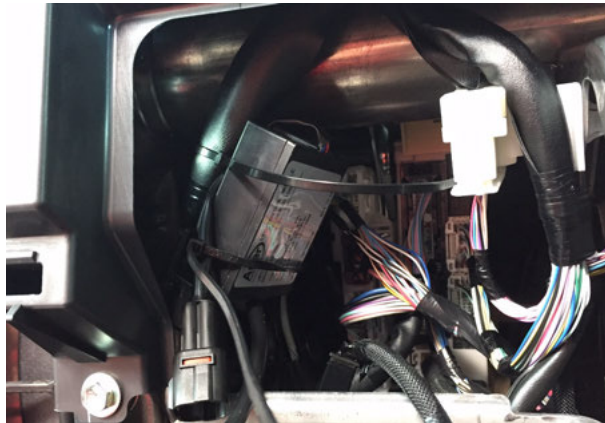

Picture 22



Picture 22A

32. Using the supplied 10 mm nut, secure the black wire with a ring terminal from DRL harness to the empty bolt next to the 10mm nut on top of junction block (picture 23)

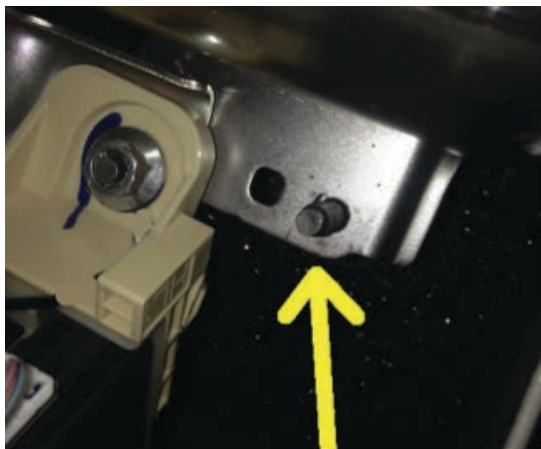

Picture 23

33. Install a black T-Tap to connector 4F pin 19, black wire. Then connect the red wire from DRL harness to T-tap. Connector 4F is located at the main junction block. (pictures 24~24C). Connector 4F pin 19 is a 12V ignition source.

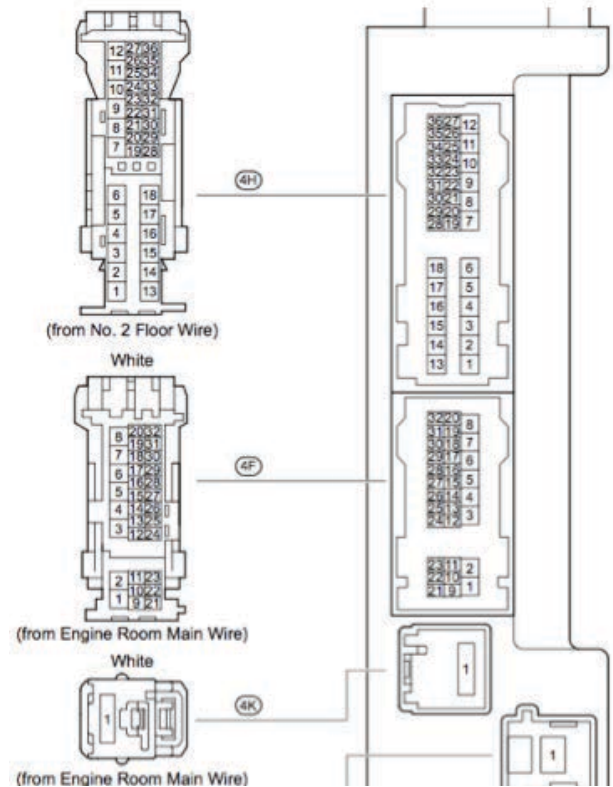

Picture 24



Picture 24A

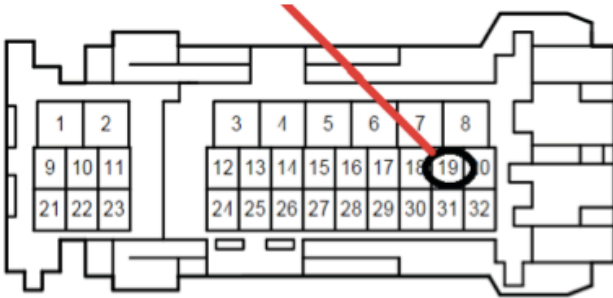

Picture 24B:

DRL's red wire to connector 4F, Pin 19, black wire (10A Ignition Fuse No3)

Connector 4F has 3 rows:  
1<sup>st</sup> with 8 pins, middle row: 12 pins and 3<sup>rd</sup> row 12 pins

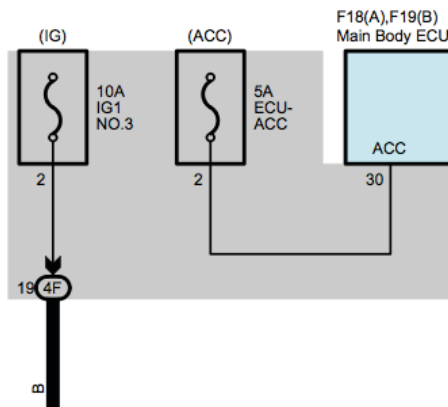

Picture 24C

34. Install a black T-Tap to connector IF1, pin 6, red wire. Then connect the blue wire from DRL harness to t-tap. Connector IF1 is located at the kick panel. Connector IF1 is the power window control illumination circuit. IF1 is a gray connector (pictures 25~25B).



Picture 25

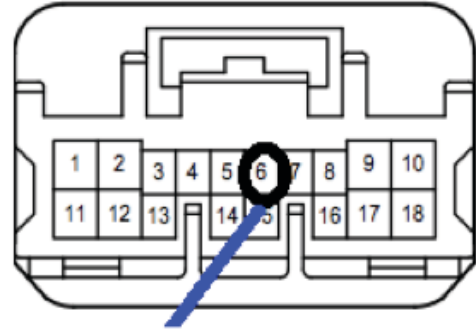

Picture 25A

DRL's blue wire to connector IF1, pin 6, red wire (5A panel fuse)

Connector IF1 has 2 rows:  
1<sup>st</sup> with 10 pins and 2<sup>nd</sup> with 8 pins.  
It is a gray connector

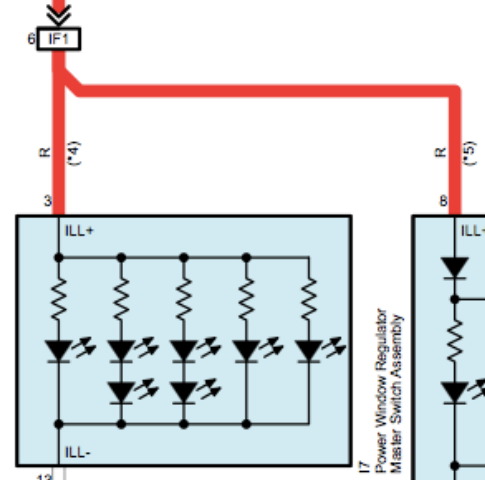

Picture 25B

35. Secure any excess wire from t-taps, fuse and relay to main wire harness (picture 26). Make sure to leave enough lead on the switch's green connector.



Picture 26

36. Push out the switch knockout located at the left of the steering wheel. Route DRL switch connector through switch knockout. Connect the switch wire harness to switch, then mount switch into dash panel (pic 27).



Picture 27

37. Reinstall panels and connectors.
38. Reconnect negative battery terminal. Torque terminal to 48 in-lbs.



38. Reconnect negative battery terminal. Torque terminal to 48 in-lbs.



Right: showing LED Fog Light "ON"  
Left: Showing DRL "ON"

### Fog Light Aiming

Traditional fog lights are usually mounted in the front bumper about 10-24 inches from the ground. There are two important issues to address when installing fog lights: the first is to minimize the

amount of return glare into the drivers eyes, and the other is to minimize the glare into oncoming eyes. Both of these issues must be accomplished while putting as much light as possible on the road.

These fog weather light aiming instructions are suggestions taken from common practice and the S.A.E. standard J583. Some modifications to these instructions may be necessary to minimize glare.

Visual aim is made with the top of the beam 4 inches below the lamp center at 25 feet with the lamp facing straight forward (see picture 28)

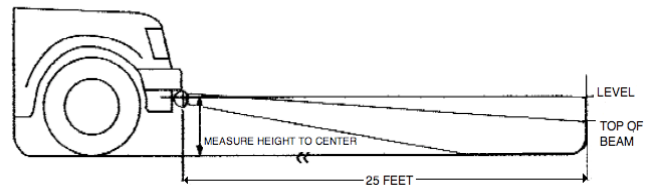

Picture 28

**NOTE:** Use only hand tools to adjust the fog light aiming screw. DO NOT use automatic tools, as they will damage the fog light

**Checklist** – these points MUST be checked to ensure quality installation

**Check System for Operation**

1. DRL will work at full power when ignition switch is ON. DRL will dim out to DOT specifications when lights are ON.
2. If DRL switch position is off, DRL will not work at any time.

**Check**

Accessory Functions Checks

---

- DRL function.....
- Fog Lights function.....
- All Panels snapped into place.....
- Fog Lights.....
- Battery Terminal.....
- Operation Guide.....

Vehicle Function checks

---

- Check functions all switch functions

**Look For:**

---

- ....
- ....
- Loose panels and switches
- Visually confirm lights are straightforward
- Re-torque battery terminals to 48 in-lb
- Place DRL operation guide inside glove box.

# Block Diagram

## LED DRL + LED Fog Light 2in1 Highlander 2016

00016-00081 Ver.02.04.2016

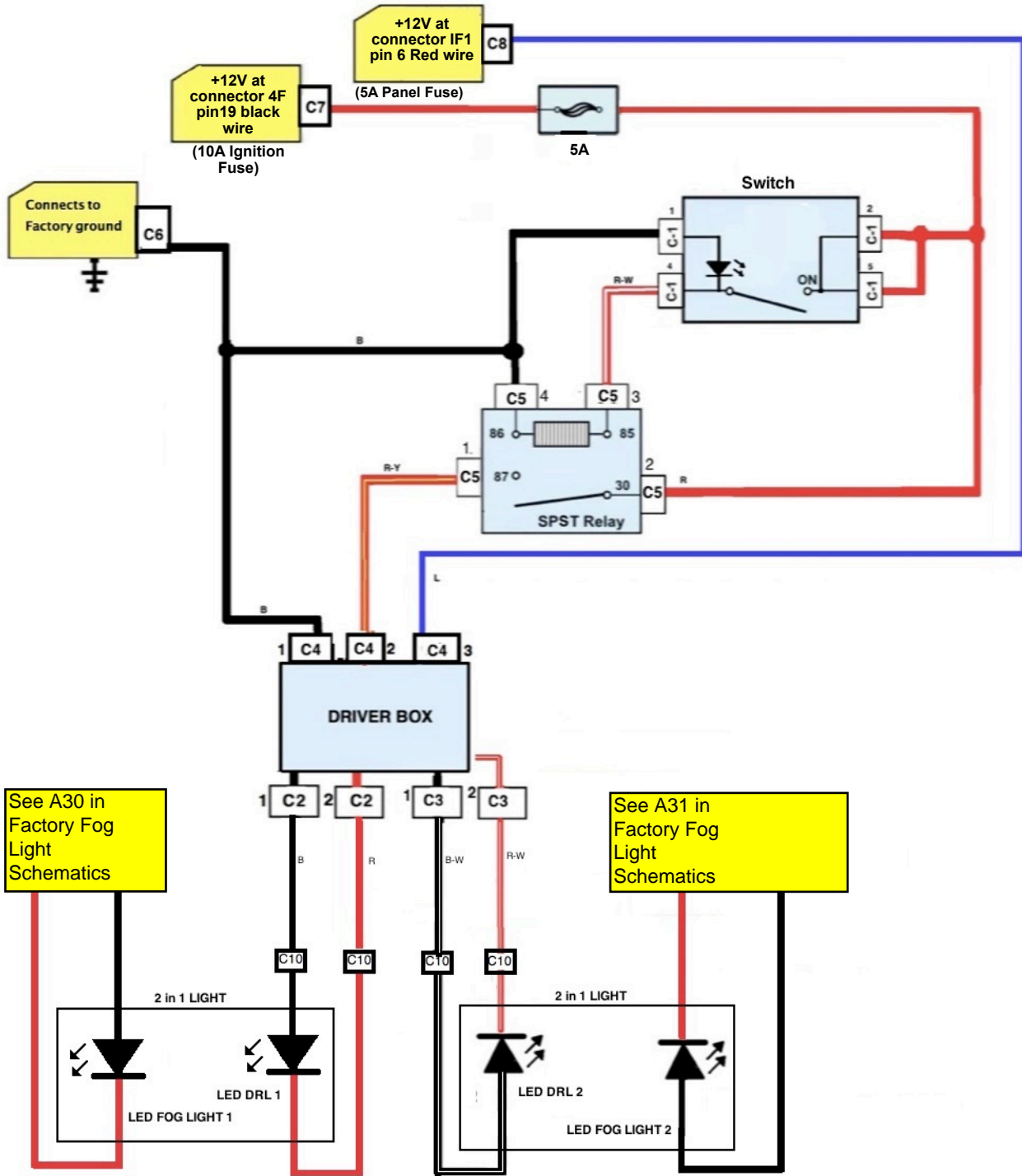

# Pinout test

## Connector C-1

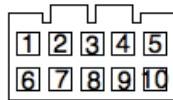

Pin	Wire Color	Test Reference	Proper Operation
1	Black	Pin 1 to Ground	Approximately 0 VDC
2	Red	Pin 2 to Ground	Approximately 0 VDC ignition switch is OFF +12 VDC when ignition switch is ON
4	Red-White	Pin 4 to Ground	Approximately 0 VDC ignition switch is OFF Approximately 0 VDC ignition switch is ON, DRL switch is OFF +12 VDC when ignition switch is ON and DRL switch is ON
5	Red	Pin 5 to Ground	Approximately 0 VDC ignition switch is OFF +12 VDC when ignition switch is ON

## Connector C-2, C-3

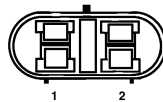

Pin	Wire Color	Test Reference	Proper Operation
1	Red or Red-White	Pin 1 to Ground	Aproximately 0 VDC when ignition switch is OFF Aproximately 0 VDC when ignition switch is ON, DRL switch is OFF Aproximately +18 to +24 VDC when ignition switch is ON, DRL switch is ON
2	Black or Black-White	Pin 2 to Ground	Aproximately 0 VDC

## Connector C-4

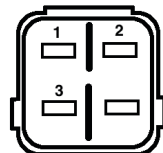

Pin	Wire Color	Test Reference	Proper Operation
1	Black	Pin 1 to Ground	Aproximately 0 VDC
2	Red-Yellow	Pin 2 to Ground	Approximately 0 VDC ignition switch is OFF Approximately 0 VDC ignition switch is ON, DRL switch is OFF +12 VDC when ignition switch is ON and DRL switch is ON
3	Blue	Pin 3 to Ground	Aproximately 0 VDC dash panel lights are OFF +12 VDC when dash panel lights are ON

### Connector C-5

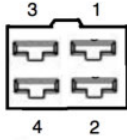

FEMALE TERMINAL VIEW

Pin	Wire Color	Test Reference	Proper Operation
1	Red-Yellow	Pin 1 to Ground	Approximately 0 VDC ignition switch is OFF Approximately 0 VDC ignition switch is ON, DRL switch is OFF +12 VDC when ignition switch is ON and DRL switch is ON
2	Red	Pin 2 to Ground	Approximately 0 VDC ignition switch is OFF +12 VDC when ignition switch is ON
3	Red-White	Pin 3 to Ground	Approximately 0 VDC ignition switch is OFF Approximately 0 VDC ignition switch is ON, DRL switch is OFF +12 VDC when ignition switch is ON and DRL switch is ON
4	Black	Pin 3 to Ground	Aproximately 0 VDC

### Connector C-6



Pin	Wire Color	Test Reference	Proper Operation
1	Black	Pin 1 to Ground	Aproximately 0 VDC

### Connector C-7



Pin	Wire Color	Test Reference	Proper Operation
1	Red	Pin 1 to Ground	Aproximately 0 VDC when ignition switch is OFF +12 VDC when ignition switch is ON

### Connector C-8

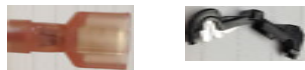

Pin	Wire Color	Test Reference	Proper Operation
1	Blue	Pin 1 to Ground	Approximately 0 VDC dash panel lights are OFF +12 VDC when dash panel lights are ON

### Connector C-10



Pin	Wire Color	Test Reference	Proper Operation
1	Black	Pin 1 to Ground	Aproximately 0 VDC
2	Red	Pin 2 to Ground	Approximately 0 VDC when ignition switch is OFF Approximately 0 VDC when ignition switch is ON, DRL switch is OFF Approximately +18 to +24 VDC when ignition switch is ON, DRL switch is ON