

TOYOTA

4Runner

2016

LED Fog Light & DRL 2in1

Part Number: 00016-00081

Accessory Code: LD4000



Conflicts

-Vehicles W/O factory Fog Lights

Kit Contents

Item #	Quantity Req'd.	Description
1	2	Fog + DRL Housings
2	1	Driver Box
3	1	Harness Bag
4	1	User's Card
5	1	Switch

Hardware Bag Contents

Item #	Quantity Req'd.	Description
1	1	Hood Wire harness
2	1	Cabin Wire harness
3	1	Relay
4	25	Wire ties
5	1	14" wire tie
6	2	Black T-Taps

Additional Items Required For Installation

Item #	Quantity Req'd.	Description

Recommended Tools

Safety Tools	
Safety Glasses	
Electrical Tape	
Installation Tools	
10mm Wrench	Protective tape
Stubby Phillips Screw Driver	
Pliers	
Torque Wrench	48 & 53 in-lb
Side Cutters	
Nylon Tool	
Special Chemicals	
3M Silicon Sealant	

Accessory Service Parts

Service Part	DRL + Fog Housing LH	DRL + Fog Housing RH	DRL Switch	DRL Wire Harness	DRL Driver Box	DRL Relay
00016-00081-01	X					
00016-00081-02		X				
00016-32270-05			X			
00016-32270-03				X		
00016-32270-06					X	
00016-32260-04						X

General Applicability

2016 Models

Recommended Sequence of Application

Item #	Accessory
1	LED Foglight & DRL 2 in 1
2	TMS Fender Well Modification
3	

Mandatory

Legend

STOP: Damage to the vehicle may occur. Do not proceed until process has been complied with.

OPERATOR SAFETY: Use caution to avoid risk of injury.

CAUTION: A process that must be carefully observed in order to reduce the risk of damage to the accessory/vehicle and to ensure a quality installation.

TOOLS & EQUIPMENT: Used in Figures calls out the specific tools and equipment recommended for this process.

REVISION MARK: This mark highlights a change in installation with respect to previous issue.

SAFETY TORQUE: This mark indicates that torque is related to safety.

SPECIAL NOTE:
 After TMS and Safety mandated preparatory steps have been taken, the installation sequence is the suggested method for completing the accessory installation. In some instances the suggested sequence is written for one associate to install and in others the sequence is given as part of a team accessory installation. Unless otherwise stated in the document, the associates may perform the installation steps in any order to make the installation as efficient as possible while maintaining consistent quality. Also some items listed to be removed may not need to be removed if caution is taken to not damage vehicle.

Care must be taken when installing this accessory to ensure damage does not occur to the vehicle. The installation of this accessory should follow approved guidelines to ensure quality installation. These guidelines can be found in the Accessory Installation Practices document.

This document covers such items as:

- Vehicle Protection (use of covers and blankets, cleaning chemicals, etc)
- Safety (eye protection)
- Vehicle Disassembly / Reassembly (panel removal, part storage, etc)

Preparation



Remove the NEGATIVE (-) battery terminal before starting any disassembly.



Do not touch the positive terminal.



Wait at least 90 seconds after disconnecting the cable from the negative (-) battery terminal to disable the SRS system.

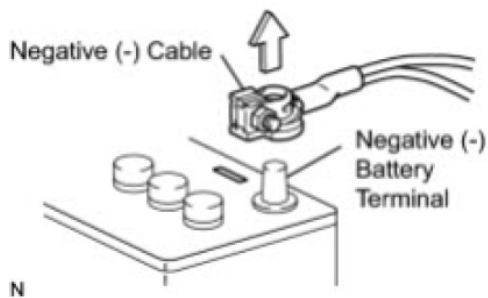

Installation

1. From front of vehicle, lay the DRL's wire harness on the engine compartment, left side from the battery towards the firewall of the car.
2. Locate the large vehicle harness grommet on the left side. If accessible, cut the auxiliary wiring access nipple off the grommet or cut 1/4" slit in grommet and push the red, black, black-white and red-white wires through firewall. Note: Extra caution should be taken not to damage the connector's pin. Seal with 3M Silicone sealant (picture 1)



Picture 1

Vehicle Disassembly

3. Remove driver side door scuff plate: Disengage with panel tool and remove (pic.2)

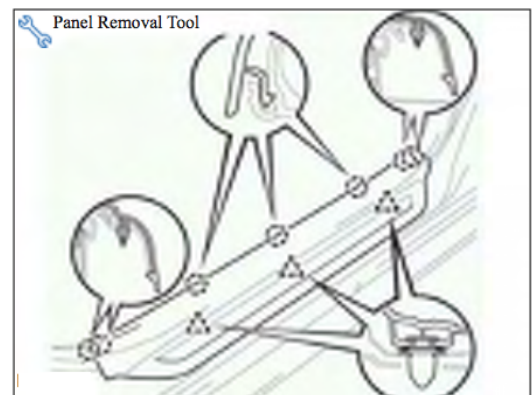

Picture 2

4. Remove the driver side cowl side trim. Unscrew the cowl side trim clip. Disengage two (2) clips and remove the cowl side trim (picture 3)

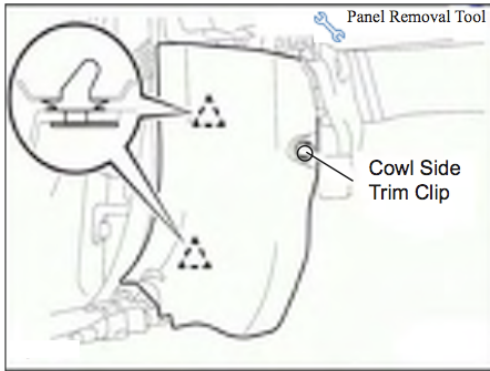

Picture 3

5. Using a pry tool, loosen the instrument cluster finish panel garnish located at the left of the steering wheel (picture 4~4B). Grip the instrument cluster finish panel garnish and pull it diagonally upward toward the rear to detach the 5 clips.

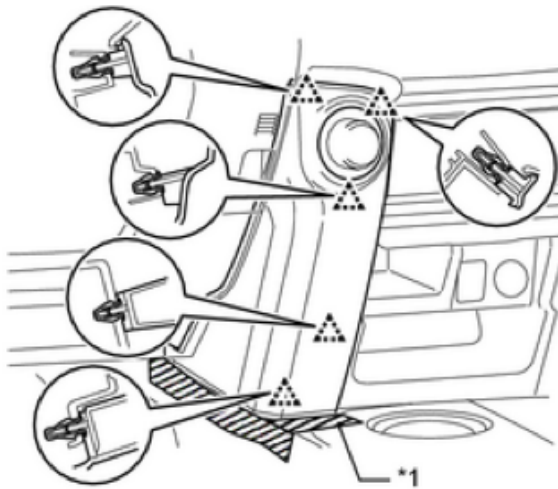

Picture 4A



Picture 4B

6. Remove the driver's side lower instrument panel finish sub-assembly:
 - Using a screwdriver, detach the 2 claws to open cover (picture 5). Remove 2 bolts (picture 5A) and detach the 13 clips and 2 guides. Then disconnect each connector and hood lock control cable assembly.

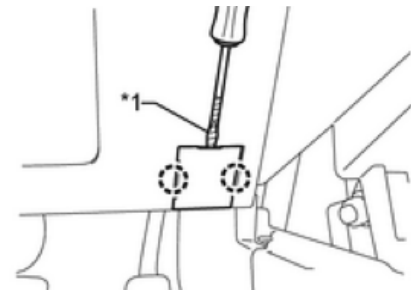

Picture 5

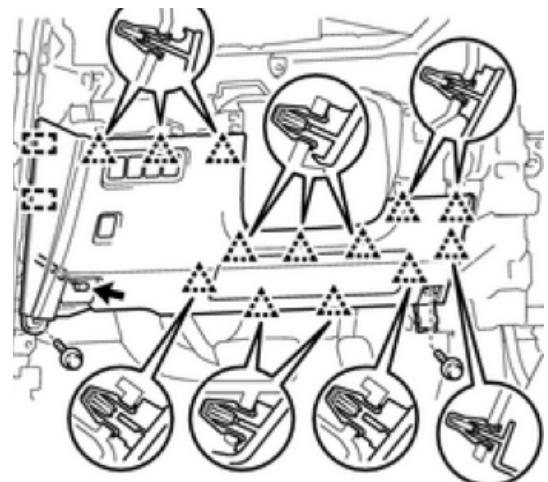

Picture 5A

- 7. Locate the wires that were pulled through the grommet in step 2. Route wire harness towards the left side of steering wheel. Use wire ties as needed
- 8. Push the pins of the DRL wire harness into the connector supplied in kit. The connector has a "+" and "-" marks. So connect the red wire into the "+" side and black wire into the "-" side. You may use the driver box as a guide: wire colors must be aligned with the wire colors of the driver box: black with black and red with red, etc (picture 6)

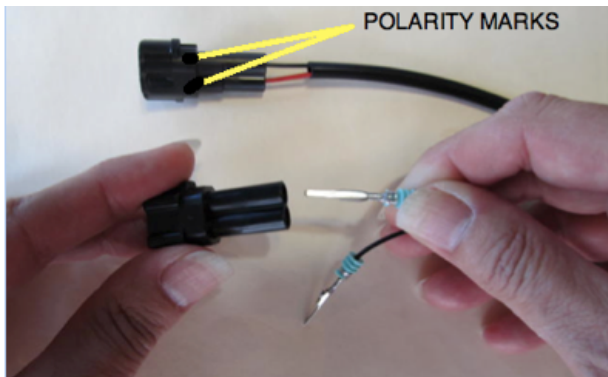

Picture 6

- 9. Connect the driver box to the wire harness (make sure wire colors are aligned).
- 10. Using a 14" wire tie, secure the driver box to factory harness, left of the steering wheel column (pic. 7).



Picture 7

- 11. Secure the black wire with a ring terminal from DRL harness to ground location behind kick panel (picture 8)



Picture 8

- 12. Install a black T-Tap to connector F4 pin 8, pink wire. Then connect the red wire from DRL harness to T-tap. Connector F4 is located at the back of mirror control switch. (pictures 9, 9A and 9B)

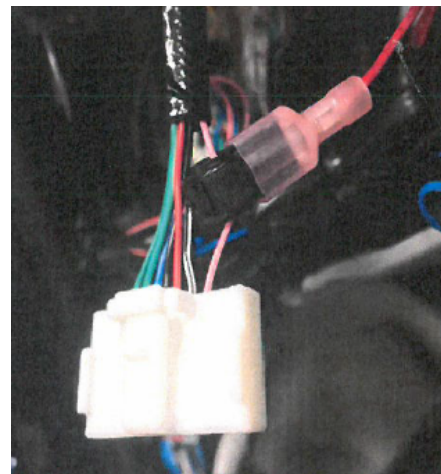

Picture 9: Mirror control switch

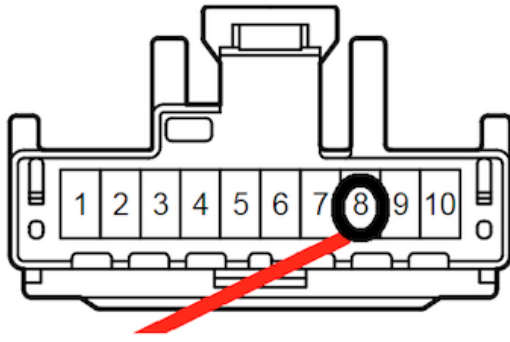

DRL's red wire to connector F4, pin 8, pink wire (7.5A Acc. Fuse)

Picture 9A:

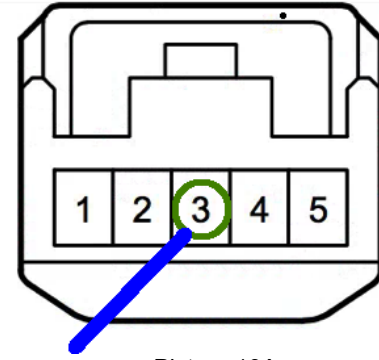

Picture 10A (7.5A Panel Fuse)

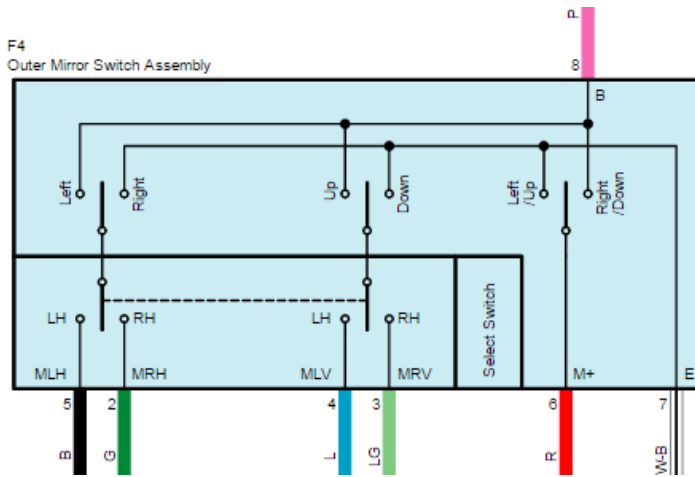

Picture 9B

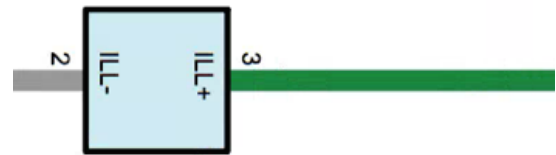

F3 Front Window Deicer Switch (Outer Mirror Heater Switch Assembly)

Picture 10B

13. Install a black T-Tap to connector F3, pin 3, green wire. Then connect the blue wire from DRL harness to t-tap. Connector F3 is located at the front window deicer dash switch (pictures 10, 10A and 10B).

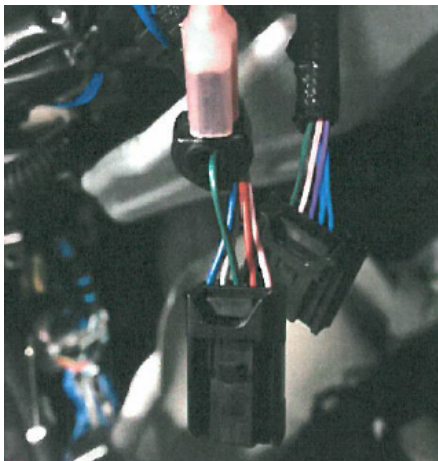

Picture 10

14. Secure any excess wire from t-taps, fuse and relay to main wire harness (picture 11). Make sure to leave enough lead on the switch green connector.

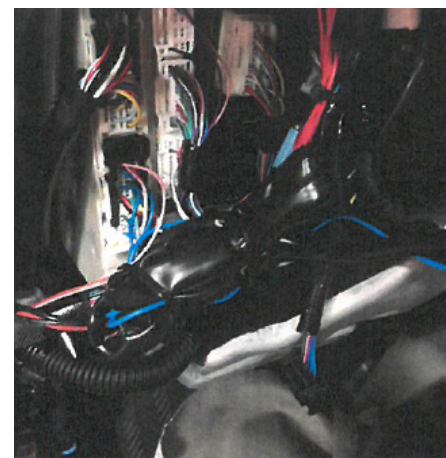

Picture 11

15. Route DRL switch connector through switch knockout. Use the switch knockout located at the left of the steering wheel, on the driver lower panel (picture 12).



Picture 12

- 16. Connect the switch wire harness to switch.
- 17. Reinstall panels and connectors

ENGINE COMPARTMENT

- 18. Remove the radiator grill protector by removing the push pins on top (picture 13)

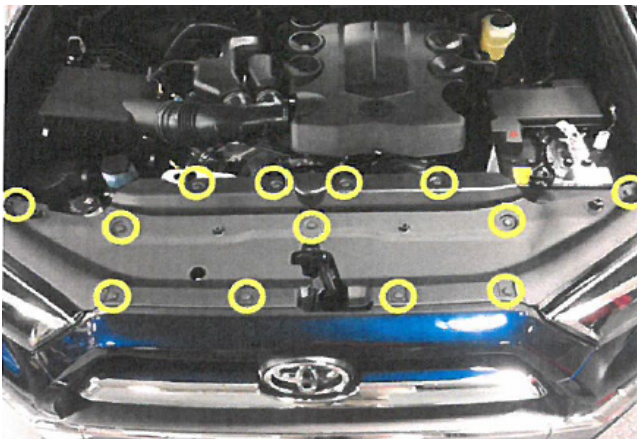

Picture 13

- 19. Run DRL's wire harness on the left side of vehicle, from the firewall towards the driver's side fog lamp area. Then route the passenger side end of the wire harness under hood latch safety. Use wire ties as shown (pictures 14~14B).



Picture 14



Picture 14A: on left side behind battery

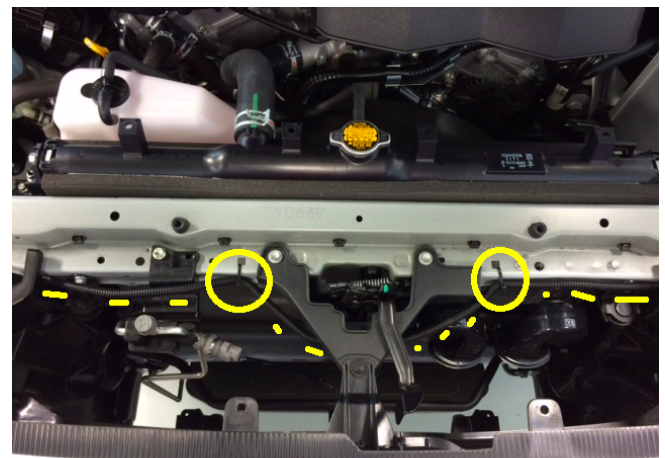

Picture 14B: Securing harness under the hood latch

- 20. Drop the driver side end of the wire harness towards the fog light area, and secure with wire ties (picture 15). Repeat this step on the passenger side.



Picture 15

- 21. From under the car, remove driver side lower splash shield: Using a pry tool to remove push pins (picture 16)



Picture 16



Picture 16A

- 22. Unplug driver side fog lamp (picture 17)

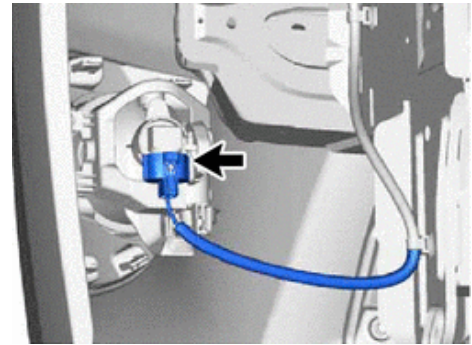

Picture 17

NOTE: Limited models, follow steps 23~27. Other models jump to step 28.

- 23. (Limited models): From above or below, remove the front bumper side moulding sub-assembly. Remove the 3 white retainer clips. Remove one screw, and detach 2 claws (picture 18). Optional use of protective tape.

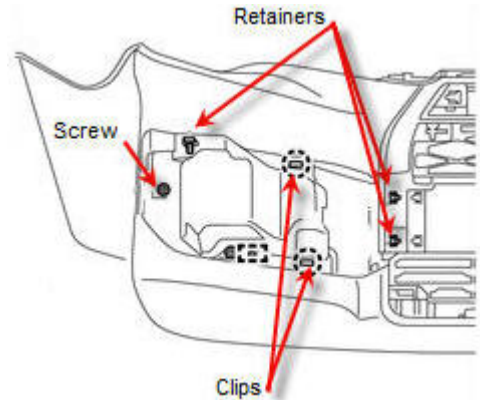

Picture 18



Picture 18A

24. *(Limited models)*: Remove driver side fog lamp from bumper side moulding, by 2 factory screws. Note: screws will be used on installation. Do not discard them (pic. 19).

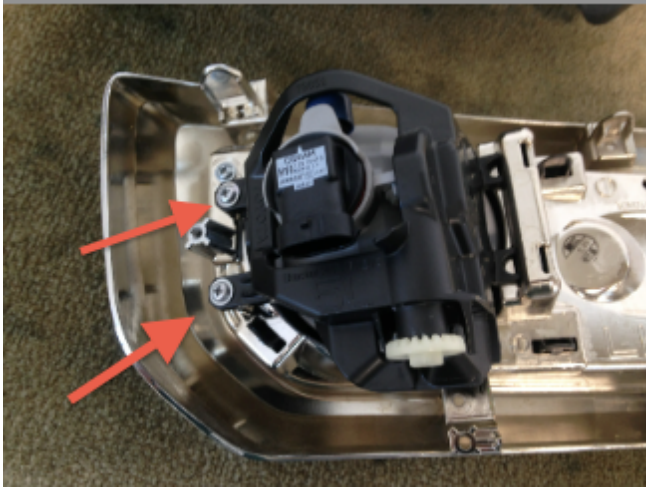

Picture 19

25. *(Limited models)*: Install 2in1 LH light into bumper side moulding.
26. *(Limited models)*: Reinstall bumper side moulding into bumper.
27. *(Limited models)*: Repeat steps 23~26 on passenger side.
28. Remove driver side fog lamp, by 2 factory screws. Note: screws will be used on installation. Do not discard them (pic. 20).

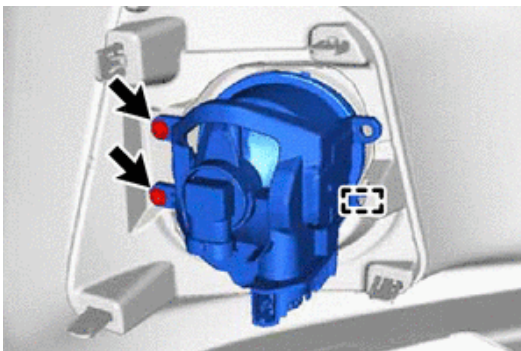

Picture 20

Note: If the fog light connector is pre-installed in the kit, proceed to step 32.

29. The factory fog light harness polarity is shown in picture 21. Pin 1 is negative. Pin2 is positive

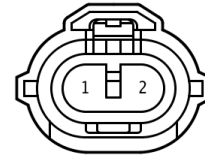

Picture 21: Factory Fog Light harness.
Pin 1: Negative
Pin 2: Positive



Picture 21A

30. Push the wires from LED fog light housing into the supplied connector, to match the polarity of the factory wire harness (pic. 22).



Picture 22: 2in1 Fog Light wire terminal.



Picture 22A: Showing Fog light terminal connected

31. Before connecting the LED Fog light, make sure that wires are aligned:
- LED Fog light red (+) with factory white (+)
 - LED Fog Light black (-) with factory white-black (-)

- 32. Insert one side of the 2in1 light housing into the plastic sleeve and secure other side with factory screws.

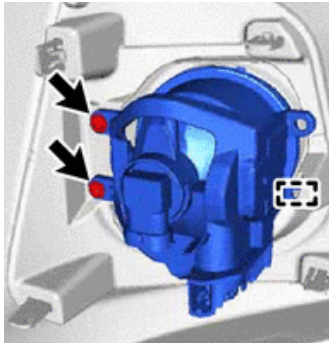

Picture 23

- 33. Plug the factory fog light connector into 2in1 fog light terminal (picture 24), and then connect the DRL harness to the 2 in 1 light DRL terminal.



Picture 24

- 34. Secure excess wire from DRL harness with wire ties.
- 35. Optional step: At the passenger side, partially remove the fender inner liner (picture 24).

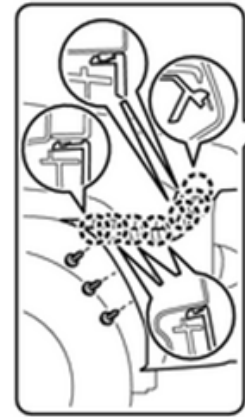

Picture 24

- 36. Repeat steps 28~35 on the passenger side. Prior to the removal of factory fog light, remove front bumper reinforcement stopper (picture 25). This will allow easier access to screws. Detach the 2 claws and guide to remove the reinforcement stopper. Using a pick tool, depress the two clips on the outside panel. Pull down and out gently.

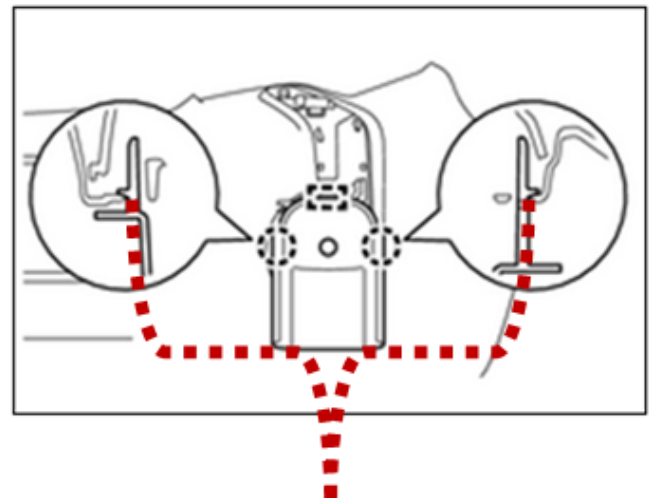

Picture 25

- 37. Reinstall lower splash shield.
- ⚠ 38. Reconnect negative battery terminal. Torque terminal to 48 in. lbs.

Note: Reinstall battery hold down bracket assembly, if removed. Torque both the J-Hook(s) Nut(s), and the 10mm bolt for the battery hold down bracket to 53 in. lbs.



Left: showing LED Fog Light "ON"
 Right: Showing DRL "on"

 **NOTE:** Use only hand tools to adjust the fog light aiming screw. DO NOT use automatic tools, as they will damage the fog light

Fog Light Aiming

Traditional fog lights are usually mounted in the front bumper about 10-24 inches from the ground. There are two important issues to address when installing fog lights: the first is to minimize the amount of return glare into the drivers eyes, and the other is to minimize the glare into oncoming eyes. Both of these issues must be accomplished while putting as much light as possible on the road.

These fog weather light aiming instructions are suggestions taken from common practice and the S.A.E. standard J583. Some modifications to these instructions may be necessary to minimize glare.

Visual aim is made with the top of the beam 4 inches below the lamp center at 25 feet with the lamp facing straight forward (see picture 26)

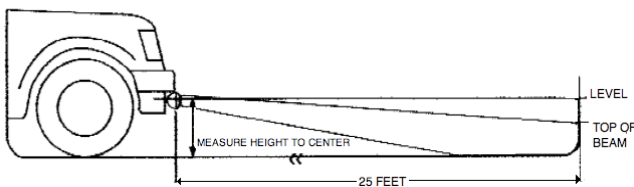

Picture 26

Checklist – these points MUST be checked to ensure quality installation

Check System for Operation

1. DRL will work at full power when ignition switch is ON. DRL will dim out to DOT specifications when lights are ON.
2. If DRL switch position is off, DRL will not work at any time.

Check

Accessory Functions Checks

- DRL function.....
- Fog Lights function.....
- All Panels snapped into place.....
- Fog Lights.....
- Battery Terminal.....
- Operation Guide.....

Vehicle Function checks

- Check functions all switch functions

Look For:

-
-
- Loose panels and switches
- Visually confirm lights are straightforward
- Re-torque battery terminals to 48 in-lb
- Place DRL operation guide inside glove box.

Block Diagram

LED DRL + LED Fog Light 2in1

Ver. 2.21.2015

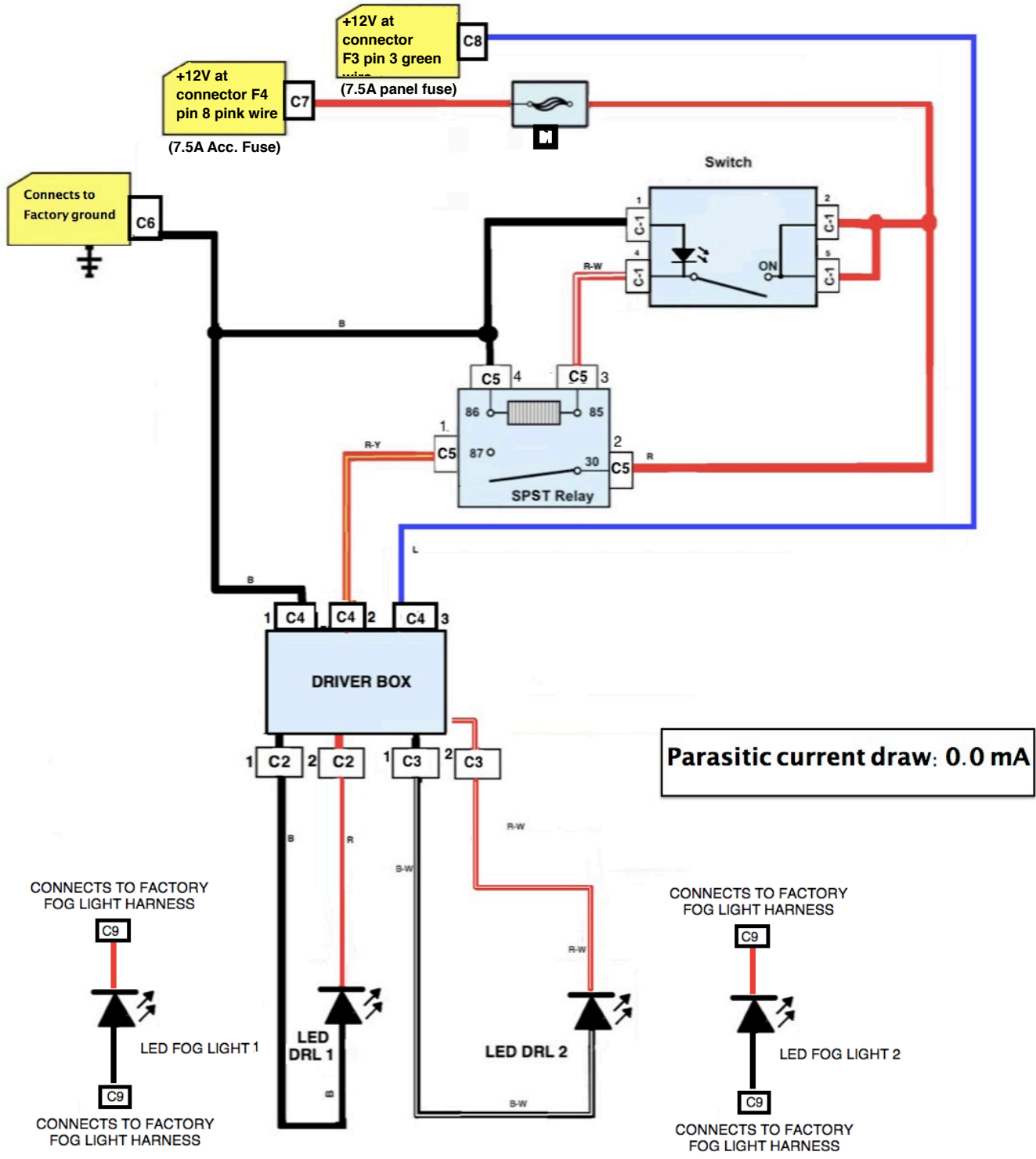

Pinout test

Connector C-1

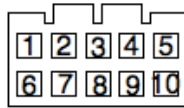

Pin	Wire Color	Test Reference	Proper Operation
1	Black	Pin 1 to Ground	Approximately 0 VDC
2	Red	Pin 2 to Ground	Approximately 0 VDC ignition switch is OFF +12 VDC when ignition switch is ON
4	Red-White	Pin 4 to Ground	Approximately 0 VDC ignition switch is OFF Approximately 0 VDC ignition switch is ON, DRL switch is OFF +12 VDC when ignition switch is ON and DRL switch is ON
5	Red	Pin 5 to Ground	Approximately 0 VDC ignition switch is OFF +12 VDC when ignition switch is ON

Connector C-2, C-3

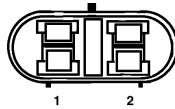

Pin	Wire Color	Test Reference	Proper Operation
1	Red or Red-White	Pin 1 to Ground	Aproximately 0 VDC when igntion switch is OFF Aproximately 0 VDC when ignition switch is ON, DRL switch is OFF Aproximately +18 to +24 VDC when ignition switch is ON, DRL switch is ON
2	Black or Black-White	Pin 2 to Ground	Aproximately 0 VDC

Connector C-4

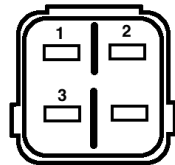

Pin	Wire Color	Test Reference	Proper Operation
1	Black	Pin 1 to Ground	Aproximately 0 VDC
2	Red-Yellow	Pin 2 to Ground	Approximately 0 VDC ignition switch is OFF Approximately 0 VDC ignition switch is ON, DRL switch is OFF +12 VDC when ignition switch is ON and DRL switch is ON
3	Blue	Pin 3 to Ground	Aproximately 0 VDC dash panel lights are OFF +12 VDC when dash panel lights are ON

Connector C-5

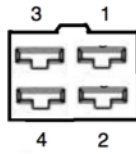

FEMALE TERMINAL VIEW

Pin	Wire Color	Test Reference	Proper Operation
1	Red-Yellow	Pin 1 to Ground	Approximately 0 VDC ignition switch is OFF Approximately 0 VDC ignition switch is ON, DRL switch is OFF +12 VDC when ignition switch is ON and DRL switch is ON
2	Red	Pin 2 to Ground	Approximately 0 VDC ignition switch is OFF +12 VDC when ignition switch is ON
3	Red-White	Pin 3 to Ground	Approximately 0 VDC ignition switch is OFF Approximately 0 VDC ignition switch is ON, DRL switch is OFF +12 VDC when ignition switch is ON and DRL switch is ON
4	Black	Pin 3 to Ground	Aproximately 0 VDC

Connector C-6



Pin	Wire Color	Test Reference	Proper Operation
1	Black	Pin 1 to Ground	Aproximately 0 VDC

Connector C-7



Pin	Wire Color	Test Reference	Proper Operation
1	Red	Pin 1 to Ground	Aproximately 0 VDC when ignition switch is OFF +12 VDC when ignition switch is ON

Connector C-8



Pin	Wire Color	Test Reference	Proper Operation
1	Blue	Pin 1 to Ground	Aproximately 0 VDC dash panel lights are OFF +12 VDC when dash panel lights are ON

Connector C-9

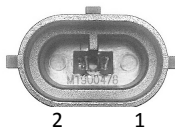

Pin	Wire Color	Test Reference	Proper Operation
1	Black	Pin 1 to Ground	Aproximately 0 VDC
2	Red	Pin 2 to Ground	Approximately 12 VDC headlamp switch is ON and FOG Light switch is ON +0 VDC all other times