

Toyota Prius

2008-

Interior Light Upgrade

Part Number : 00016-00065

Accessory Code: IL1



Kit Contents

Item #	Quantity Req'd.	Description
1	2	9" & 13" Light Rod
2	1	Wire harness
3	1	Hardware Kit
4	2	White Light Engines
5	1	Switch Kit
6	2	Amber cup holder kits
7	1	Customer Information card
8	1	Die Cut Adhesive
9	1	"Y" Adapter

Hardware Bag Contents

Item #	Quantity Req'd.	Description
1	4	Catamount
2	4	8-32 x .375 screw
3	4	"U" nut
4	4	Wire tie .187
5	4	Wire tie .0625
6	6	foam pads
7	2	T-Taps

Switch Bag Contents

Item #	Quantity Req'd.	Description
1	1	Switch
2	1	End Cap, Black
3	1	Illumination Nameplate
4	1	Installation tool
5	1	Bezel
6	1	Black spacer

Recommended tools

Safety Tools	
Vehicle protection	
Safety glasses	
Special Tools	
Installation Tools	
Phillips screwdriver	#2
Torque wrench	53"lbs
Nylon Removal Tool	
Pliers	
Diagonal cutter	or wire tie tool
Stubby screwdriver	#2 Phillips
Drill motor	
Scissors	
1/2" & 3/8" Drill bit.	UniBit or step drill rec.
1/8" Drill bit	
Scribe or Center punch	
Masking tape	
Panel clip tool	
9/32" Drill bit	
Wiping cloth Non-scratch	
Special Chemicals	
Window cleaner	

Color Applicability/Trim Level

Accessory Color										

General Applicability

All models of Prius

Recommended Sequence of Application

Item #	Accessory	
1 *	Overlay	Apply any overlay first
2		
3		

*Mandatory

Legend

STOP: Damage to the vehicle may occur. Do not proceed until process has been complied with.

OPERATOR SAFETY: Use caution to avoid risk of injury.

CAUTION: A process that must be carefully observed in order to reduce the risk of damage to the accessory/vehicle and to ensure a quality installation.

TOOLS & EQUIPMENT: Used in Figures calls out the specific tools and equipment recommended for this process.

REVISION MARK: This mark highlights a change in installation with respect to previous issue.

SAFETY TORQUE: This mark indicates that torque is related to safety.



SPECIAL NOTE: Installation Sequences

After **TMS** and **Safety** mandated preparatory steps have been taken, the installation sequence is the suggested method for completing the accessory installation. In some instances the suggested sequence is written for one associate to install and in others the sequence is given as part of a team accessory installation. Unless otherwise stated in the document, the associates may perform the installation steps in any order to make the installation as efficient as possible while maintaining consistent quality.

A. Check Kit Contents

1. Check kit for content and damage. (Fig. A1)

B. Vehicle Preparation

-  1. Remove battery negative terminal.
-  2. Apply protective covering to vehicle

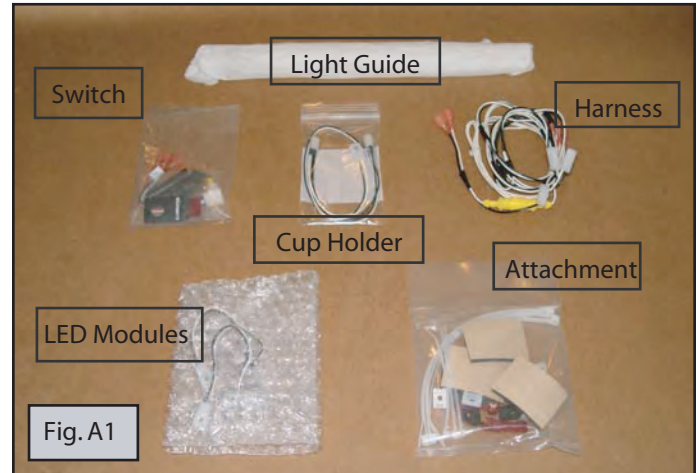

C. Remove center console

1. Remove forward cup-holder assembly.
 - i. Use panel safe tool.
 - ii. Carefully pry around cup-holder assembly. (Fig. C1)
 - iii. Pull cup-holder assembly forward. (Fig. C2)
 - iv. Place front cup-holder aside.
2. Remove center mount bolts
 - i. Remove insert. (Fig. C3)
 - ii. Remove (2) 10mm bolts. (Fig. C4)
3. Remove (2) screws on forward lower edge of console. (Fig. C5)
4. Remove console from car.

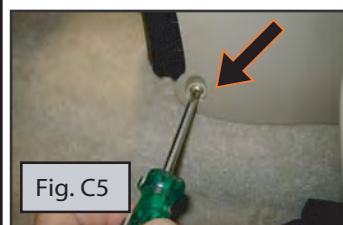
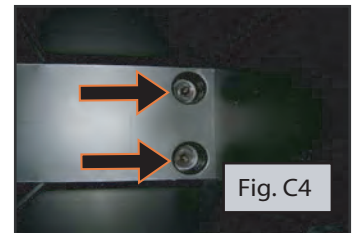
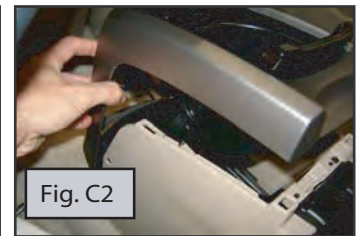
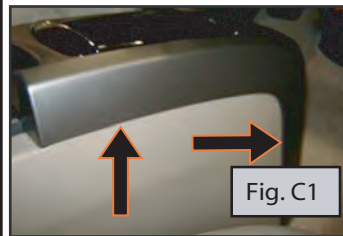

Section II - Installation Procedures

D. Install Storage Box Lights.

1. Drill holes for LEDs
 - i. Cut out "Prius storage box" template.
 - ii. Align template inside storage box as show. (Fig. D1)
 - iii. Use a punch/scribe to mark the center of the hole to be drilled.
 - iv. Drill pilot holes with 1/8" drill bit.
 - v. Drill the lamp hole with a 9/32" drill bit.
 - vi. De-burr holes with de-burring tool.
2. Insert lens from inside storage box.
3. From the back of the storage box, install the LED's onto the lenses. Press firmly while holding the Lens from the inside. (Fig. D2)
4. Route wires under box and Secure with foam pad. (Fig. D3)

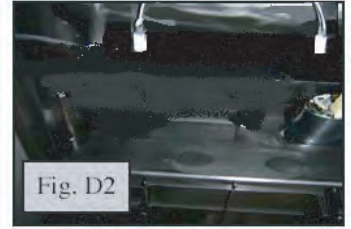

E. Install power Switch

1. Remove lower center dash cover.
 - i. Use “*spade*” tool. Remove plastic insert. (Fig. E1)
 - ii. Pull center dash cover firmly towards rear of vehicle. Disconnect power lead.(Fig. E2)
2. Drill hole for switch.
 - i. Cut out enclosed paper “Prius Switch” template. (Fig. E3)
 - ii. Place template so hole drilled will be oriented as pictured. (Fig. E3)
 - iii. Place template in area indicated. Use a punch or scribe to mark center of the hole to be drilled. (Fig. E4)
 - iv. Using a 1/2” drill bit (Unibit or step drill is highly recommended), drill the switch hole.
3. Clean console surface to remove grease and wax.
 - i. Wipe the application area clean with alcohol and a clean no-scratch cloth
 - ii. Dry the installation area using a clean, dry, lint free cloth.
4. Insert switch bezel into switch plate. (Fig. E5)
5. Using the pull-tab, remove the tape liner from the back of the switch plate. (Fig. E6)
 - i. Avoid finger contact with the adhesive surface.
 - ii. Align the printing “ILLUMINATION” as shown. (Fig. E7)
 - iii. Install switch plate/bezel into the previously drilled 1/2” hole.
 - iv. Once aligned, press down firmly to adhere tape.



Fig. E1



Fig. E2

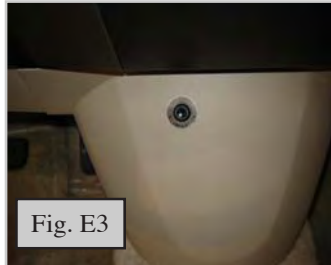

Fig. E3



Fig. E4



Fig. E5

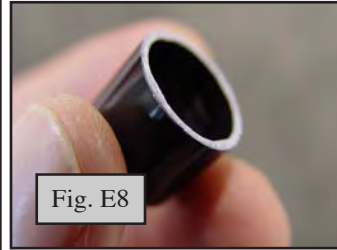

Fig. E6



Fig. E7

6. Install Sleeve to bezel.
 - i. The “white” ink end of the sleeve must be installed against the console. (Fig. E8)
 - ii. Using switch tool turn switch bezel clockwise to tighten.
 - iii. Be careful not to over tighten as this will “over ride” the threads on the switch. If this happens simply retighten being careful not to over tighten.
 - iv. Push button into bezel pressing to engage.
7. Place aside until main harness is installed.



F. Install Harness

1. Lay out harness as shown and identify connectors. (Fig. F1)
2. Thread Cupholder lead under the carpet towards the center console storage box. (Fig. F2)
2. Bulk of harness will reside under lower center dash cover.
3. Locate power.
 - i. Locate auxiliary power connector towards upper right of center dash cover. (Fig. F3)
 - ii. Install T-taps in staggered fashion. (Fig. F4)
4. Attach harness to power. (Fig. F4)
 - i. Black wire on harness to connector P3 wt/ blk, pin1.
 - ii. White wire on harness to connector P3 white, pin 2.
5. Connect switch to main harness.
 - i. Connect switch leads, make sure letters match respective connection. (Fig. F5)
6. Reinstall center console making sure that the LED module leads are pointed forward. (Fig. F1)
 - i. Slide console forward.
 - ii. Reinstall Plastic “button”. (Fig. F6)

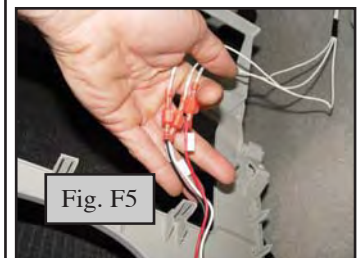
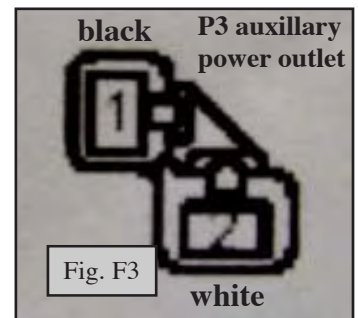
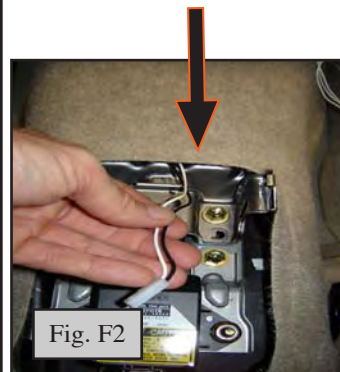
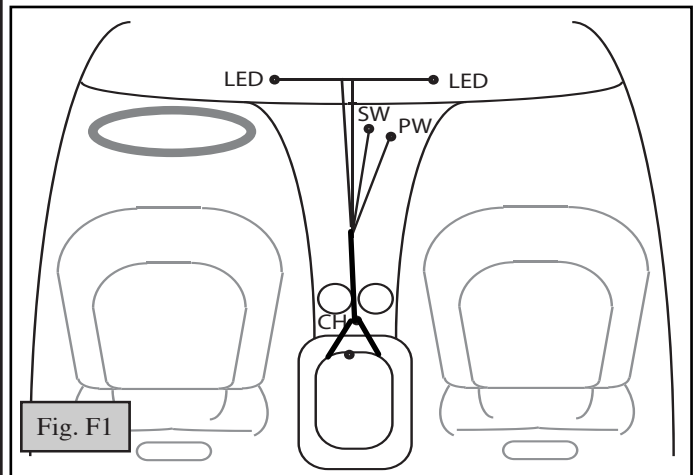

G. Install Light Guide

1. Install drivers side light guide.

Note: Shorter rod goes on passenger side.

- i. Attach "U" nut and catamount to lower edge of air duct as shown. (Fig. G1)
- ii. Make sure catamount is open downwards facing floor.

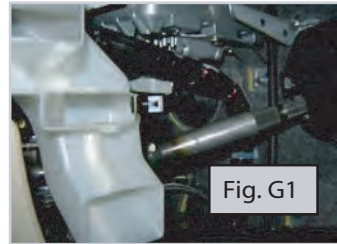

2. Attach LED Module to Light Guide.

3. Install the light guide in the plastic mount using 1/4" wire ties.

- i. Feed the wire ties into the plastic mount and hole.
- ii. Insert the light guide assemblies into the mounts. The light guide assemblies should be orientated with the white "reflector" at the top, the LED modules positioned toward the center of the vehicle. (Fig.G2)
- iii. Thread second 1/4" wire tie through slot in knee bolster as shown. (Fig. G3)

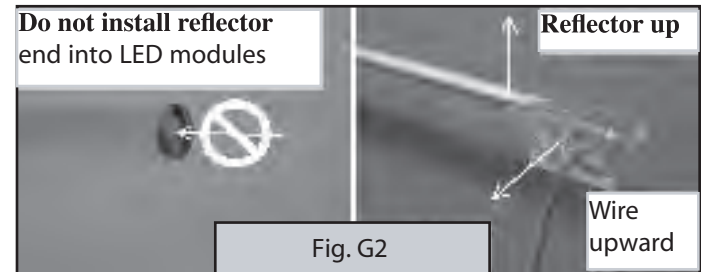

iv. Finished assembly installation as shown. (G4)



4. Install passenger side light guide.

- i. Depress tabs on leading edge of shield and remove. (Fig. G5)
- ii. Place template as shown, punch mark holes and drill with 3/8 drill bit. (Fig. G6)
- ii. From top of shield thread cable ties.
- iii. Excess cable will extend through shield as shown. (Fig.G7)

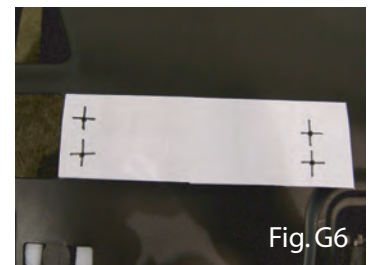

5. Install the light guide into the cable ties.

- i. Insert the light guide assembly into the cable ties. The light guide assemblies should be orientated with the white "reflector" at the top, the LED modules positioned toward the center of the vehicle. (Fig. G8)
- ii. Fully tighten the wire ties and cut off excess.



iii. Reinstall shield. (Fig. g9)

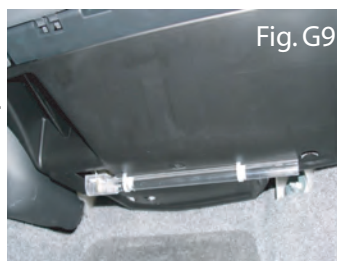

M. Post Installation

1. Reinstall interior.
2. Re-attach negative battery terminal, torque to 53 inch pounds.
3. Clean Light Guides with window cleaner and a non-scratch cloth.
4. Cycle test the system with the key in the ACC or ON position. The cycle may start from any step below but should cycle in this order.
 - i. All lights off.
 - ii. Console Storage Bin area lit .
 - iii. All lights on.
 - iv. Under dash light on only.
 - v. Back to step “i”.
5. The switch should be cycled to step “i” (all lights off) for shipment.
6. Place information card in glove box.

VEHICLE FUNCTION CHECK

AFTER ALL PANELS, COVERS,
AND COMPONENTS HAVE BEEN
REINSTALLED, THAT WERE REMOVED,
TEST THOROUGHLY, ALL MECHANICAL
AND ELECTRICAL COMPONENTS
DISCONNECTED AND OR REMOVED
FROM THE VEHICLE DURING THE
INSTALLATION OF THIS ACCESSORY.

Section III Functional verification

Check:

Single Unoperational Module

No Operational Modules

Look for:

Full engagement of affected LED module to LED wire harness pigtail connector.

Light guide inserted incorrectly (wrong end)

Full engagement of all LED module to LED wire harness pigtail connectors.

Power connection.

Ground connection

Switch connections

Blown light kit fuse. (2 amp located under center console)

Blown shift console illumination fuse (see vehicle owners manual for amperage and location.)

Prius Templates

Switch Template

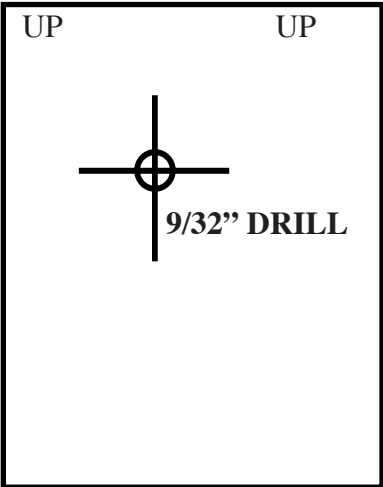

STORAGE BOX TEMPLATE

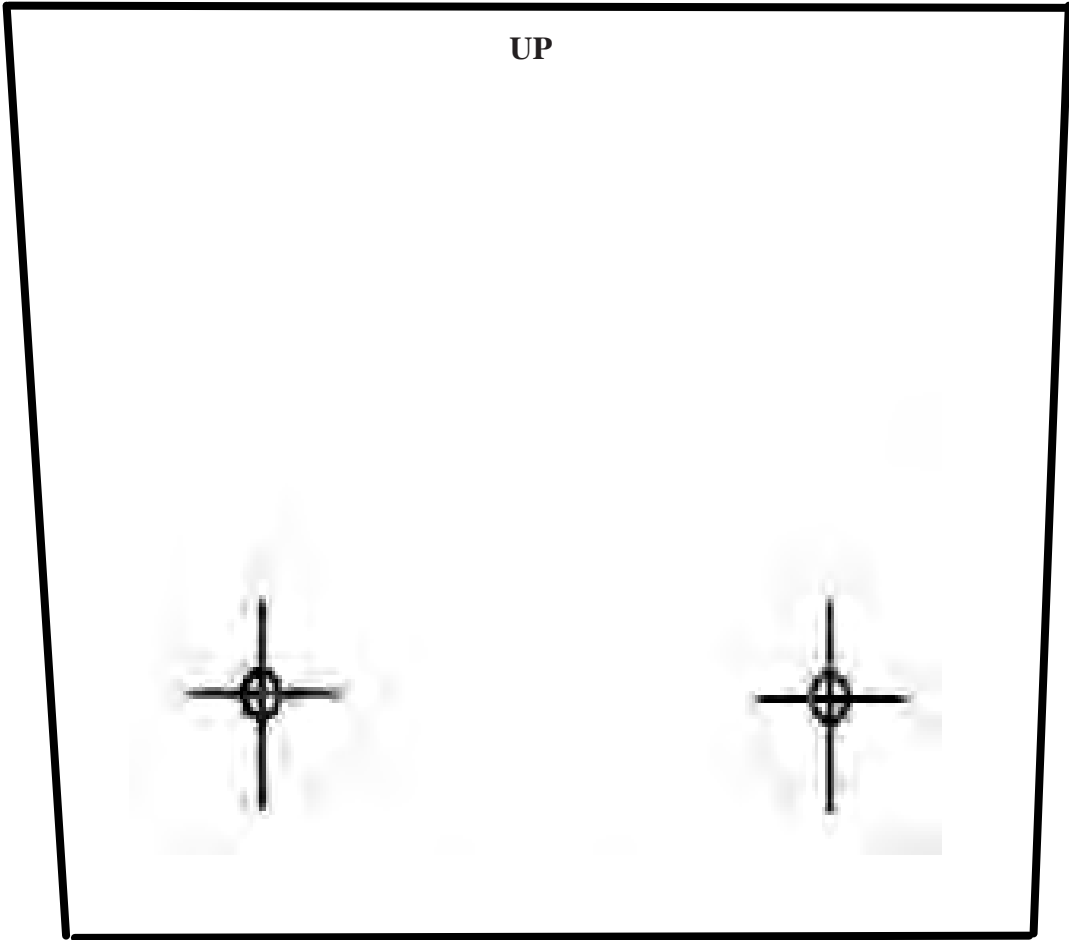

Prius Template

Passenger Side Guide Light

