



**A. Check Kit Contents**

- ➔ 1. Check kit for content and damage. (Fig. A1)

**B. Vehicle Preparation**

- STOP 1. Remove battery negative terminal.  
STOP 2. Apply protective covering to vehicle

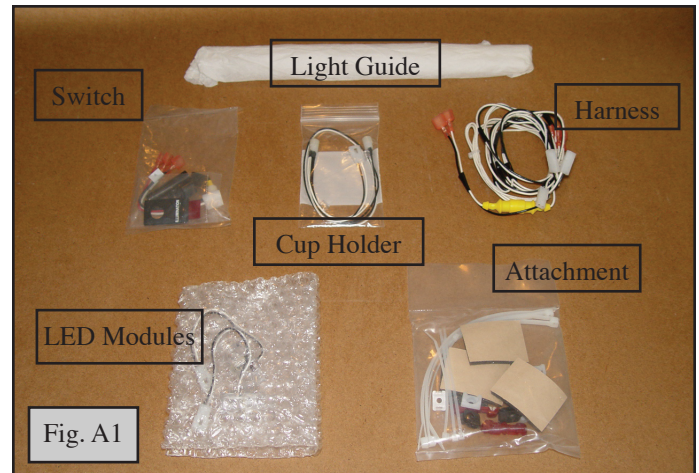

**C. Remove center console**

1. Remove forward cup-holder assembly.
  - i. Use panel safe tool.
  - ii. Carefully pry around cup-holder assembly. (Fig. C1)
  - iii. Pull cup-holder assembly forward. (Fig. C2)
  - iv. Place front cup-holder aside.
2. Remove center mount bolts
  - i. Remove insert. (Fig. C3)
  - ii. Remove (2) 10mm bolts. (Fig. C4)
3. Remove (2) screws on forward lower edge of console. (Fig. C5)
4. Remove Rear cup-holder assembly.
  - i. Use panel safe tool.
  - ii. Carefully pry around cup-holder assembly. (Fig. C6)
  - iii. Pull cup-holder assembly towards rear. (Fig. C7)
  - iv. Disconnect power leads. (Fig. C8)
  - v. Place rear cup-holder aside.

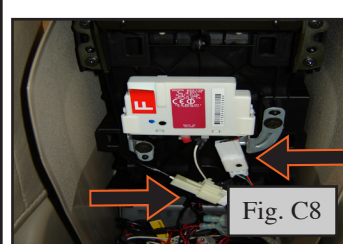
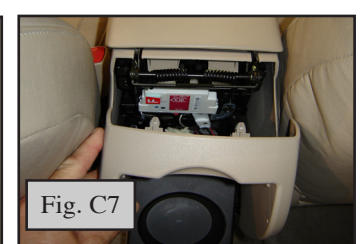
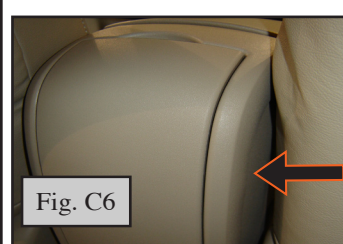
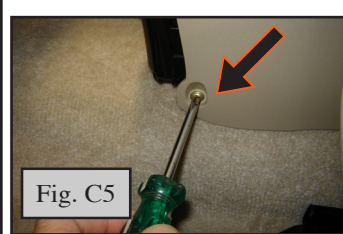
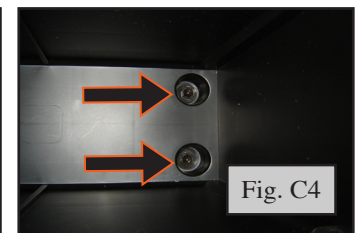
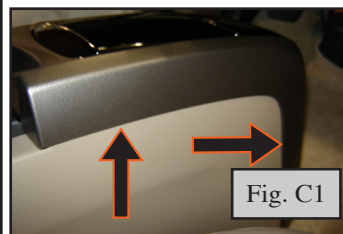

### D. Install Storage box Lights

1. Install rear storage box light.
  - i. Drill hole using existing round casting as shown, indicated in photo by round circle. (Fig. D1)
  - ii. Use a punch/scribe to mark the center of the hole to be drilled.
  - iii. Drill pilot holes with 1/8" drill bit.
  - iv. Drill the lamp hole with a 9/32" drill bit (Fig. D2).
  - v. De-burr holes with de-burring tool.
2. Install forward storage box light.
  - i. Cut out template "forward storage box template" Align with rib in casting. (Fig. D3)
  - ii. Use a punch/scribe to mark the center of the hole to be drilled.
  - iii. Drill pilot holes with 1/8" drill bit.
  - iv. Drill the lamp hole with a 9/32" drill bit.
  - v. De-burr holes with de-burring tool.
3. Insert lenses from inside storage box.
4. From outside of storage box, install the LED's onto the lenses. Press firmly while holding the Lens from the inside. (Fig. D4)
5. Route wires down and forward and secure with a foam pad, secure any excess with foam pad. (Fig. D5)
6. Place storage box assembly aside.

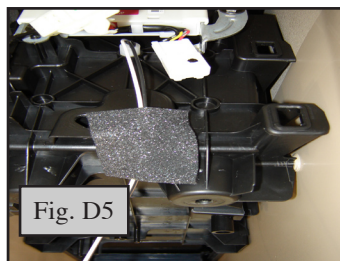
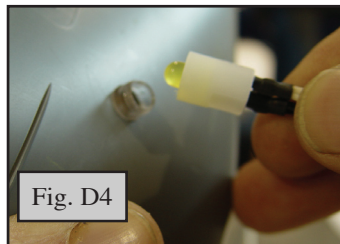
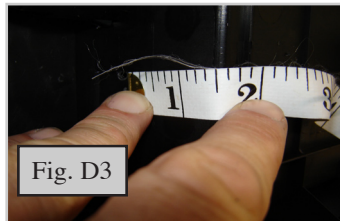
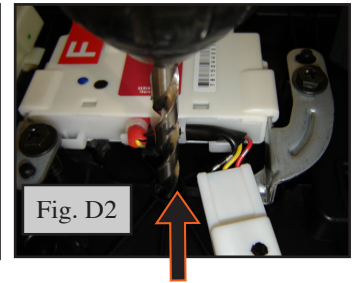
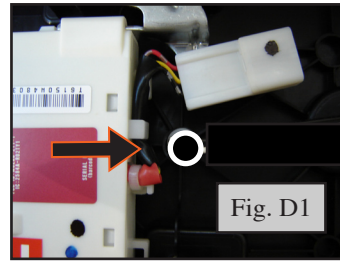

### E. Install power Switch

1. Remove lower center dash cover.
  - i. Use “*panel clip*” tool. Remove plastic insert. (Fig. E1)
  - ii. Pull center dash cover firmly towards rear of vehicle. (Fig. E2)
2. Drill hole for switch.
  - i. Cut out enclosed paper “Prius Switch” template.
  - ii. Place template so hole drilled will be oriented as pictured. (Fig. E3)
  - iii. Place template in area indicated. Use a punch or scribe to mark center of the hole to be drilled. (Fig. E4)
  - iv. Using a 1/2” drill bit (Unibit or step drill is highly recommended), drill the switch hole.
3. Clean console surface to remove grease and wax.
  - i. Wipe the application area clean with alcohol and a clean no-scratch cloth
  - ii. Dry the installation area using a clean, dry, lint free cloth.
4. Insert switch bezel into switch plate. (Fig. E5)
5. Using the pull-tab, remove the tape liner from the back of the switch plate. (Fig. E6)
  - i. Avoid finger contact with the adhesive surface.
  - ii. Align the printing “ILLUMINATION” as shown. (Fig. E7)
  - iii. Install switch plate/bezel into the previously drilled 1/2” hole.
  - iv. Once aligned, press down firmly to adhere tape.

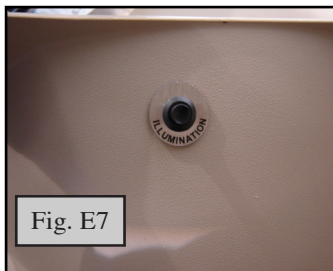
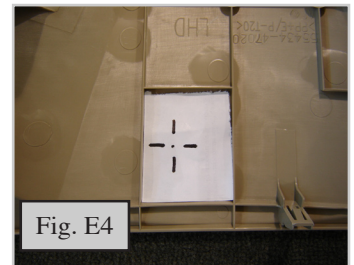
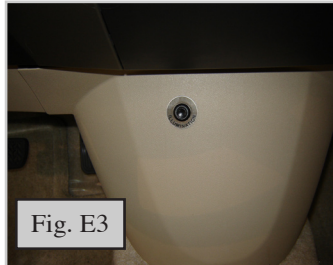

6. Install Sleeve to bezel.
  - i. The “white” ink end of the sleeve must be installed against the console. (Fig. E8)
  - ii. Using switch tool turn switch bezel clockwise to tighten.
  - iii. Be careful not to over tighten as this will “over ride” the threads on the switch. If this happens simply retighten being careful not to over tighten.
  - iv. Push button into bezel pressing to engage.
7. Place aside until main harness is installed.

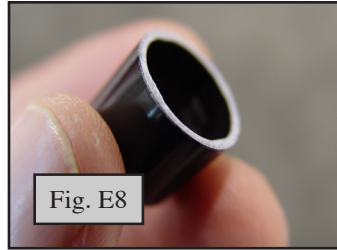

**F. Install Harness**

1. Lay out harness as shown and identify connectors. (Fig. F1)
2. Thread Cupholder lead under the carpet towards the center console storage box. (Fig. F2)
2. Bulk of harness will reside under lower center dash cover.
3. Locate power.
  - i. Locate auxiliary power connector towards upper right of center dash cover. (Fig. F3)
  - ii. Install T-taps in staggered fashion. (Fig. F4)
4. Attach harness to power. (Fig. F4)
  - i. Black wire on harness to connector P3 wt/ blk, pin1.
  - ii. White wire on harness to connector P3 white, pin 2.
5. Connect switch to main harness.
  - i. Connect switch leads, make sure letters match respective connection. (Fig. F5)
6. Reinstall center console making sure that the LED module leads are pointed forward. (Fig. F1)
  - i. Slide console forward.
  - ii. Reinstall Plastic "button". (Fig. F6)

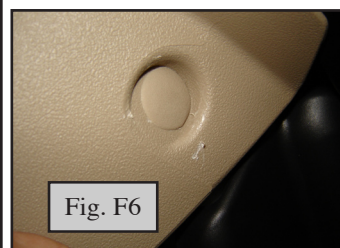
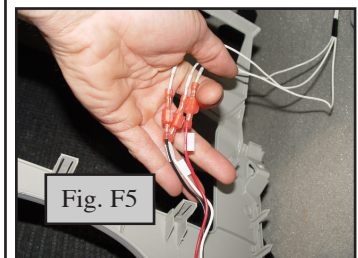
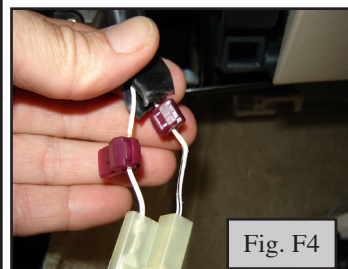
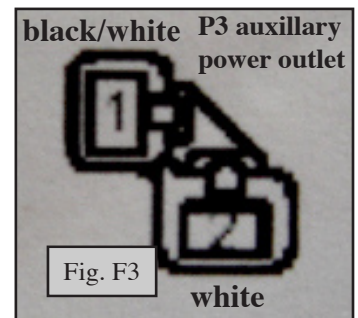
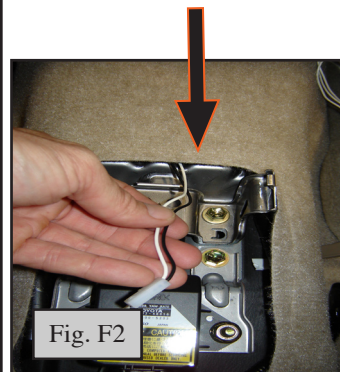
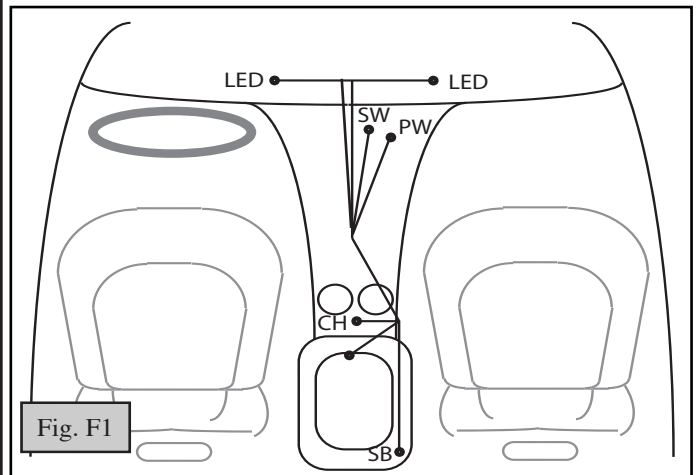

**G. Install Light Guide**

1. Install drivers side light guide.
  - i. Attach “U” nut and catamount to lower edge of air duct as shown. (Fig. G1)
  - ii. Make sure catamount is open downwards facing floor.
2. Attach LED Module to Light Guide.
3. Install the light guide in the plastic mount using 1/4” wire ties.
  - i. Feed the wire ties into the plastic mount and hole.
  - ii. Insert the light guide assemblies into the mounts. The light guide assemblies should be orientated with the white “reflector” at the top, the LED modules positioned toward the center of the vehicle. (Fig.G2)
  - iii. Thread second 1/4” wire tie through slot in knee bolster as shown. (Fig. G3)
  - iv. Finished assembly installation as shown. (G4)
4. Install passenger side light guide.
  - i. Depress tabs on leading edge of shield and remove. (Fig. G5)
  - ii. Install Catamount to opening on shield as shown. (Fig. G6)
  - iii. From top of shield thread cable ties as shown. (Fig. G6)
  - iv. Excess cable will extend through shield as shown. (Fig.G7)
5. Install the light guide into the cable ties.
  - i. Insert the light guide assembly into the cable ties. The light guide assemblies should be orientated with the white “reflector” at the top, the LED modules positioned toward the center of the vehicle. (Fig. G8)
  - ii. Fully tighten the wire ties and cut off excess.
  - iii. Reinstall shield. (Fig. g9)

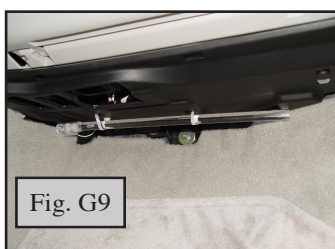
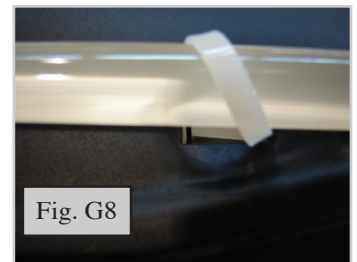
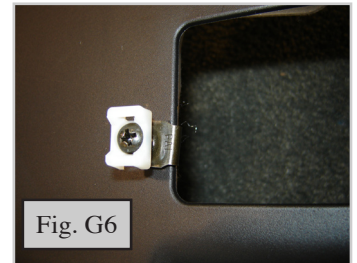
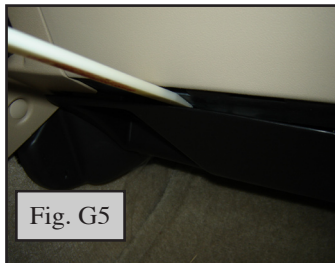
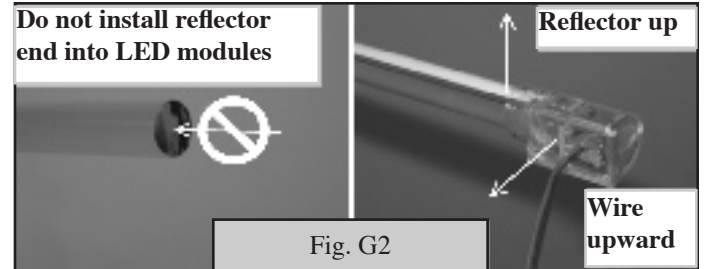
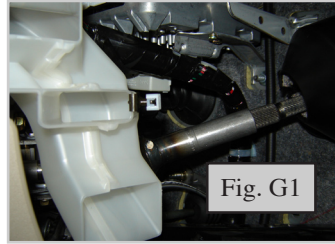

**M. Post Installation**

1. Reinstall interior.
2. Re-attach negative battery terminal, torque to 36 inch pounds.
3. Clean Light Guides with window cleaner and a non-scratch cloth.
4. Cycle test the system with the key in the ACC or ON position. The cycle may start from any step below but should cycle in this order.
  - i. All lights off.
  - ii. Cup holder lights on only.
  - iii. All lights on.
  - iv. Interior Light on only.
  - v. Back to step “i”.
5. The switch should be cycled to step “i” (all lights off) for shipment.
6. Place information card in glove box.

Section III Functional verification

Check:

\_\_\_\_\_

Single Unoperational Module

No Operational Modules

Look for:

\_\_\_\_\_

Full engagement of affected LED module to LED wire harness pigtail connector.

Light guide inserted incorrectly (wrong end)

Full engagement of all LED module to LED wire harness pigtail connectors.

Power connection.

Ground connection

Switch connections

Blown light kit fuse. (2 amp located under center console)

Blown shift console illumination fuse (see vehicle owners manual for amperage and location.)

**VEHICLE FUNCTION CHECK**

AFTER ALL PANELS, COVERS, AND COMPONENTS HAVE BEEN REINSTALLED, THAT WERE REMOVED, TEST THOROUGHLY, ALL MECHANICAL AND ELECTRICAL COMPONENTS DISCONNECTED AND OR REMOVED FROM THE VEHICLE DURING THE INSTALLATION OF THIS ACCESSORY.

# Prius Templates

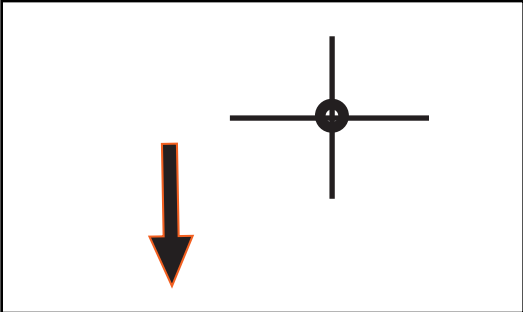

STORAGE BOX TEMPLATE

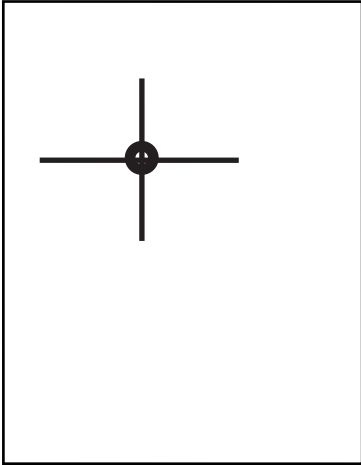

STORAGE BOX TEMPLATE



Two inches